

FLOWING EXPERTISE

FEBRUARY 2023



PLUMBING AND  
HYDRONICS  
CATALOG



# FLOWING EXPERTISE

With our heating and plumbing solutions, we have been redesigning the comfort of the spaces we live and work in for over 60 years. This is thanks to the flow of expertise, technology, experience and innovations that we have acquired over the years by constantly exchanging ideas with our customers and suppliers. A flow that pushes boundaries, allowing us to constantly set the benchmark. A flow that allows us to always look one step ahead into the future.



## FLOW OF LIFE

A unique way of flowing. It is **continuous change**, a high degree of reliability in our work, and the ongoing pursuit of total quality, which is the result of small daily actions.



## FUTURE

Innovation aimed at creating **new forms of comfort** for spaces, which motivates us to continue to grow and improve.



## SUSTAINABILITY

Our focus on preserving **environmental, social and economic well-being** so that it can be passed on to future generations through our products and processes.



## TECHNOLOGY

Our ability to do research, invest in processes and develop **state-of-the-art solutions** in an ever-evolving world of expertise.



## MADE IN CALEFFI

A uniqueness consisting of many details, which is what we are known for worldwide. True **“Made in Italy”** quality, the hallmark of our company.



SECTION	PAGES	
1	11	HYDRAULIC SEPARATORS
2	17	AIR AND DIRT SEPARATORS AND AIR VENTS
3	31	THERMOSTATIC RADIATOR VALVES
4	37	ZONE VALVES, ZONE CONTROLS AND COIL KITS
5	47	DISTRIBUTION MANIFOLDS AND TEMPERATURE MIXING STATIONS
6A	55	MIXING VALVES FOR PLUMBING AND HYDRONICS
6B	67	BALANCING VALVES FOR PLUMBING AND HYDRONICS
6C	83	PRVS, BACKFLOW PREVENTERS AND VACUUM RELIEF VALVES
6D	95	PLUMBING MISCELLANEOUS COMPONENTS
7	103	FILLING UNITS AND BOILER TRIM KITS
8	109	FITTINGS AND MISCELLANEOUS COMPONENTS
9	119	RENEWABLES, SOLAR AND BIOMASS DEVICES
10	125	ENERGY METERS
11	130	INDEX

# Hydronics Product Selector

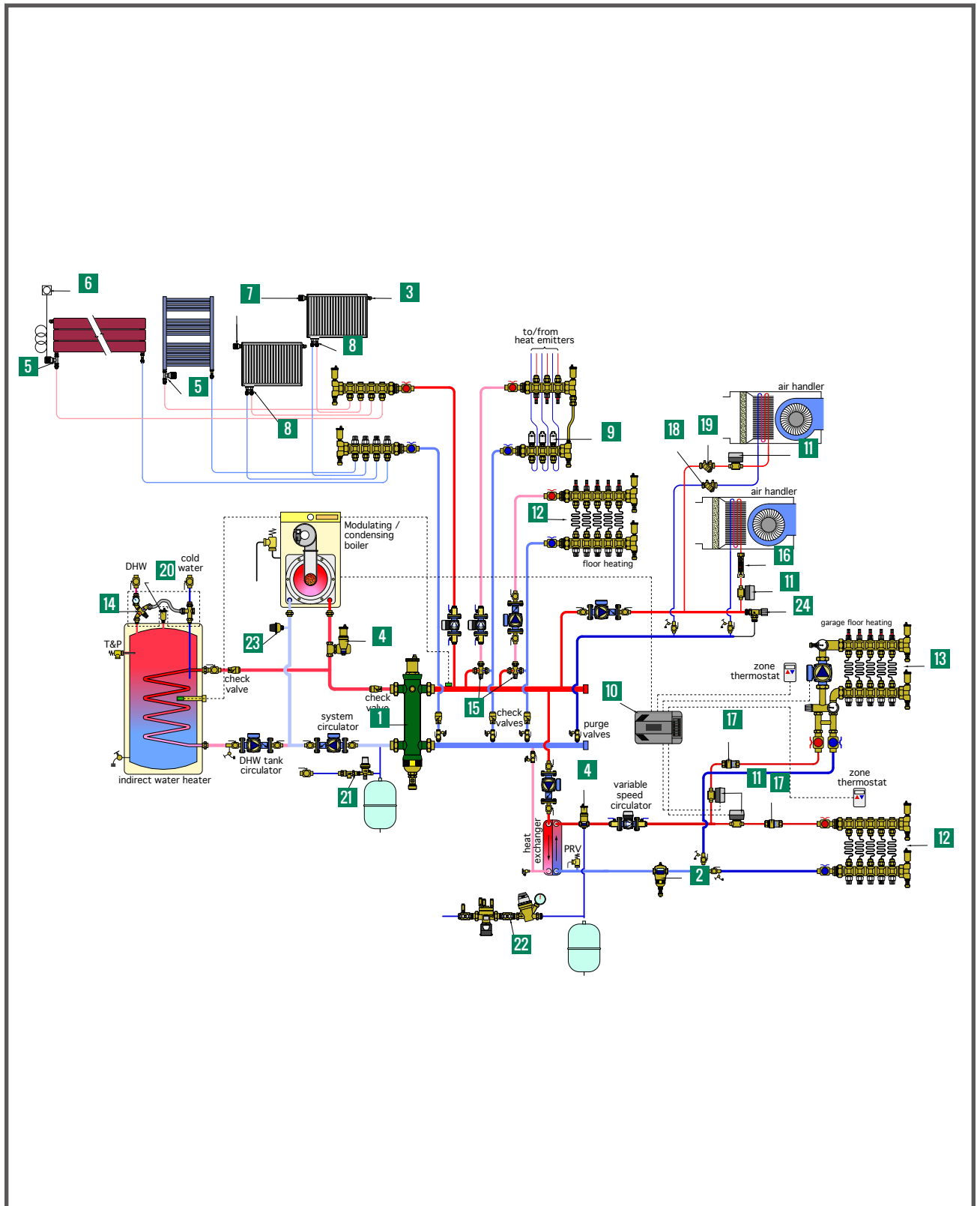

Key	Part Number	Description	Pages #
<b>1</b>	<b>549506A</b>	SEP4™ hydraulic, air, dirt, mag separator	<b>12</b>
<b>2</b>	<b>546328AM</b>	DIRTMAG® PRO magnetic dirt separator	<b>24</b>
<b>3</b>	<b>508013A</b>	Hygroscopic air vent	<b>29</b>
<b>4</b>	<b>551706A</b>	DISCAL® air separator, rotating collar	<b>20</b>
<b>5</b>	<b>221500</b>	Radiator valve	<b>33</b>
<b>6</b>	<b>472000</b>	Remote wall sensor	<b>32</b>
<b>7</b>	<b>200000</b>	Radiator valve control head	<b>32</b>
<b>8</b>	<b>301040</b>	Radiator connection valves	<b>34</b>
<b>9</b>	<b>656344</b>	TwisTop™ thermo-electric actuator	<b>40 &amp; 52</b>
<b>10</b>	<b>ZVR103</b>	Z-one™ valve relay control	<b>44</b>
<b>11</b>	<b>Z55P</b>	Z-one™ valve assembly	<b>41</b>
<b>12</b>	<b>6686E5S1A</b>	TwistFlow™ manifold	<b>50</b>
<b>13</b>	<b>1725E1AHE</b>	Manifold mixing station	<b>48</b>
<b>14</b>	<b>520510AX</b>	TankMixer™ thermostatic mixing assembly	<b>65</b>
<b>15</b>	<b>521619A</b>	MixCal™ thermostatic mixing valve	<b>57</b>
<b>16</b>	<b>132662A</b>	QuickSetter™ balancing valve	<b>69</b>
<b>17</b>	<b>127361AF</b>	FlowCal™ automatic balancing valve	<b>75</b>
<b>18</b>	<b>128556AF</b>	FlowCal™	<b>74</b>
<b>19</b>	<b>128756 000</b>	Y-strainer	<b>96</b>
<b>20</b>	<b>NA502640A</b>	PLUMBVENT™ low lead automatic air vent	<b>101</b>
<b>21</b>	<b>573002A</b>	AutoFill™ combo ASSE 1012	<b>106</b>
<b>22</b>	<b>574151A</b>	AutoFill™ combo ASSE 1013	<b>107</b>
<b>23</b>	<b>626600A</b>	Paddle flow switch	<b>117</b>
<b>24</b>	<b>519600A</b>	Differential pressure bypass valve	<b>117</b>

# EXPLORE OUR EXCELLENCE IN EDUCATION



Caleffi is committed to providing not only high quality and innovative products but also delivering **outstanding educational resources** to aid in heating, cooling and plumbing system design, configurations and problem solving. We are flexible to assist with customized or hybrid training. For more information, visit [caleffi.com](http://caleffi.com) or contact us at [marketingadmin@caleffi.com](mailto:marketingadmin@caleffi.com). **CALEFFI GUARANTEED.**

# AWARD-WINNING PLUMBING INNOVATION



2014

2018

2019

2020

2021

2022

2023

We are honored to be recognized by the AHR Innovation Award judges over the years. Caleffi's success is based on listening to the marketplace combined with a total commitment to quality. The result? Creative product design, superior performance and support that exceeds our customers' expectations. **CALEFFI GUARANTEED.**



# Plumbing Product Selector

## Commercial

Use 5213 TubMixer™ for high flow fixtures



5

Alternatives to LEGIOMIX® motorized valve

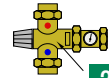

2

variable speed recirculation circulator  
return temperature sensor  
supply temperature sensor

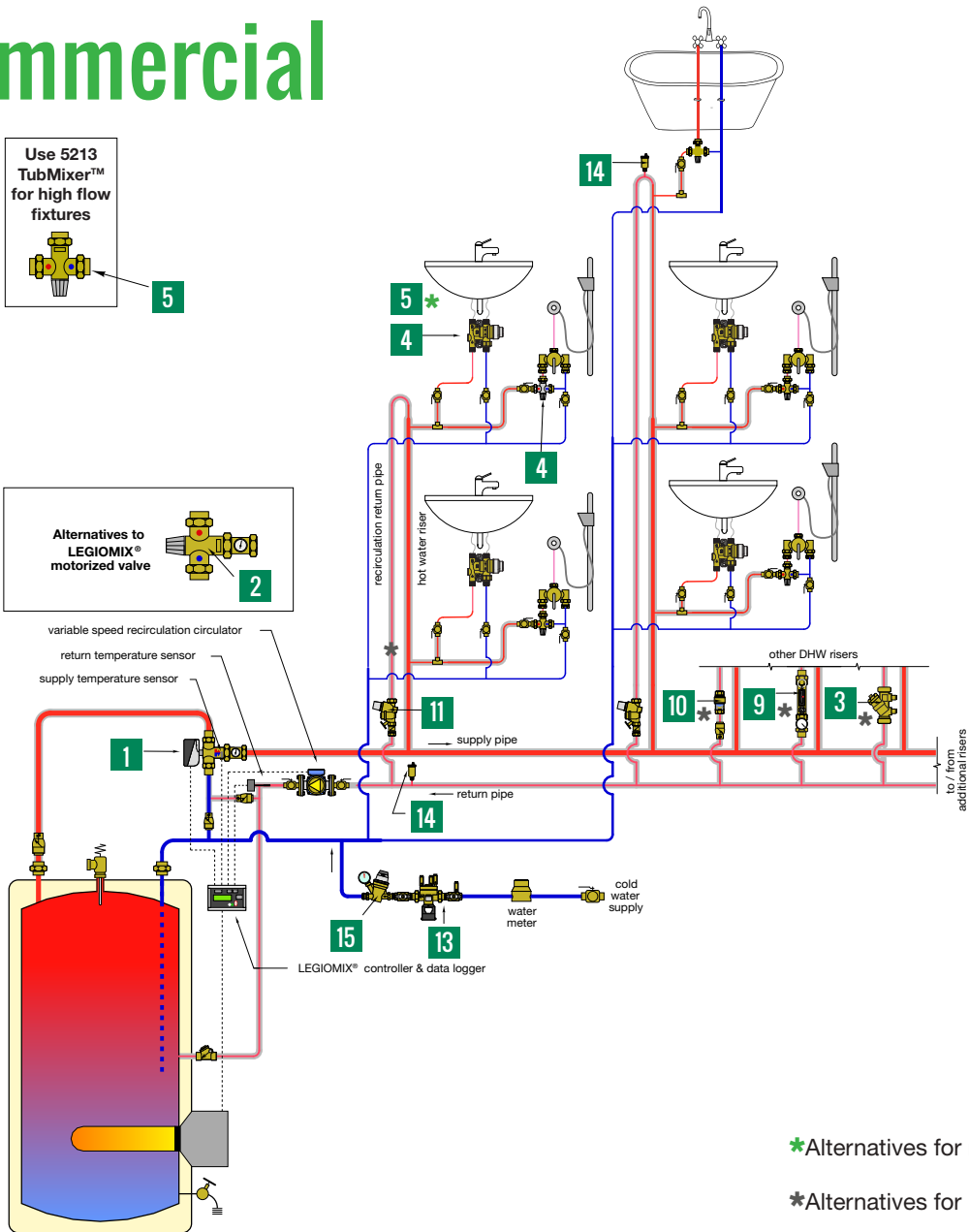

\*Alternatives for mixing.

\*Alternatives for balancing.

Key	Part Number	Description	Catalog Pages
1	600074A	LEGIOMIX® electronic mixing valve ASSE 1017	62
2	523177A*	High-flow mixing valve ASSE 1017	58
3	128456AF*	FlowCal+™ dynamic balancing valve	73
4	521201A	SinkMixer™ scald protection valve ASSE 1070	61
5	521333A	TubMixer™ scald protection mixing valve ASSE 1070	61
6	520516AX	TankMixer™ mixing valve assy ASSE 1017	65
7	520616A	AngleMix™ with valve with gauge ASSE 1017	60
8	521616A	MixCal™ mixing valve ASSE 1017	57



# Residential

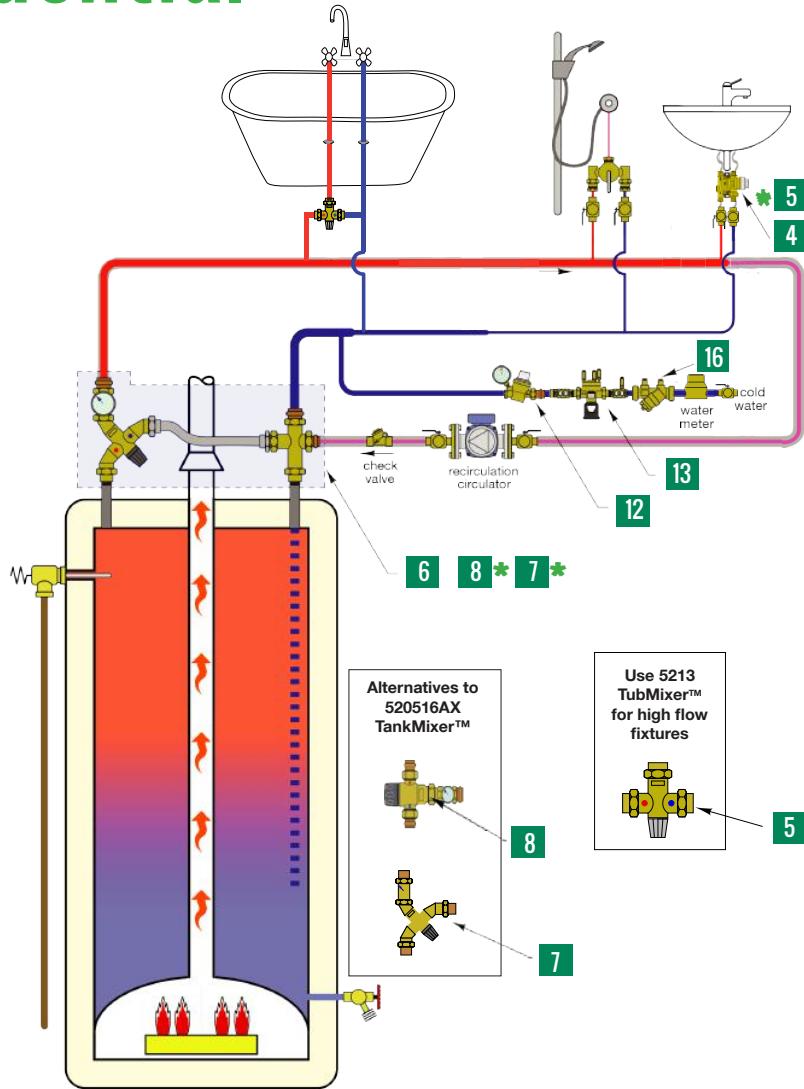

\*Alternatives for mixing.

Key	Part Number	Description	Catalog Pages
9	132537AFC	QuickSetter+™ manual balancing valve	68
10	127356AF*	FlowCal™ automatic balancing valve	75
11	116151AC	ThermoSetter™ thermal balancing valve	80
12	533351HA	PresCal™ pressure reducing valve ASSE 1003	86
13	574050A	RPZ backflow preventer ASSE 1013	90
14	NA502640A	PLUMBVENT™ low lead automatic air vent	101
15	535991HA	PresCal™ pressure reducing valve ASSE 1003	84
16	128741 000	FlowCal+™ union Y-strainer	96

# SEP4™ 4-IN-1 HIGH PERFORMANCE HYDRAULIC SEPARATORS



The Caleffi **SEP4™** hydraulic separator saves on system installation and maintenance costs by conveniently combining four high performance separation functions into one device: 1. Air 2. Hydraulic 3. Dirt 4. Magnetic. Enjoy trouble-free operating life with SEP4. **CALEFFI GUARANTEED.**



# HYDRAULIC SEPARATORS

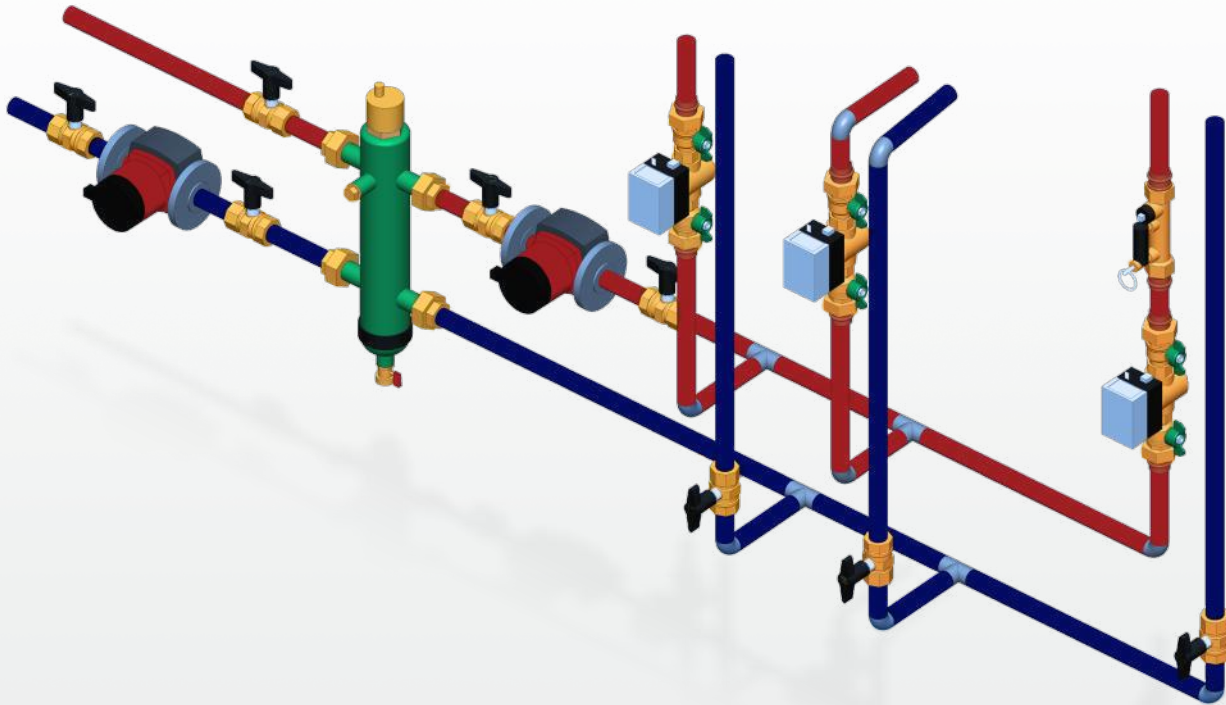

This diagram is for illustration purposes only



- PRODUCTS INCLUDED IN SECTION**
- 4-in-1 hydraulic separators
  - Hydraulic separators
  - Combination hydraulic separator and manifold
  - Hydraulic separator accessories

4-IN-1 HYDRAULIC SEPARATORS



**5495  
SEP4™**

**Combination 1. air, 2. hydraulic, 3. dirt separation, 4. magnetic separation.**  
Epoxy resin coated steel body.  
HDPE internal coalescing element, removable for cleaning.  
Includes mounting bracket.  
Thermowell tap: ½" straight female.  
Max. working pressure: 150 psi.  
Working temperature range: 32°–212°F.

Code	Description	Lbs	USD
549596A	1" sweat union	15	749.00
549506A	1" NPT female union	15	779.00
549566A	1" press union	15	819.00
549597A	1¼" sweat union	19	914.00
549507A	1¼" NPT female union	19	944.00
549567A	1¼" press union	19	1,038.00
549598A	1½" sweat union	27	1,193.00
549508A	1½" NPT female union	27	1,235.00
549568A	1½" press union	27	1,348.00
549599A	2" sweat union	29	1,368.00
549509A	2" NPT female union	29	1,402.00
549569A	2" press union	29	1,574.00
549506US*	1" no tailpieces	13	638.00
549507US*	1¼" no tailpieces	16	745.00
549508US*	1½" no tailpieces	23	878.00
549509US*	2" no tailpieces	24	1,064.00

\*See Separator fittings in Section 8.



**NA549  
SEP4™**

**Combination 1. air, 2. hydraulic, 3. dirt separation, 4. magnetic separation.**  
Epoxy resin coated steel body.  
Stainless steel internal coalescing mesh.  
Pre-formed insulation on 2" – 4" sizes.  
One neodymium magnet assembly.  
Complete with:  
automatic air vent (code 501502A).  
air vent shut-off valve (code NA39589).  
1" drain valve NA39753 (2" – 4" sizes)  
1¼" drain valve NA39588 (5" – 6" sizes).  
ANSI 150 flange connections.  
Max. working pressure: 150 psi.  
Vessel temperature range: 32°–220°F.  
Working temp. w/o insulation: 32°–270°F.  
Particle separation capacity: to 5 µm (0.2 mil).

Code	Description	Lbs	USD
549552A	2" ANSI flange	76	5,852.00
549562A	2½" ANSI flange	82	6,237.00
549582A	3" ANSI flange	112	7,805.00
549510A	4" ANSI flange	120	8,741.00

Code	Description	Lbs	USD
NA549052AM	2" ANSI flange ASME & CRN	76	6,812.00
NA549062AM	2½" ANSI flange ASME & CRN	82	7,315.00
NA549082AM	3" ANSI flange ASME & CRN	112	9,053.00
NA549102AM	4" ANSI flange ASME & CRN	120	9,546.00
NA549120AM*	5" ANSI flange ASME & CRN	220	13,750.00
NA549150AM*	6" ANSI flange ASME & CRN	235	16,587.00

\*Without insulation

NA prefix indicates ASME U-stamp tagged and registered with the National Board of Boiler and Pressure Vessel Inspectors; CRN registered.



**NA549  
SEP4™  
ASME**

**Combination 1. air, 2. hydraulic, 3. dirt separation, 4. magnetic separation.**  
Three neodymium magnet assemblies.  
Complete with:  
automatic air vent (code 501502A).  
air vent shut-off valve (code NA39589).  
drain valve (code NA59600).  
ANSI 150 flange connections.  
Thermometer pockets (NPT):  
½" inlet/outlet flanges, ¾" front center  
Max. working pressure: 150 psi.  
Vessel temperature range: 32°–270°F.  
Particle separation capacity: to 5 µm (0.2 mil).  
CRN registered through 12". Consult factory for 14".

Code	Description	Lbs	USD
NA549200AM	8" ANSI flange ASME & CRN	530	28,709.00
NA549250AM	10" ANSI flange ASME & CRN	740	38,897.00
NA549300AM	12" ANSI flange ASME & CRN	1,110	51,187.00
NA549350AM	14" ANSI flange ASME	1,550	60,346.00



In the SEP4™ hydraulic separators ferrous impurities are captured by a concentrated magnetic field created by a stack of neodymium magnetic rods, rare-earth magnets positioned inside a brass dry-well which is below the flow stream. Non-magnetic dirt particles are separated by colliding with an internal element in the flow stream and settling to the bottom. The deep collection chamber keeps the dirt from re-entering the flow stream. The dirt and ferrous impurities are flushed out even while the system is still running, by removing the magnets and opening the purge valve.

Size	1"	1¼"	1½"	2"
GPM	11	18	26	37
Gallons	0.5	0.7	1.3	3.5

Size	2"	2½"	3"	4"	5"	6"	8"	10"	12"	14"
GPM	60	80	124	247	300	484	792	1330	1850	2500
Gallons	4.0	4.0	8.0	8.0	23	23	95	175	255	450

**HYDRAULIC SEPARATORS**



**548 Hydro Separator**

Hydraulic separator.  
Epoxy resin coated steel body.  
300 Series stainless steel internal baffle.  
Includes mounting bracket.  
Thermowell tap: ½" straight female  
Max. working pressure: 150 psi.  
Working temperature range: 32° – 212°F.

Code	Description	Lbs	USD
548006A	1" NPT female union	13	542.00
548066A	1" press union	13	581.00
548096A	1" sweat union	13	514.00
548007A	1¼" NPT female union	17	650.00
548067A	1¼" press union	17	739.00
548097A	1¼" sweat union	17	620.00
548008A	1½" NPT female union	25	852.00
548068A	1½" press union	25	959.00
548098A	1½" sweat union	25	811.00
548009A	2" NPT female union	27	993.00
548069A	2" press union	27	1,211.00
548099A	2" sweat union	27	948.00
548006US*	1" no tailpieces	11	408.00
548007US*	1¼" no tailpieces	14	459.00
548008US*	1½" no tailpieces	21	509.00
548009US*	2" no tailpieces	22	561.00

\*See Separator fittings in Section 8.



**NA548 Hydro Separator ASME**

Hydraulic separator.  
Without insulation.  
Complete with:  
automatic air vent (code 501502A).  
shut-off valve (code NA39589).  
drain valve (code NA59600).  
ANSI 150 flange connections.  
Thermometer pockets (NPT):  
½" inlet/outlet flanges, ¾" front center.  
Max. working pressure: 150 psi.  
Working temperature range: 32° – 270°F.  
Baffle plates for all sizes: 304SST  
ASME U-stamp tagged and registered with the National Board of Boiler and Pressure Vessel Inspectors; CRN registered through 12". Consult factory for 14".

Code	Description	Lbs	USD
NA548200A	8" ANSI flange ASME & CRN	530	19,248.00
NA548250A	10" ANSI flange ASME & CRN	740	27,169.00
NA548300A	12" ANSI flange ASME & CRN	1,110	32,885.00
NA548350A	14" ANSI flange ASME	1,550	52,443.00



**NA548 Hydro Separator**

Hydraulic separator.  
Epoxy resin coated steel body.  
Pre-formed insulation on 2" – 4" sizes.  
Complete with:  
automatic air vent (code 501502A).  
shut-off valve (code NA39589).  
drain valve (code NA39588).  
ANSI 150 flange connections.  
Max. working pressure: 150 psi.  
Vessel temperature range: 32° – 220°F.  
Vessel temp. w/o insulation: 32° – 270°F.  
Baffle plates for all sizes: 304 SS

Code	Description	Lbs	USD
548052A	2" ANSI flange	75	3,868.00
548062A	2½" ANSI flange	82	4,118.00
548082A	3" ANSI flange	112	5,155.00
548102A	4" ANSI flange	117	5,768.00

Code	Description	Lbs	USD
NA548052A	2" ANSI flange ASME & CRN	75	5,088.00
NA548062A	2½" ANSI flange ASME & CRN	82	5,470.00
NA548082A	3" ANSI flange ASME & CRN	112	6,621.00
NA548102A	4" ANSI flange ASME & CRN	117	7,000.00
NA548120A*	5" ANSI flange ASME & CRN	220	10,222.00
NA548150A*	6" ANSI flange ASME & CRN	231	12,404.00

NA prefix indicates ASME U-stamp tagged and registered with the National Board of Boiler and Pressure Vessel Inspectors; CRN registered.

\*Without insulation



**NA549 HydroCal™ ASME**

**Combination 1. air, 2. hydraulic, 3. dirt separation.**

Epoxy resin coated steel body.  
Stainless steel internal coalescing mesh.  
Pre-formed insulation on 2" – 4" sizes.  
Complete with: automatic air vent, air vent shut-off valve, drain valve.  
ANSI 150 flange connections.  
Max. working pressure: 150 psi.  
Vessel temperature range: 32° – 220°F.  
Working temp. w/o insulation: 32° – 270°F.  
Particle separation capacity: to 5 µm (0.2 mil).  
CRN registered through 12".  
Consult factory for 14".

Code	Description	Lbs	USD
NA549052A	2" ANSI flange ASME & CRN	73	6,614.00
NA549062A	2½" ANSI flange ASME & CRN	79	7,114.00
NA549082A	3" ANSI flange ASME & CRN	108	8,603.00
NA549102A	4" ANSI flange ASME & CRN	117	9,097.00
NA549120A*	5" ANSI flange ASME & CRN	190	13,283.00
NA549150A*	6" ANSI flange ASME & CRN	231	16,116.00
NA549200A*	8" ANSI flange ASME & CRN	520	26,039.00
NA549250A*	10" ANSI flange ASME & CRN	730	36,225.00
NA549300A*	12" ANSI flange ASME & CRN	1,100	48,517.00
NA549350A*	14" ANSI flange ASME	1,540	57,676.00

\*Without insulation

**COMBINATION HYDRAULIC SEPARATOR AND MANIFOLD**

**5599 HydroLink™**

Hydraulic separator + distribution manifold. 2+0 with built-in mounting. Steel body with pre-formed insulation. Complete with automatic air vent (code 502043A) and drain valve (code 538402 FD).  
 Max. working pressure: 100 psi.  
 Working temperature range: 32°—230°F.  
 Outlet center dimension: 125 mm.  
 Compatible with 166, 167 Series HydroMixer™.



Code	Description	Lbs	USD
<b>559920A</b>	1" FNPT primary, 1" MNPT secondary (2)	16	<b>809.00</b>

**5599 HydroLink™**

Hydraulic separator + distribution manifold. 2+2 with angle mounting brackets. Steel body with pre-formed insulation. Complete with automatic air vent (code 502043A) and drain valve (code 538402 FD).  
 Max. working pressure: 100 psi.  
 Working temperature range: 32°—230°F.  
 Outlet center dimension: 125 mm.  
 Compatible with 166, 167 Series HydroMixer™.



Code	Description	Lbs	USD
<b>559922A</b>	1/4" FNPT primary, 1" MNPT secondary (4)	29	<b>994.00</b>

**5599 HydroLink™**

Hydraulic separator + distribution manifold. 2+1 with built-in mounting. Steel body with pre-formed insulation. Complete with automatic air vent (code 502043A) and drain valve (code 538402 FD).  
 Max. working pressure: 100 psi.  
 Working temperature range: 32°—230°F.  
 Outlet center dimension: 125 mm.  
 Compatible with 166, 167 Series HydroMixer™.



Code	Description	Lbs	USD
<b>559921A</b>	1" FNPT primary, 1" MNPT secondary (3)	16	<b>833.00</b>

**5599 HydroLink™**

Hydraulic separator + distribution manifold. 3+1 with angle mounting brackets. Steel body with pre-formed insulation. Complete with automatic air vent (code 502043A) and drain valve (code 538402 FD).  
 Max. working pressure: 100 psi.  
 Working temperature range: 32°—230°F.  
 Outlet center dimension: 125 mm.  
 Compatible with 166, 167 Series HydroMixer™.



Code	Description	Lbs	USD
<b>559931A</b>	1/4" FNPT primary, 1" MNPT secondary (4)	39	<b>1,194.00</b>

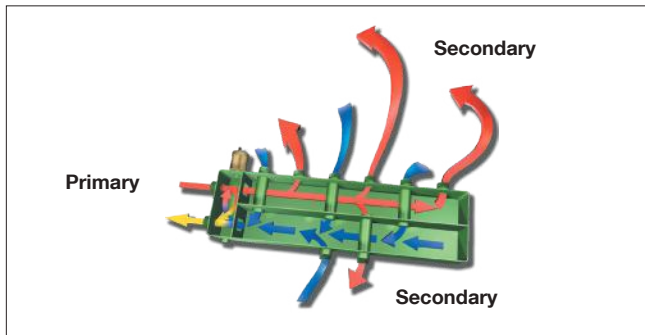

**Maximum recommended flow rates at connections:**

Branches	Primary	Secondary Total
2+0	9 gpm	22 gpm
2+1	9 gpm	22 gpm
2+2	11 gpm	26 gpm
3+1	11 gpm	26 gpm

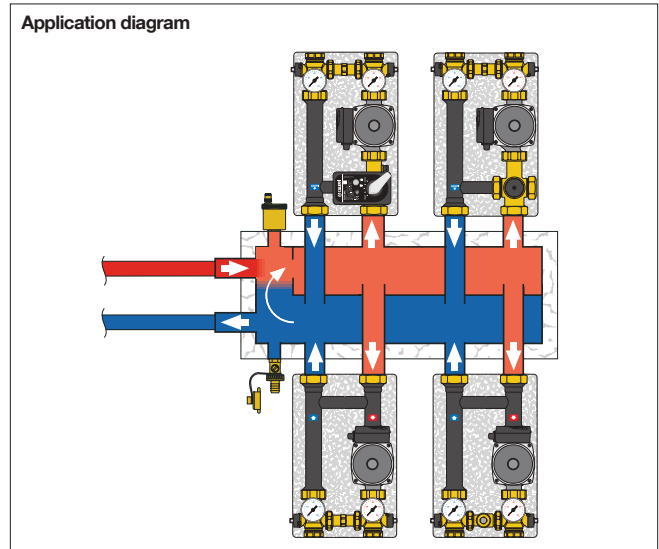

**HYDRAULIC SEPARATOR ACCESSORIES**



**501  
MAXCAL™**

Replacement air vent for Hydro Separator. Fits NA548 Series and NA549 Series. Max. working pressure: 230 psi. Max. discharge pressure: 90 psi. Max. working temperature: 250°F. Discharge top thread: 3/8" female.

Code	Description	Lbs	USD
<b>501502A</b>	3/4" FNPT	7.0	<b>324.00</b>



**5020  
MINICAL™**

Replacement high capacity air vent for 5599 HydroLink™. Max. working pressure: 150 psi. Max discharge pressure: 32 psi. Max. working temperature: 250°F.

Code	Description	Lbs	USD
<b>502043A</b>	1/2" MNPT	0.6	<b>24.50</b>



**5023  
VALCAL™**

Replacement high capacity air vent with service check valve fits Hydro Separator 548 Series. Max. working pressure: 150 psi. Max. discharge pressure: 60 psi. Max. working temperature: 250°F.

Code	Description	Lbs	USD
<b>502343A</b>	1/2" MNPT	0.5	<b>49.60</b>



Support bracket for SEP4 and Hydro Separator.

Code	Description	Lbs	USD
<b>NA10778</b>	for 1" and 1 1/4" union	2.0	<b>28.70</b>
<b>NA10796</b>	for 1 1/2" union	2.5	<b>30.00</b>
<b>NA10797</b>	for 2" union	4.0	<b>31.20</b>



Replacement drain valve fits Hydro Separator 548 Series and HydroLink™ 559 Series. 3/4" garden hose thread with cap. Max. working pressure: 150 psi. Max. working temperature: 250°F.

Code	Description	Lbs	USD
<b>538402 FD</b>	1/2" NPT x 3/4" GHT	0.3	<b>15.60</b>



Drain ball valves fit HydroCal™, Hydro Separators, DISCAL®, DISCALDIRT® and DIRTICAL®. Brass body. Max. working pressure: 150 psi. Max. working temperature: 365°F.

Code	Description	Lbs	USD
<b>NA39589</b>	3/4" FNPT w/T-handle, air vent isolate	0.8	<b>32.20</b>
<b>NA39753</b>	1" FNPT w/Lever, drain	0.7	<b>43.90</b>
<b>NA39588</b>	1 1/4" FNPT w/Lever, drain	1.0	<b>73.90</b>
<b>NA59600</b>	2" FNPT w/Lever, drain	4.0	<b>156.00</b>



Temperature pocket well fits 1", 1 1/4", 1 1/2" & 2" 548 / 5495 Hydro Separators. 1 3/4" pocket length. Inside thread: 20 x1.0 mm.

Code	Description	Lbs	USD
<b>694045</b>	1/2" straight thread	0.2	<b>19.80</b>
<b>R20011</b>	Sealing washer	0.1	<b>1.60</b>
<b>NA10426</b>	Sensor holding grommet	0.1	<b>4.50</b>
<b>NA10425</b>	Kit containing above 3 items	0.4	<b>26.50</b>



Magnetic/drywell assembly for SEP4™.

Code	Description	Lbs	USD
<b>F0000435</b>	Fits 2" and 2 1/2"	0.3	<b>141.00</b>
<b>49684A</b>	Fits 3" — 6"	0.3	<b>318.00</b>
<b>F0000349</b>	Fits 8" to 14"	0.3	<b>600.00</b>



Insulation jacket kit for SEP4™ and Hydro Separator.

Code	Description	Lbs	USD
<b>NA10801</b>	for 1" union 5495	0.5	<b>50.00</b>
<b>NA10802</b>	for 1 1/4" union 5495	0.5	<b>54.90</b>
<b>NA10803</b>	for 1 1/2" union 5495	0.6	<b>75.00</b>
<b>NA10804</b>	for 2" union 5495	0.6	<b>84.90</b>
<b>NA10805</b>	for 1" union 548	0.5	<b>32.40</b>
<b>NA10806</b>	for 1 1/4" union 548	0.5	<b>37.50</b>
<b>NA10807</b>	for 1 1/2" union 548	0.6	<b>46.20</b>
<b>NA10808</b>	for 2" union 548	0.6	<b>53.80</b>

# THE GOLD STANDARD SEPARATION WITH NO COMPROMISE



Make a smart choice by selecting **The Gold Standard Kit** for clean hydronic systems to ensure maximum protection and efficiency. The Kit includes two product favorites that effectively eliminate three problems:

The **DISCAL**® high efficiency air separator is dedicated to removing the system culprit: ① **excessive oxygen** resulting in the formation of **corrosion**. The **DIRTMAG**® PRO dirt separator with magnetic technology and particle mesh captures troublesome ② **ferrous** and ③ **non-ferrous debris**. **CALEFFI GUARANTEED.**





# AIR AND DIRT SEPARATORS AND AIR VENTS

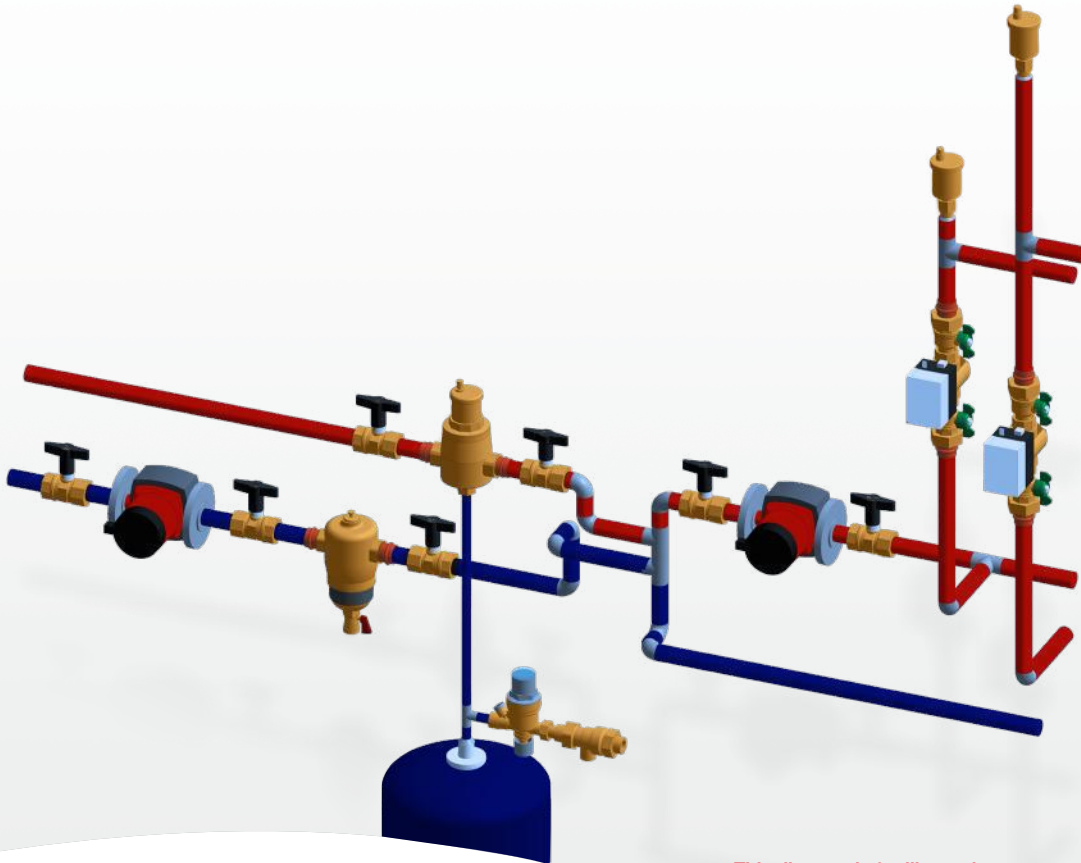

This diagram is for illustration purposes only



## PRODUCTS INCLUDED IN SECTION

- Gold standard kits
- Air separators
- Dirt separators
- Combination air and dirt separators
- Magnetic dirt separators
- Accessories for air and dirt separators
- Automatic and manual air vents

GOLD STANDARD KITS

NEW



551 Gold Standard Kit™

DISCAL®

Air separator.  
 Brass body.  
 Stainless steel float guide pin and linkage.  
 Glass reinforced nylon internal element.

DIRTMAG® PRO

Dirt separator with exclusive dual magnetic fields.  
 - Internal magnet in drywell.  
 - External clip-on magnet.  
 Brass body.

Maintaining the "health" of water based solutions that circulate through a hydronic system is of critical importance for its operation and protection of components. It is accomplished by preventing oxygen from reacting with ferrous materials resulting in corrosion and by removing ferrous and non-ferrous debris that are damaging to the system.

Rest assured. The **GOLD STANDARD** kit conveniently accomplishes these tasks. Separation with **NO** Compromise. **CALEFFI GUARANTEED.**

The DISCAL air separator keeps dissolved oxygen concentration below the level that can cause corrosion with ferrous materials. It has a unique bell shape geometry that slows the fluid velocity down by a 9 to 1 ratio. Coupled with a specially engineered coalescing mesh, the action forces micro-bubble gasses to be efficiently collected and automatically vented from the system. When properly placed within the system, DISCAL keeps the concentration of dissolved oxygen low, thus preventing unimpeded ferrous formation.

Protect the boiler (or chiller) with a magnetic dirt separator that collects not only ferrous but also non-ferrous debris. Problematic non-ferrous debris includes copper shavings, pipe tape, pipe sealant and solder. Piping and other equipment stored outside can collect dirt, silica, dust and insects. Calcium scale that forms and breaks off within a system is also non-ferrous. All of these non-ferrous debris types are not captured by a magnet. With the DIRTMAG PRO, purging the debris is easy, non-messy and doesn't require shutting down the system. Simply remove the top magnetic rod and the lower magnetic collar and open the drain valve to purge the captured impurities.

Code	Description	Lbs	USD
KIT551546 028	1" sweat	8.5	368.00
KIT551546 066	1" press	8.9	506.00
KIT551546 035	1¼" sweat	8.5	428.00
KIT551546 067	1¼" press	11.1	621.00

\*All kits include a DISCAL® and DIRTMAG® PRO.

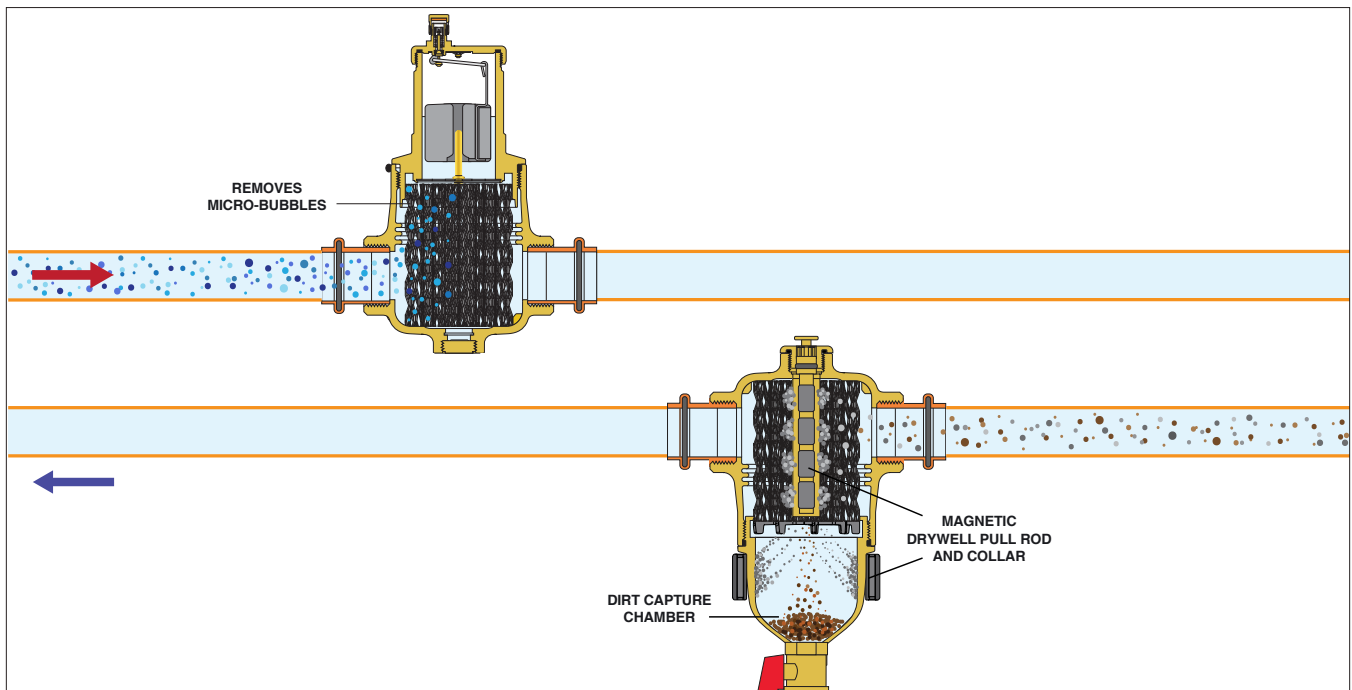

**AIR SEPARATORS**



**551 DISCAL®**

Air separator.  
Brass body.  
Stainless steel float guide pin and linkage.  
Glass reinforced nylon internal element.  
1/2" NPT female bottom thread.  
Max. working pressure: 150 psi.  
Working temperature range: 32°–250°F.

Code	Description	Lbs	USD
551005A	3/4" FNPT	3.7	<b>178.00</b>
551028A	1" sweat	3.7	<b>183.00</b>
551006A	1" FNPT	3.7	<b>192.00</b>
551066A	1" integral press	3.8	<b>218.00</b>
551035A	1 1/4" sweat	3.7	<b>266.00</b>
551007A	1 1/4" FNPT	4.9	<b>281.00</b>
551067A	1 1/4" integral press	5.0	<b>336.00</b>
551041A	1 1/2" sweat	4.9	<b>346.00</b>
551008A	1 1/2" FNPT	4.9	<b>364.00</b>
551068A	1 1/2" integral press	5.1	<b>434.00</b>
551054A	2" sweat	5.5	<b>424.00</b>
551009A	2" FNPT	5.5	<b>445.00</b>
551069A	2" integral press	5.5	<b>530.00</b>



**551 DISCAL® Service check**

Air separator with 1/2" service check valve (code 561402A) to mount expansion tank on bottom thread.  
Brass body.  
Stainless steel float guide pin and linkage.  
Glass reinforced nylon internal element.  
Max. working pressure: 150 psi.  
Working temperature range: 32°–250°F.

Code	Description	Lbs	USD
551005AC	3/4" FNPT	3.8	<b>185.00</b>
551028AC	1" sweat	3.8	<b>190.00</b>
551006AC	1" FNPT	3.8	<b>199.00</b>
551066AC	1" integral press	3.9	<b>224.00</b>
551035AC	1 1/4" sweat	3.8	<b>273.00</b>
551007AC	1 1/4" FNPT	5.0	<b>286.00</b>
551067AC	1 1/4" integral press	5.1	<b>343.00</b>
551041AC	1 1/2" sweat	5.0	<b>354.00</b>
551008AC	1 1/2" FNPT	5.0	<b>371.00</b>
551068AC	1 1/2" integral press	5.2	<b>441.00</b>
551054AC	2" sweat	5.6	<b>430.00</b>
551009AC	2" FNPT	5.6	<b>451.00</b>
551069AC	2" integral press	5.6	<b>537.00</b>

**ACCESSORIES**



Insulation shell fits DISCAL® 551 Series.

Code	Description	Lbs	USD
<b>CBN551005</b>	Fits 3/4" and 1" 551 Series	0.1	<b>59.10</b>
<b>CBN551007</b>	Fits 1 1/4" and 1 1/2" 551 Series	0.1	<b>63.30</b>
<b>CBN551009</b>	Fits 2" 551 Series	0.1	<b>69.30</b>

\*Will not fit the 3/4" compact DISCAL®; codes 551003A and 551022A.



Service check valve for easy replacement of expansion tank when connected to bottom of DISCAL®.

Code	Description	Lbs	USD
<b>561402A</b>	1/2" MNPT x 1/2" FNPT	0.2	<b>15.60</b>

Size	MAXIMUM FLOW RATE				
	3/4"	1"	1 1/4"	1 1/2"	2"
GPM	6	10	15	22	39
Cv	19	32	56	73	81

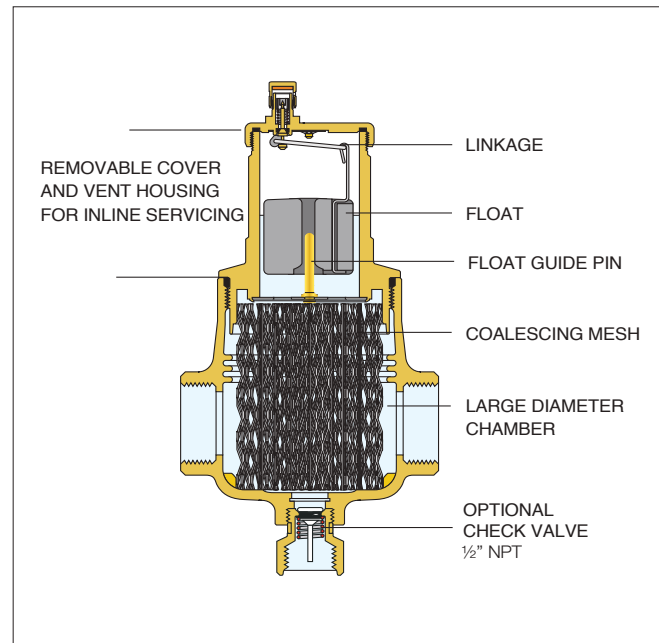

**COMBINATION AIR AND DIRT SEPARATORS**



**5517 DISCAL® Rotating collar**

Air separator with rotating collar for horizontal or vertical pipes.  
 Brass body.  
 Stainless steel float guide pin and linkage.  
 Stainless steel mesh internal element.  
 Max. working pressure: 150 psi.  
 Working temperature range: 32°–250°F.



**551 DISCAL® Compact**

Air separator.  
 Brass body.  
 Stainless steel float guide pin and linkage.  
 Stainless steel mesh internal element.  
 ½" NPT bottom thread.  
 Max. working pressure: 150 psi.  
 Working temperature range: 32°–250°F.

Code	Description	Lbs	USD
551705A	¾" NPT male union	4.9	<b>274.00</b>
551765A	¾" press union	4.9	<b>288.00</b>
551795A	¾" sweat union	4.9	<b>271.00</b>
551706A	1" NPT male union	4.9	<b>293.00</b>
551766A	1" press union	4.9	<b>322.00</b>
551796A	1" sweat union	4.9	<b>287.00</b>
551716*	body only, order unions separately	4.4	<b>250.00</b>

\*See fitting selection table in Section 8.

Code	Description	Lbs	USD
551003A	¾" FNPT	2.0	<b>119.00</b>
551003AC	¾" FNPT, service check valve	2.1	<b>125.00</b>
551022A	¾" sweat	2.0	<b>115.00</b>
551022AC	¾" sweat, service check valve	2.1	<b>122.00</b>

**Construction details DISCAL® Rotating collar**

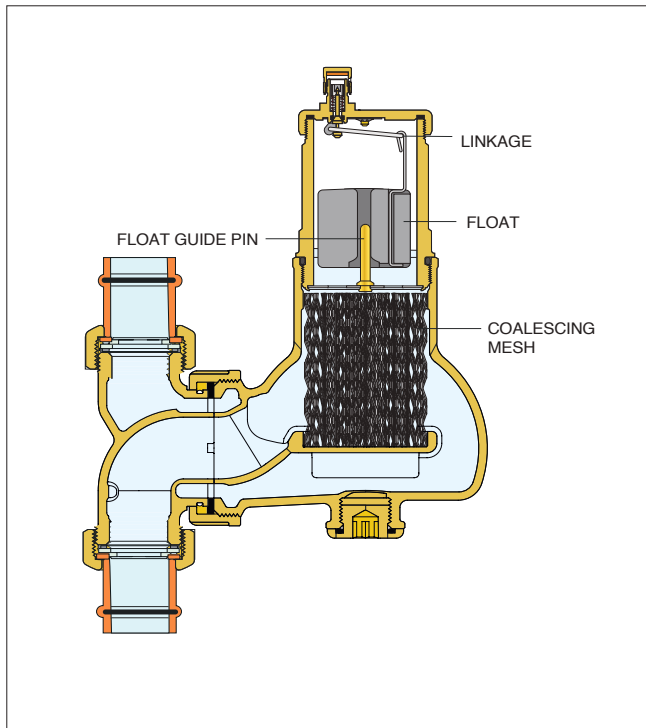

**Construction details DISCAL® Compact**

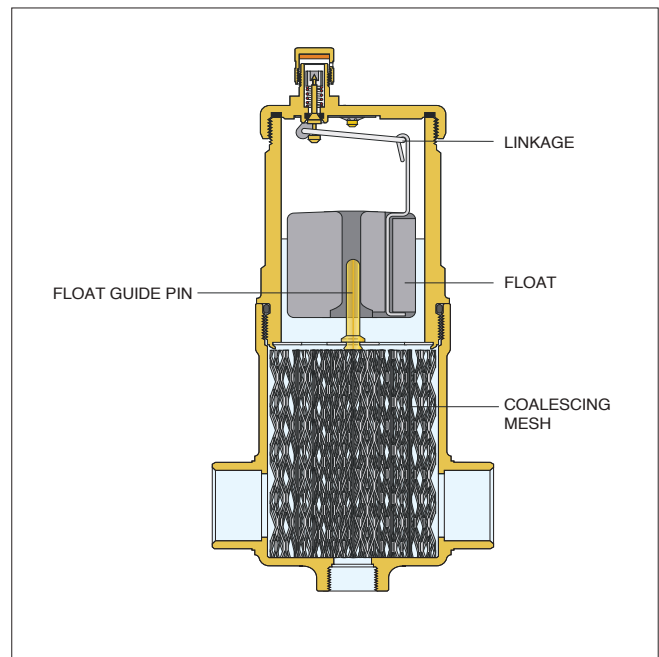

Size	MAXIMUM FLOW RATE		
	¾" compact	¾" vertical	1" vertical
GPM	6	6	10
Cv	12	19	19

COMBINATION AIR AND DIRT SEPARATORS



**551 DISCAL®**

Air separator.  
Epoxy resin coated steel body.  
Stainless steel float guide pin and linkage.  
Stainless steel mesh internal element.  
ANSI 150 flange connections.  
1" NPT male bottom drain connection.  
Complete with drain valve (NA39753).  
½" NPT male side drain connection.  
Complete with side drain valve (538402FD).  
Max. working pressure: 150 psi.  
Vessel temperature range: 32°—270°F.

Code	Description	Lbs	USD
551050A	2" ANSI flange	34	3,009.00
551050AT	2" MNPT	30	2,861.00
551060A	2½" ANSI flange	35	3,215.00
551060AT	2½" MNPT	31	3,069.00
551080A	3" ANSI flange	62	4,257.00
551100A	4" ANSI flange	67	4,762.00
551150A	6" ANSI flange	117	9,338.00

**Air separator construction**

DISCAL® air separators are constructed to allow maintenance and cleaning operations to be carried out without having to remove the separator body from the pipe work. All DISCAL air separators have a bottom connection drain valve. All internal air release control components are fully accessible. The automatic air release valve, located at the top of the separator, has a long chamber for the movement of the float. This feature prevents any debris present in the water from reaching the sealing seat.

Flanged models include a side drain vent to release large amounts of air when filling the system and to remove any debris present above the water level.

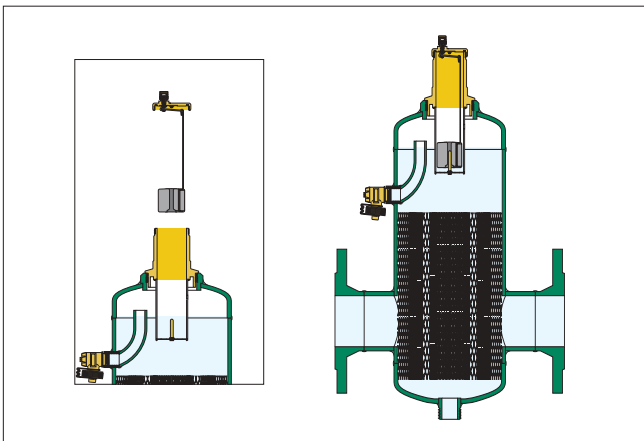

**MAXIMUM FLOW RATE**

Size	2"	2½"	3"	4"	5"	6"	8"	10"	12"
GPM	100	155	220	400	615	880	1,570	2,450	3,525
Cv	87	174	208	324	520	832	1,109	1,387	1,664



**NA551 DISCAL® ASME/CRN**

Air separator.  
Epoxy resin coated steel body.  
Stainless steel float guide pin and linkage.  
Stainless steel mesh internal element.  
ANSI 150 flange connections.  
1" NPT male bottom drain connection.  
Complete with drain valve (NA39753).  
½" NPT male side drain connection.  
Complete with side drain valve (538402FD).  
Max. working pressure: 150 psi.  
Vessel temperature range: 32°—270°F.  
ASME and CRN registered.

Code	Description	Lbs	USD
NA551050A	2" ANSI flange ASME & CRN	34	3,769.00
NA551060A	2½" ANSI flange ASME & CRN	35	4,029.00
NA551080A	3" ANSI flange ASME & CRN	62	5,333.00
NA551100A	4" ANSI flange ASME & CRN	67	5,968.00
NA551120A	5" ANSI flange ASME & CRN	106	6,864.00
NA551150A	6" ANSI flange ASME & CRN	117	11,189.00

NA prefix indicates ASME tagged and registered with the National Board of Boiler and Pressure Vessel Inspectors; CRN registered.

**NA551 DISCAL® ASME**



Air separator.  
Epoxy resin coated steel body.  
Stainless steel float guide pin and linkage.  
Stainless steel mesh internal element.  
ANSI 150 flange connections.  
2" NPT male bottom drain connection.  
Complete with drain valve (NA59600).  
½" NPT male side drain connection.  
Complete with side drain valve (538402FD).  
Max. working pressure: 150 psi.  
Vessel temperature range: 32°—270°F.  
ASME and CRN registered.

Code	Description	Lbs	USD
NA551200A	8" ANSI flange ASME & CRN	371	18,311.00
NA551250A	10" ANSI flange ASME & CRN	617	27,462.00
NA551300A	12" ANSI flange ASME & CRN	871	35,703.00

NA prefix indicates ASME tagged and registered with the National Board of Boiler and Pressure Vessel Inspectors; CRN registered.



Replacement drain ball valve.  
Fits DISCAL® Series.  
Brass body.  
Lever.  
Max. working pressure: 150 psi.  
Max. working temperature: 365°F.

Code	Description	Lbs	USD
NA39753	1" FNPT with lever	0.7	43.90
NA59600	2" FNPT with lever	3.5	156.00

COMBINATION AIR AND DIRT SEPARATORS



**5461**  
**DISCALDIRTMAG™**

Air & Dirt separator with magnet.  
Brass body.  
Stainless steel float guide pin and linkage.  
Glass reinforced nylon internal element.  
Max. working pressure: 150 psi.  
Working temperature range: 32° – 250°F.  
Particle separation capacity: to 5 µm (0.2 mil).  
Ferrous impurities separation efficiency: 100%.

Code	Description	Lbs	USD
546196A	1" sweat	8.5	458.00
546166A	1" press	8.5	491.00
546116A	1" MNPT	8.5	479.00
546197A	1¼" sweat	8.5	547.00
546167A	1¼" press	8.5	619.00



**5461**  
**DISCALDIRTMAG™**

Air & Dirt separator with magnet.  
Epoxy resin coated steel body.  
Stainless steel float guide pin and linkage.  
Stainless steel mesh internal element.  
Complete with union connections.  
Max. working pressure: 150 psi.  
Working temperature range: 32° – 230°F.  
Particle separation capacity: to 5 µm (0.2 mil).  
Ferrous impurities separation efficiency: 100%.

Code	Description	Lbs	USD
546198A	1½" sweat union	22	1,376.00
546108A	1½" NPT female union	22	1,419.00
546168A	1½" press union	22	1,572.00
546199A	2" sweat union	23	1,443.00
546109A	2" NPT female union	23	1,497.00
546169A	2" press union	23	1,754.00

The **DISCALDIRTMAG™** air and dirt separator with magnet uses a patented external magnet ring for separation of ferrous impurities. The impurities are retained in the body of the dirt separator by the strong magnetic field created. The outer ring is removable from the body to allow the flushing of sludge.



**546**  
**DISCALDIRT®**

Air & Dirt separator.  
Brass body.  
Stainless steel float guide pin and linkage.  
Glass reinforced nylon internal element.  
Max. working pressure: 150 psi.  
Working temperature range: 32° – 250°F.  
Particle separation capacity: to 5 µm (0.2 mil).

Code	Description	Lbs	USD
546096A	1" sweat	8.3	362.00
546016A	1" MNPT	8.3	380.00
546097A	1¼" sweat	8.3	432.00



**546**  
**DISCALDIRT®**

Air & Dirt separator.  
Epoxy resin coated steel body.  
Stainless steel float guide pin and linkage.  
Stainless steel mesh internal element.  
1" NPT threaded bottom drain connection.  
Complete with side drain valve (538402 FD).  
ANSI 150 flange connections.  
Complete with drain valve (NA39753).  
Max. working pressure: 150 psi.  
Vessel temperature range: 32° – 270°F.  
Particle separation capacity: to 5 µm (0.2 mil).

Code	Description	Lbs	USD
546050A	2" ANSI flange	40	3,821.00
546060A	2½" ANSI flange	42	4,027.00
546080A	3" ANSI flange	73	5,187.00
546100A	4" ANSI flange	78	5,685.00
546120A	5" ANSI flange	181	8,573.00



Insulation shell for DISCALDIRT® & DISCALDIRTMAG™.

Code	Description	Lbs	USD
CBN546002	Fits 1", 1¼" brass 546 only	0.1	92.70
CBN546118	Fits 1½" steel 5461 only	0.1	116.00
CBN546119	Fits 2" steel 5461 only	0.1	133.00

MAXIMUM FLOW RATE				
Size	1"	1¼"	1½"	2"
GPM	10	15	22	39
Cv	32	40	50	79

COMBINATION AIR AND DIRT SEPARATORS

**NA546**  
**DISCALDIRT®**  
**ASME/CRN**



Air & Dirt separator.  
Epoxy resin coated steel body.  
Stainless steel float guide pin and linkage.  
Stainless steel mesh internal element.  
1" (2–6" sizes) and 2" (8–14" sizes)  
threaded NPT bottom drain connection.  
ANSI 150 flange connections.  
Complete with drain valve NA39753  
(2–6" sizes), NA59600 (8–14" sizes).  
Max. working pressure: 150 psi.  
Vessel temperature range: 32°–270°F.  
ASME registered. CRN registered thru 12".  
Consult factory for 14".

**NA546M**  
**DISCALDIRTMAG™**  
**ASME/CRN**



Air & Dirt separator with magnets.  
Epoxy resin coated steel body.  
Stainless steel float guide pin and linkage.  
Stainless steel mesh internal element.  
ANSI 150 flange connections.  
1" (2–6" sizes) and 2" (8–14" sizes)  
threaded NPT bottom drain connection.  
Complete with drain valve NA39753  
(2–6" sizes), NA59600 (8–14" sizes).  
Max. working pressure: 150 psi.  
Vessel temperature range: 32°–270°F.  
Particle separation capacity: to 5 µm (0.2 mil).  
Ferrous impurities separation efficiency: up  
to 100%.  
ASME registered. CRN registered thru 12".  
Consult factory for 14".

Code	Description	Lbs	USD
NA546050T	2" Threaded ASME & CRN	28	3,659.00
NA546060A	2½" ANSI flange ASME & CRN	42	4,921.00
NA546080A	3" ANSI flange ASME & CRN	73	6,337.00
NA546100A	4" ANSI flange ASME & CRN	78	6,949.00
NA546120A	5" ANSI flange ASME & CRN	181	10,023.00
NA546150A	6" ANSI flange ASME & CRN	188	12,783.00
NA546200A	8" ANSI flange ASME & CRN	355	23,746.00
NA546250A	10" ANSI flange ASME & CRN	555	36,510.00
NA546300A	12" ANSI flange ASME & CRN	825	45,654.00
NA546350A	14" ANSI flange ASME	950	57,729.00

ASME U-stamp tagged and registered with the National Board of Boiler and Pressure Vessel Inspectors; CRN registered, 2" – 12"; consult factory for 14".

Low head losses and high performance are maintained over time. The dirt separating action performed by the DISCALDIRT® air and dirt separator is based on using the internal element with concentric diamond pattern mesh surfaces instead of an ordinary filter. The element offers little resistance to the medium flow while ensuring dirt separation. These air and dirt separators are ideal for chilled water applications.

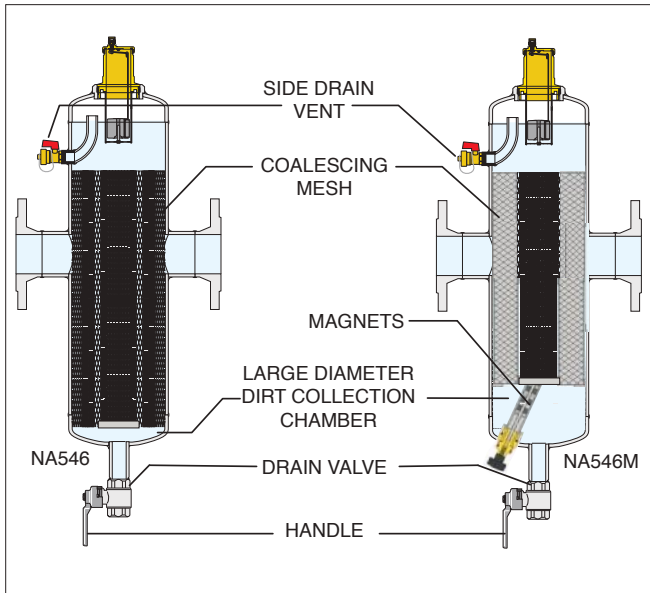

Code	Description	Lbs	USD
NA546050TM*	2" Threaded ASME & CRN	31	4,228.00
NA546060AM*	2½" ANSI flange ASME & CRN	45	5,528.00
NA546080AM*	3" ANSI flange ASME & CRN	76	7,193.00
NA546100AM*	4" ANSI flange ASME & CRN	81	7,821.00
NA546120AM*	5" ANSI flange ASME & CRN	184	11,486.00
NA546150AM*	6" ANSI flange ASME & CRN	191	13,860.00
NA546200AM**	8" ANSI flange ASME & CRN	365	27,191.00
NA546250AM**	10" ANSI flange ASME & CRN	565	39,260.00
NA546300AM**	12" ANSI flange ASME & CRN	835	49,748.00
NA546350AM**	14" ANSI flange ASME	960	62,176.00

\*With one magnet

\*\*With three magnets

ASME U-stamp tagged and registered with the National Board of Boiler and Pressure Vessel Inspectors. CRN registered, 2" – 12"; consult factory for 14".



In the DISCALDIRTMAG™ air and dirt separator with magnets, ferrous impurities are captured by a concentrated magnetic field created by a stack of neodymium rare-earth magnets positioned inside a brass dry-well which is below the flow stream. Non-magnetic dirt particles are separated by colliding with an internal element in the flow stream and settling to the bottom. The deep collection chamber keeps the dirt from re-entering the flow stream. The dirt and ferrous impurities are flushed out while the system is operating, by removing the magnets and opening the purge valve.

Size	MAXIMUM FLOW RATE									
	2"	2½"	3"	4"	5"	6"	8"	10"	12"	14"
GPM	100	155	220	400	615	880	1,570	2,450	3,525	4,800
Cv	87	174	208	324	520	832	1,109	1,387	1,664	1,967

MAGNETIC DIRT SEPARATORS



**5463M**  
**DIRTMAG® PRO**

Dirt separator with exclusive dual magnetic fields.  
 Internal magnet in drywell.  
 External clip-on magnet.  
 Brass body.  
 Max. working pressure: 150 psi.  
 Working temperature range: 32°–250°F.  
 Particle separation capacity: to 5µm (0.2 mil).  
 Ferrous impurities separation efficiency: 100%.

Code	Description	Lbs	USD
546328AM	1" sweat	4.7	226.00
546306AM	1" FNPT	4.7	237.00
546366AM	1" press	5.0	258.00
546335AM	1¼" sweat	4.7	329.00
546307AM	1¼" FNPT	5.8	345.00
546367AM	1¼" press	6.1	394.00
546341AM	1½" sweat	5.4	429.00
546308AM	1½" FNPT	6.7	451.00
546368AM	1½" press	7.0	514.00
546354AM	2" sweat	6.0	523.00
546309AM	2" FNPT	6.7	542.00
546369AM	2" press	7.0	627.00

**Construction design**

The DIRTMAG® PRO incorporates patented technology and features dual magnetic fields that increase ferrous debris removal efficiency by 40%. The concentric pattern collision media inside the low-velocity zone efficiently separates non-ferrous debris. All debris is quickly purged from system via the blow down valve. No disassembly or scraping of magnetite from immersed magnets is required, which means clean hands, fast, and easy servicing.

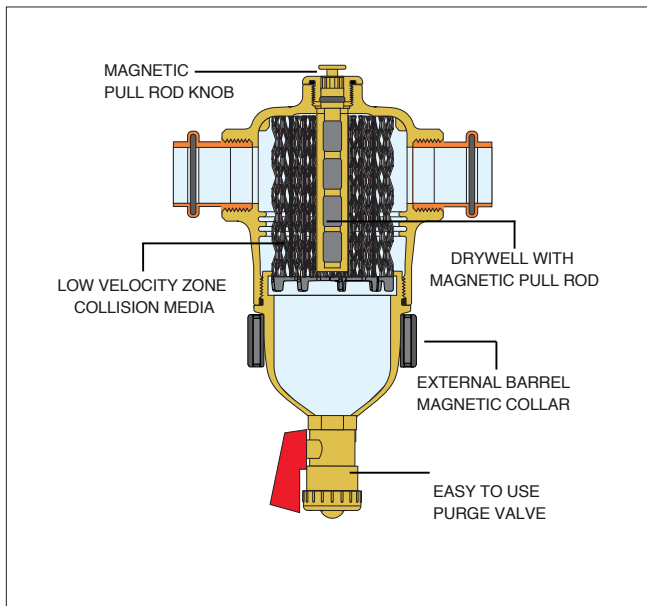

**Double the protection**

Captures two forms of debris that can damage or shorten the life of heat exchangers, circulators and valves: ferrous debris such as magnetite, and non-ferrous debris such as copper shavings, solder, lime-scale fragments, silica and pipe compound. Two powerful neodymium rare-earth magnetic fields attract and capture ferrous oxide impurities and allow simple blowdown - no disassembly required.

Combine the **DIRTMAG® PRO** with a **DISCAL®** air separator for **The Gold Standard Kit** found on page 18.

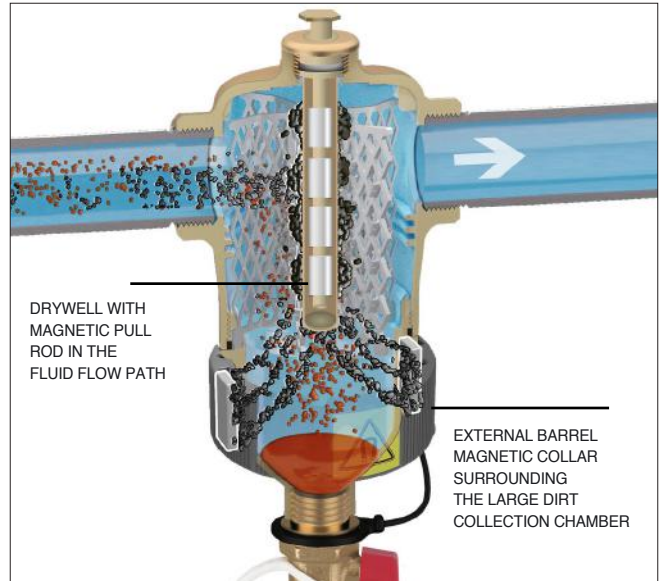

**Dirt separation comparison**

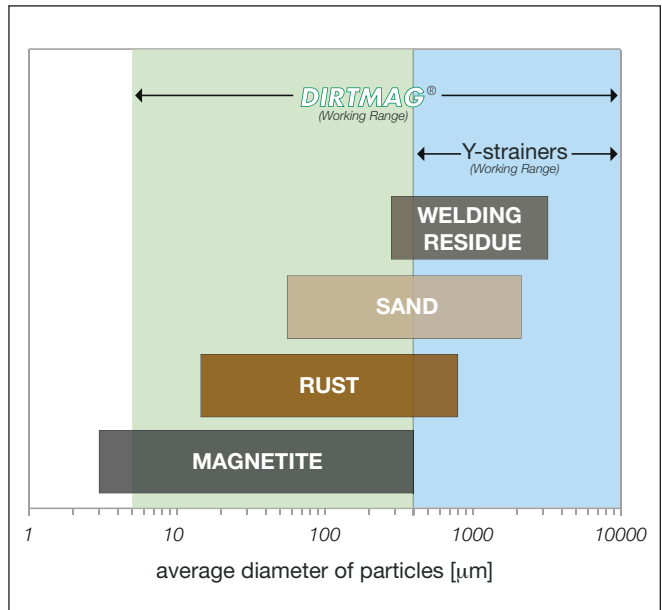

Size	MAXIMUM FLOW RATE			
	1"	1¼"	1½"	2"
GPM	14	21	31	54
Cv	32	45	69	104



**MAGNETIC DIRT SEPARATORS**



Insulation shell fits DIRTMAG® PRO 5463M Series.  
Labels included for field installation to externally identify product use.



Replacement drain valve fits DIRTMAG® Pro 5463M Series, brass DISCALDIRT® 546 Series and DISCALDIRTMAG™ 5461 Series. Brass body.  
Max. working pressure: 150 psi.  
Max. working temperature: 250°F.

Code	Description	Lbs	USD
<b>CBN546205</b>	Fits ¾" & 1" DIRTMAG® PRO	0.1	<b>56.20</b>
<b>CBN546207</b>	Fits 1¼" & 1½" DIRTMAG® PRO	0.1	<b>60.60</b>
<b>CBN546209</b>	Fits 2" DIRTMAG® PRO	0.1	<b>66.00</b>

Code	Description	Lbs	USD
<b>538402 FD</b>	½" MNPT x ¾" GHT	0.3	<b>15.60</b>

**Construction design**

The dirt separator with magnet combines the action of the internal element and magnet. The impurities in the water strike the internal element and are separated, dropping into the bottom of the body where they are collected. Ferrous impurities are also trapped inside the dirt separator body by two strong magnets contained within the removable outer ring collar. The collected impurities are discharged by removing the external ring magnet and opening the drain valve.

**NA5453 DIRTMAG®**



Dirt separator with magnet.  
Brass mounting housing.  
Composite PA66G30 body.  
Max. working pressure: 45 psi.  
Working temperature range: 32° – 195°F.  
Particle separation capacity: to 5 µm (0.2 mil).  
Ferrous impurities separation efficiency: 100%.  
Drain valve with hose connection.  
Top dosing point port.  
Dosing capacity: 12 fluid oz.  
Manual screw air vent.

Code	Description	Lbs	USD
<b>NA545305</b>	¾" NPT male union	4.5	<b>214.00</b>
<b>NA545365</b>	¾" press union	4.5	<b>233.00</b>
<b>NA545395</b>	¾" sweat union	4.5	<b>213.00</b>
<b>NA545306</b>	1" NPT male union	4.5	<b>247.00</b>
<b>NA545366</b>	1" press union	4.7	<b>278.00</b>
<b>NA545396</b>	1" sweat union	4.5	<b>236.00</b>
<b>NA545355</b>	¾" NPT female union, isolation valves	5.5	<b>258.00</b>
<b>NA545356</b>	1" NPT female union, isolation valves	5.5	<b>300.00</b>
<b>NA545376</b>	1" press union, isolation valves	5.5	<b>409.00</b>



The special coupling between the locking nut and the mounting base allows the DIRTMAG® dirt separator to be rotated for installation to either vertical or horizontal pipes, while maintaining the same operating performance.

**MAXIMUM FLOW RATE**

Size	¾"	1"
GPM	10	10
Cv w/ ball valve	9	9
Cv w/o ball valve	12	12

**MAGNETIC DIRT SEPARATORS**

Ferrous and non-ferrous impurities in hydronic systems can deposit onto heat exchanger surfaces and accumulate in pump cavities causing reduced thermal efficiency and premature wear. The small and often microscopic magnetic particles, called magnetite, form when iron or steel corrodes. Highly abrasive, the extremely fine particles are difficult to remove by traditional means. DIRTMAG® separators offer highly efficient separation of typical dirt as well as magnetite. The magnetite is captured by a concentrated magnetic field created by a stack of neodymium rare-earth magnets positioned inside a brass dry-well which is below the flow stream. Non-magnetic dirt particles are separated by colliding with an internal element in the flow stream, settling to the bottom. The deep collection chamber keeps the dirt from re-entering the flow stream.



To purge the debris, the flexible magnetic stack is removed from the brass dry-well and, even while the system is still running, the drain valve can be opened. Aided by the system pressure, the dirt and magnetite flushes out quickly and effectively. DIRTMAG magnetic dirt separators accomplish 2½ times the ferrous impurities removal performance of standard dirt separators, delivering up to 100% elimination efficiency.



MAXIMUM FLOW RATE						
Size	2"	2½"	3"	4"	5"	6"
GPM	89	150	227	355	816	904
Cv	88	176	211	328	520	842

MAXIMUM FLOW RATE				
Size	8"	10"	12"	14"
GPM	1,570	2,450	3,525	4,800
Cv	1,055	1,400	1,755	2,075



**5465M  
DIRTMAG®**

Magnetic dirt separator with one magnet assembly.  
Internal element epoxy resin coated, stainless steel and HDPE.  
Complete with drain valve (code NA39753).  
¾" NPT male top thread with brass cap.  
ANSI 150 flange connections.  
Max. working pressure: 150 psi.  
Vessel temperature range: 32°–270°F.  
Particle separation capacity: to 5 µm (0.2 mil).  
Ferrous impurities separation efficiency: 100%.

Code	Description	Lbs	USD
546550AM	2" ANSI flange	41	<b>2,492.00</b>
546560AM	2½" ANSI flange	41	<b>2,683.00</b>
546580AM	3" ANSI flange	58	<b>3,627.00</b>
546510AM	4" ANSI flange	58	<b>4,012.00</b>



**NA5465M  
DIRTMAG® ASME/CRN**

Magnetic dirt separator with three-magnet assembly.  
Epoxy resin coated steel body.  
Complete with drain valve (code NA39753).  
¾" NPT male top thread with brass cap.  
ANSI 150 flange connections.  
Max. working pressure: 150 psi.  
Vessel temperature range: 32°–270°F.  
Particle separation capacity: to 5 µm (0.2 mil).  
Ferrous impurities separation efficiency: 100%.  
ASME and CRN registered.

Code	Description	Lbs	USD
NA546550AM	2" ANSI flange ASME & CRN	41	<b>3,534.00</b>
NA546560AM	2½" ANSI flange ASME & CRN	41	<b>3,731.00</b>
NA546580AM	3" ANSI flange ASME & CRN	58	<b>4,921.00</b>
NA546510AM	4" ANSI flange ASME & CRN	58	<b>5,327.00</b>
NA546512AM	5" ANSI flange ASME & CRN	141	<b>7,733.00</b>
NA546515AM	6" ANSI flange ASME & CRN	151	<b>9,732.00</b>



**NA5465M  
DIRTMAG® ASME/CRN**

Magnetic dirt separator with three-magnets assembly.  
Epoxy resin coated steel body.  
Complete with drain valve (code NA59600).  
¾" NPT male top thread with brass cap.  
ANSI 150 flange connections.  
Max. working pressure: 150 psi.  
Vessel temperature range: 32°–270°F.  
Particle separation capacity: to 5 µm (0.2 mil).  
Ferrous impurities separation efficiency: 100%.  
ASME registered. CRN registered thru 12".  
Consult factory for 14".

Code	Description	Lbs	USD
NA546520AM	8" ANSI flange ASME & CRN	345	<b>21,152.00</b>
NA546525AM	10" ANSI flange ASME & CRN	630	<b>31,188.00</b>
NA546530AM	12" ANSI flange ASME & CRN	880	<b>38,003.00</b>
NA546535AM	14" ANSI flange ASME	1,010	<b>47,106.00</b>

**ACCESSORIES FOR AIR AND DIRT SEPARATORS**



Hygroscopic air vent cap fits DISCAL 551®, and DISCALDIRT® 546 Series, and MINICAL™ 502 Series.

Code	Description	Lbs	USD
<b>R59681</b>	Vent cap	0.1	<b>19.40</b>



Anti-suction air vent cap fits DISCAL® 551, DISCALDIRT® 546 Series and MINICAL™ 502 Series.

Code	Description	Lbs	USD
<b>562100</b>	Vent cap	0.1	<b>20.30</b>



Replacement air vent cap fits DISCAL® 551 and DISCALDIRT® 546 Series.

Code	Description	Lbs	USD
<b>R59119</b>	Vent cap	0.1	<b>12.90</b>



Replacement plastic cap fits MINICAL 5020 and 5021 Series.

Code	Description	Lbs	USD
<b>R56214</b>	Vent cap	0.1	<b>2.20</b>



Replacement plastic air vent cap fits 5026 and 5027 Series.

Code	Description	Lbs	USD
<b>R56142</b>	Vent cap	0.1	<b>2.10</b>



Magnetic/drywell assembly for DISCALDIRTMAG® and DIRTMAG® Pro.

Code	Description	Lbs	USD
<b>49684A</b>	Fit 2" and 2½"	3.0	<b>318.00</b>
<b>49685A</b>	Fit 3" to 6"	3.0	<b>459.00</b>
<b>F0000349</b>	Fit 8" to 14"	3.0	<b>600.00</b>



DIRTCAL® to DIRTMAG® Retrofit kit for ¾" to 2" 5462 brass DIRTCAL.

Code	Description	Lbs	USD
<b>F41661A</b>	Retrofit kit	2.0	<b>115.00</b>



Replacement clip-on magnets for DIRTMAG® Pro.

Code	Description	Lbs	USD
<b>R39949</b>	Magnetic band	0.2	<b>38.70</b>



Replacement air vent assembly fits DISCAL® brass 551 Series (except Compact and Rotating Collar version), brass 546, brass and steel 5461 Series and SEP4™ 5495 Series.

Code	Description	Lbs	USD
<b>59829</b>	Air vent assembly for brass DISCAL®	2.0	<b>126.00</b>



Replacement air vent assembly fits steel 551, NA551 steel DISCAL® and 546 steel Series DISCALDIRT® and DISCALDIRTMAG®.

Code	Description	Lbs	USD
<b>59756</b>	Air vent assembly for steel DISCAL®	3.0	<b>139.00</b>



Replacement cover and float subassembly. Vent cap sold separately.

Code	Description	Lbs	USD
<b>F39807</b>	Cover and float for brass DISCAL®	0.4	<b>60.90</b>
<b>F0001470</b>	Cover and float for steel DISCAL®	0.5	<b>73.50</b>



Drain ball valve. Fits DIRTCAL® 5465 and NA5465 Series. Fits steel separators in section 2. Max. working pressure: 150 psi. Max. working temperature: 365°F.

Code	Description	Lbs	USD
<b>NA39753</b>	1" FNPT with lever	0.7	<b>43.90</b>
<b>NA59600</b>	2" FNPT with lever	3.5	<b>156.00</b>



Vent cap adapter fits all air separators and air vents except 5026 and 5027 Series.

Code	Description	Lbs	USD
<b>NA10204</b>	¼" MNPT	0.1	<b>22.00</b>



Replacement coalescing element for brass separators (except 551 Compact and 5517 Rotating collar).

Code	Description	Lbs	USD
<b>F0001179</b>	For sizes ¾" to 1¼" (sweat)	0.2	<b>20.30</b>
<b>F59917</b>	For sizes 1¼" (NPT, press) to 2"	0.2	<b>20.30</b>



Replacement GHT cap for DIRTMAG® (shown attached to 538 drain valve, not included).

Code	Description	Lbs	USD
<b>R49418</b>	cap with teather	0.1	<b>17.50</b>

**AUTOMATIC AND MANUAL AIR VENTS**



**5026 ROBOCAL™**

Automatic air vent.  
Brass body.  
Max. working pressure: 150 psi.  
Max. discharge pressure: 90 psi.

Code	Description	Lbs	USD
502610A	1/8" MNPT	0.6	15.50
502620A	1/4" MNPT	0.6	16.40
502420	1/4" straight thread	1.0	21.60
502630	3/8" straight thread	1.0	21.60
502640	1/2" straight thread	1.0	23.40



**5027 ROBOCAL™**

Automatic air vent with service check valve.  
Brass body.  
Max. working pressure: 150 psi.  
Max. discharge pressure: 90 psi.

Code	Description	Lbs	USD
502710A	1/8" MNPT	0.6	21.50
502720A	1/4" MNPT	0.6	22.80



**NA5027 ROBOCAL™**

Automatic air vent with service check valve.  
Brass body.  
Max. working pressure: 150 psi.  
Max. discharge pressure: 90 psi.

Code	Description	Lbs	USD
NA502740A	1/2" MNPT, hygroscopic anti-drip cap	0.6	29.60

**MINICAL™ and VALCAL™**

These float type automatic air vents are designed to vent released air from the water while being heated. They are used on manifolds or pipes in sealed heating systems.

MINICAL is a standard size air vent that will discharge up to 1.75 SCFM.

VALCAL is a high capacity larger size air vent that will discharge up to 2.5 SCFM.

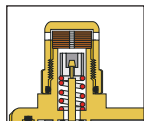
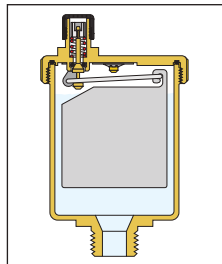

Some MINICAL and VALCAL models are equipped with a hygroscopic safety cap. Cellulose fiber discs in the cap serve as a redundant seal. Their volume increases by 50% when wet, sealing the discharge vent.

Some MINICAL and VALCAL models are equipped with a service check valve which facilitates maintenance operations by shutting off the water flow when the air vent is removed and also allows an easy replacement of the air vent without purging the system.

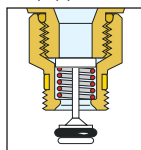

**5020 MINICAL™**

Automatic air vent.  
Brass body.  
Max. working pressure: 150 psi.  
Max. discharge pressure: 32 psi.  
Max. discharge rate: 1.75 SCFM.  
Max. working temperature: 250°F.

Code	Description	Lbs	USD
502015A	1/8" MNPT	0.4	17.40
502040A	1/2" MNPT	0.4	17.40



**5021 MINICAL™**

Automatic air vent with service check valve.  
Brass body.  
Max. working pressure: 150 psi.  
Max. discharge pressure: 32 psi.  
Max. discharge rate: 1.75 SCFM.  
Max. working temperature: 230°F.

Code	Description	Lbs	USD
502115A	1/8" MNPT	0.4	23.40
502113A	1/8" MNPT, hygroscopic anti-drip cap	0.4	26.90



**5020 MINICAL™**

Automatic air vent.  
Brass body.  
Hygroscopic safety air vent cap.  
Max. working pressure: 150 psi.  
Max discharge pressure: 32 psi.  
Max. discharge rate: 1.75 SCFM.  
Max. working temperature: 250°F.

Code	Description	Lbs	USD
502043A	1/2" MNPT	0.6	24.50



**5022 VALCAL™**

High discharge automatic air vent.  
Hygroscopic safety air vent cap.  
Max. working pressure: 150 psi.  
Max. discharge pressure: 60 psi.  
Max. discharge rate: 2.5 SCFM.  
Max. working temperature: 250°F.

Code	Description	Lbs	USD
502243A	1/2" MNPT	0.5	41.90



**5023 VALCAL™**

High discharge vent with service check.  
Hygroscopic safety air vent cap.  
Max. working pressure: 150 psi.  
Max. discharge pressure: 60 psi.  
Max. discharge rate: 2.5 SCFM.  
Max. working temperature: 230°F.

Code	Description	Lbs	USD
502343A	1/2" MNPT	0.5	49.60

**AUTOMATIC AND MANUAL AIR VENTS**

**MAXCAL™**

Extra high capacity air vent is ideal for use in large piping systems and can also be installed in horizontal piping. The valve body and cover are made of forged brass while the filter, valve stem, float, and spring are all made of stainless steel to prevent the formation of rust.

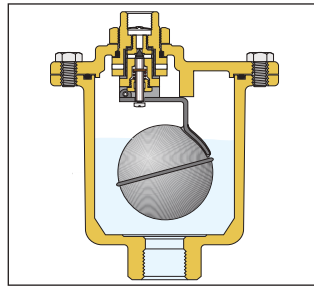

**501  
MAXCAL™**

Automatic air vent for heating and air conditioning. Brass body and cover, stainless steel internal components. Extra high discharge capacity. Max. working pressure: 230 psi. Max. discharge pressure: 90 psi. Max. discharge rate: 9 SCFM. Working temperature range: -4° — 250°F. Discharge top thread: 3/8" female.

Code	Description	Lbs	USD
501502A	3/4" FNPT	7.0	<b>324.00</b>

**551  
DISCALAIR®**

High discharge automatic air vent. Brass body. Stainless steel float guide pin and linkage. Max. working pressure: 150 psi. Max. discharge pressure: 150 psi. Max. discharge rate: 4.5 SCFM. Max. working temperature: 230°F.



Code	Description	Lbs	USD
551004A	1/2" FNPT and 3/4" MNPT	0.8	<b>100.00</b>

**Function**

DISCALAIR® automatic air vents release air that forms in the hydraulic circuits of heating and air conditioning systems with pressures to 150 psi. The venting air discharge capacity is capable of expelling over 4 standard cubic feet per minute (SCFM). The circulation of fully de-aerated water or glycol-water mediums enables the equipment to operate under optimum conditions, free from noise, corrosion, localized overheating, or mechanical damage.

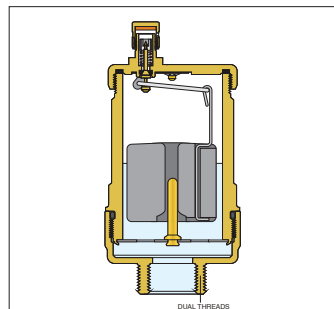

**5080  
HYGROCAL™**

Automatic hygroscopic air vent for hydronic heating system and low pressure steam. Manual operation by rotating knob. Chrome plated brass body. Max. working pressure: 150 psi. Max. working temperature: 212°F. Low pressure steam: 15 psi. **(Priced each, sold in quantities of 25)**

Code	Description	Lbs	USD
508013A	1/8" MNPT	0.1	<b>8.30</b>

Automatic radiator air vent valve is designed to remove any air trapped inside the heat emitters both during the filling of the system and in normal operation. The automatic air discharge happens when the hygroscopic cellulose fiber discs are dry. As air is vented and water contacts the hygroscopic discs, they increase their volume by 50% which causes the discharge vent to close.

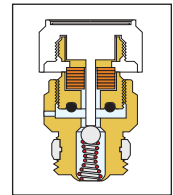

**5081**

Replacement hygroscopic cartridge fits hygroscopic air vent 5080 Series. **(Priced each, sold in quantities of 25)**

Code	Description	Lbs	USD
508100A	Cartridge	0.1	<b>7.30</b>



**337**

Manual air vent with metal seal and adjustable outlet. Brass body. Max. working pressure: 150 psi. Max. working temperature: 212°F.

Code	Description	Lbs	USD
337221A	1/4" MNPT	0.1	<b>10.50</b>



Service check valve for removal of air vent or expansion tank without purging system. Fits automatic air vents 502 Series. Max. working pressure: 150 psi. Max. working temperature: 230°F.

Code	Description	Lbs	USD
59474A	1/8" MNPT x FNPT	0.1	<b>12.80</b>
59804A	1/4" MNPT x FNPT	0.1	<b>13.50</b>
561402A	1/2" MNPT x FNPT	0.2	<b>15.60</b>

# JOURNAL SERIES EXCELLENCE IN EDUCATION



*idronics*



*idronics*<sup>TM</sup> is a complimentary educational journal series for hydronic, plumbing and renewable energy professionals to aid them in system design, component application and selection. The popular and frequently referenced publication is written by engineers and oriented towards innovative design techniques with a commitment to continuous education of North American professionals. Committed to Excellence in Education. **CALEFFI GUARANTEED.**

# THERMOSTATIC RADIATOR VALVES

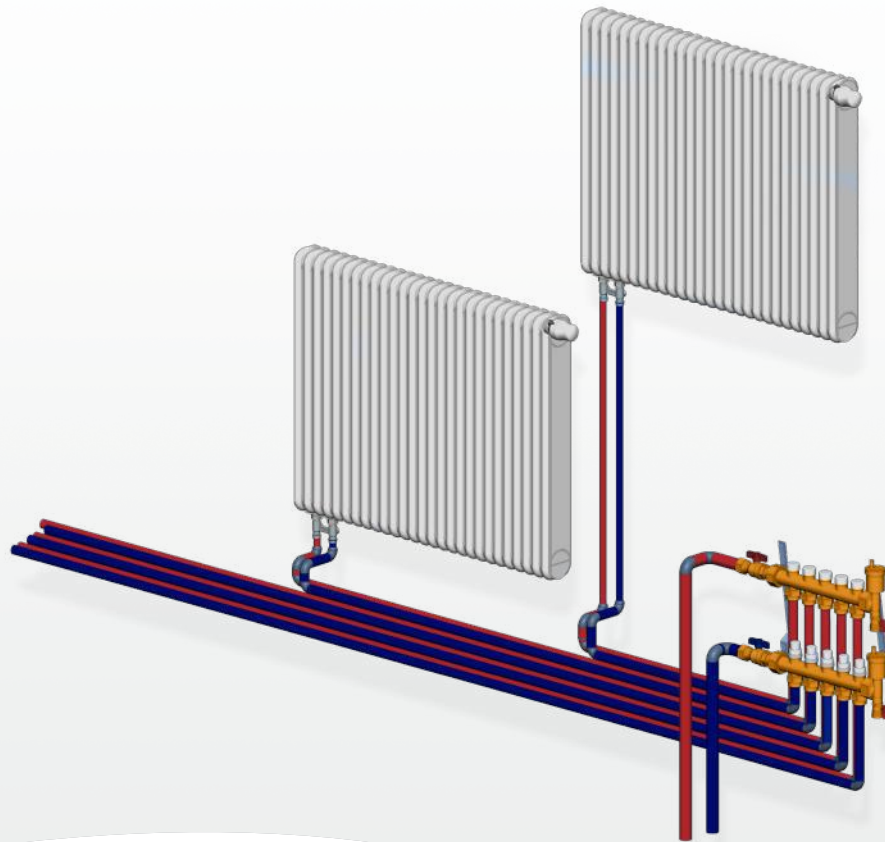

This diagram is for illustration purposes only



 **BIM**  
bim.caleffi.com

## PRODUCTS INCLUDED IN SECTION

- Thermostatic control heads
- Accessories for thermostatic control heads
- Thermo-electric actuator
- NPT thermostatic radiator valve bodies
- European style towel warmer radiator valves
- Connection valves for panel radiator
- Connection fittings
- Thermo-electric radiator valve bodies

**THERMOSTATIC CONTROL HEADS**



**200**

Thermostatic control head fits radiator valves. Set point locking mechanism. Range stop adjustment. Built-in sensor with liquid-filled element. Fits valve 220, 221, 338 and 339 Series. Graduated scale from \* to 5 corresponding to a temperature scale adjustment range of 45°–82°F (7°–28°C).

Code	Description	Lbs	USD
<b>200000</b>	Built-in sensor	0.5	<b>60.20</b>



**201**

Thermostatic control head fits radiator valves. With remote sensor. Fits valve 220, 221, 338 and 339 Series. Graduated scale from \* to 5 corresponding to a temperature scale adjustment range of 45°–82°F (7°–28°C). Capillary length: 78" (2 m).

Code	Description	Lbs	USD
<b>201000</b>	Remote sensor	1.0	<b>107.00</b>



**472**

Thermostatic control head with remote adjusting knob, liquid-filled element. Fits valves 220, 221, 338, 339 & 676 Series (direct coupling). Temperature range: 43°–82°F (6°–28°C). Capillary length: 78" (2 m).

Code	Description	Lbs	USD
<b>472000</b>	Remote wall sensor	1.0	<b>204.00</b>



**203**

Thermostatic control head fits radiator valves; with contact probe. Built-in sensor with liquid-filled element. Fits valve 220, 221, 338 and 339 Series. The pre-set scale corresponds to adjustment temperature range of 68°–122°F (20°–50°C). Capillary length: 78" (2 m).

Code	Description	Lbs	USD
<b>203502</b>	Remote sensor probe	0.5	<b>203.00</b>

**ACCESSORIES**



**4490**

Manual knob for thermostatic radiator valves. Fits valves 220 and 221 Series.

Code	Description	Lbs	USD
<b>449010</b>	Manual knob	0.1	<b>12.60</b>

**THERMO-ELECTRIC ACTUATOR**



**6564**

Thermo-electric actuator for electric control of radiator valves. Fits valves 220, 221, 338 and 339 Series. Low current draw. Power supply: 24 V AC/DC. Initial current draw: ≤ 250 mA. Power consumption: 3 W, 6 VA. 31.5" wire lead connection.

Code	Description	Lbs	USD
<b>656404</b>	24 V AC/DC	0.4	<b>82.80</b>
<b>656414</b>	24 V AC/DC with microswitch	0.4	<b>105.00</b>

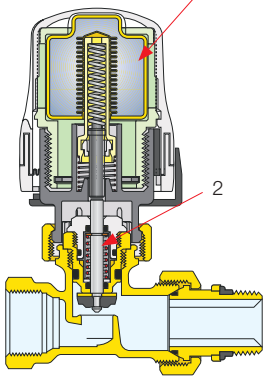

**Key features**

The thermostatic control head is filled with a non-compressible liquid bellows (1). Plus, the radiator valve body has an extra strong valve stem compression spring (2). The non compressible liquid provides the force required to compress the strong valve stem spring. When the temperature decreases, the liquid bellows contracts, which allows the valve stem spring to lift the valve plug from valve seat after long periods of non-movement. This ensures that after a long off-season, when the actuator operates for the first time, the spring reliably lifts the valve plug off the seat without sticking. In addition, the 200000 control head features an easy-to-use locking mechanism that prevents unauthorized temperature set point changes and a range stop adjustment that limits the maximum temperature setting to save energy and over-heating.

**Function**

The control mechanism of the thermostatic radiator valve is a proportional temperature controller, composed of a liquid filled bellows. With increasing temperature the liquid expands which, causes the bellows to expand. When the temperature decreases the opposite occurs; the bellows contract allowing the spring to return it to the original position. By connection to the valve stem, these movements adjust the heat transfer medium to the radiator.

\*Head shown vertical for illustration only, it should be installed horizontally.

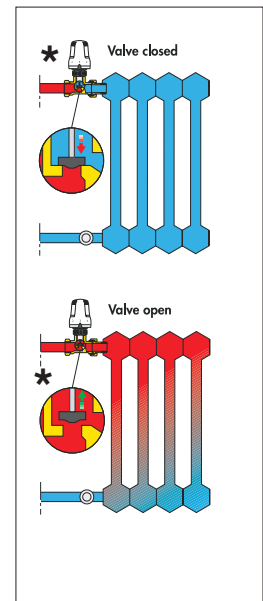



**NPT THERMOSTATIC RADIATOR VALVE BODIES**

**220**



Angled radiator valve body. Order thermo-electric actuators or thermostatic control heads separately for field installation.  
Chrome plated.  
Max. working pressure: 150 psi (10 bar).  
Temperature range: 40°–212°F (5°–100°C).

Code	Description	Cv	Lbs	USD
<b>220400A</b>	½" FNPT in, ½" NPT male union out	2.7	0.3	<b>59.00</b>
<b>220500A</b>	¾" FNPT in, ¾" NPT male union out	3.7	0.3	<b>64.60</b>

**221**



Straight radiator valve body. Order thermo-electric actuators or thermostatic control heads separately for field installation.  
Chrome plated.  
Max. working pressure: 150 psi (10 bar).  
Temperature range: 40°–212°F (5°–100°C).

Code	Description	Cv	Lbs	USD
<b>221400A</b>	½" FNPT in, ½" NPT male union out	1.7	0.3	<b>59.00</b>
<b>221500A</b>	¾" FNPT in, ¾" NPT male union out	2.5	0.3	<b>64.60</b>

Replacement internal valve assembly fits radiator valves.



Code	Description	Lbs	USD
<b>F36073</b>	½" and ¾"	0.1	<b>8.20</b>

Universal radiator tool for installing ½ and ¾" tail pieces.



Code	Description	Lbs	USD
<b>387127</b>	Radiator tool	1.0	<b>86.50</b>

**EUROPEAN STYLE TOWEL WARMER RADIATOR VALVES**

**338**



Angled radiator valve body. Convertible from standard manual operation to automatic control with thermostatic control heads.  
Chrome plated.  
Fits copper, single and multilayer PEX pipes.  
Max. working pressure: 150 psi (10 bar).  
Temperature range: 40°–212°F (5°–100°C).

Code	Radiator Connection	Pipe Connection	Cv	Lbs	USD
<b>338452</b>	½" straight	¾" conical	3.1	0.5	<b>62.10</b>

**342**



Angled isolation and balancing valve. Chrome plated.  
Fits copper, single and multilayer PEX pipes.  
Max. working pressure: 150 psi (10 bar).  
Temperature range: 40°–212°F (5°–100°C).

Code	Radiator Connection	Pipe Connection	Cv	Lbs	USD
<b>342452</b>	½" straight	¾" conical	4.6	0.5	<b>40.80</b>

**339**



Straight radiator valve body. Convertible from standard manual operation to automatic control with thermostatic control heads.  
Chrome plated.  
Fits copper, single and multilayer PEX pipes.  
Max. working pressure: 150 psi (10 bar).  
Temperature range: 40°–212°F (5°–100°C).

Code	Radiator Connection	Pipe Connection	Cv	Lbs	USD
<b>339452</b>	½" straight	¾" conical	2.0	0.5	<b>67.00</b>

**343**



Straight isolation and balancing valve. Chrome plated.  
Fits copper, single and multilayer PEX pipes.  
Max. working pressure: 150 psi (10 bar).  
Temperature range: 40°–212°F (5°–100°C).

Code	Radiator Connection	Pipe Connection	Cv	Lbs	USD
<b>343452</b>	½" straight	¾" conical	2.5	0.5	<b>42.80</b>

Intended for use in metric radiators such as European towel warmers and panel radiators.

**CONNECTION VALVES FOR PANEL RADIATORS**

Caleffi panel radiator valves are designed to be connected to the bottom of panel radiators. They come in two versions: for two-pipe and one-pipe systems. Both are available straight (pipes exiting the floor) and angled (pipes exiting the wall). The two-pipe version is equipped with two ball shut-off valves. The one-pipe, in addition to the shut-off valves, is equipped with an adjustable by-pass which diverts from 30% to 50% of the flow rate towards the radiator, and a flow check valve device (1) prevents thermo-syphoning upward into radiator from by-passing flow.

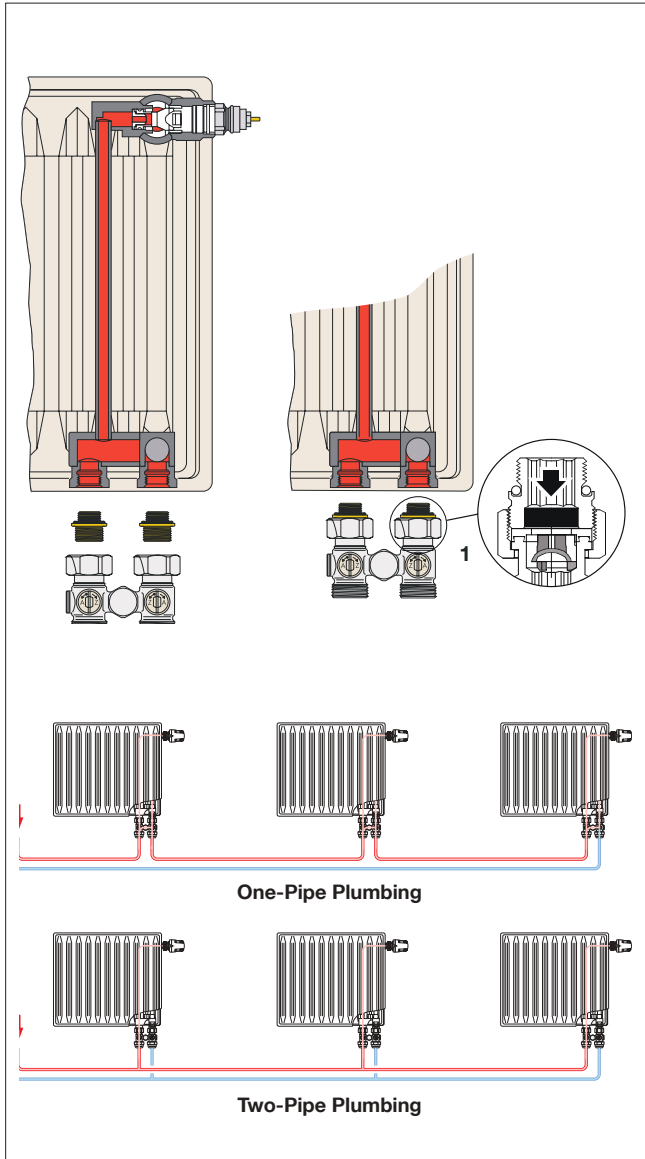

**3010**

Valve for panel radiators that have built-in thermostatic valve unit. Two-pipe straight version (floor connections) fits 1/2" female radiator connections. Max. working pressure: 150 psi (10 bar). Max. working temperature: 212°F (100°C).

Code	Radiator Connection	Pipe Connection	Lbs	USD
<b>301040</b>	1/2" straight	3/4" conical	1.0	<b>49.70</b>



**3011**

Valve for panel radiators that have built-in thermostatic valve unit. Two-pipe valve angled version (wall connections) fits 1/2" female radiator connections. Max. working pressure: 150 psi (10 bar). Max. working temperature: 212°F (100°C).

Code	Radiator Connection	Pipe Connection	Lbs	USD
<b>301140</b>	1/2" straight	3/4" conical	1.0	<b>49.70</b>



**3012**

Valve for panel radiators that have built-in thermostatic valve unit. One-pipe straight version (floor connections) fits 1/2" female radiator connections. With adjustable by-pass. Balance knob. Max. working pressure: 150 psi (10 bar). Max. working temperature: 212°F (100°C).

Code	Radiator Connection	Pipe Connection	Lbs	USD
<b>301241</b>	1/2" straight	3/4" conical	1.0	<b>87.00</b>



**3013**

Valve for panel radiators that have built-in thermostatic valve unit. One-pipe angled version (wall connections) fits 1/2" female radiator connections. With adjustable by-pass. Balance knob. Max. working pressure: 150 psi (10 bar). Max. working temperature: 212°F (100°C).

Code	Radiator Connection	Pipe Connection	Lbs	USD
<b>301341</b>	1/2" straight	3/4" conical	1.0	<b>87.00</b>



**4497**

Wall-covering plate. Fits dual panel radiator valves 301. With wall connections. In white ABS. Outlet center distance: 40—50 mm.

Code	Description	Lbs	USD
<b>449740</b>	Plate	0.1	<b>4.40</b>

CONNECTION FITTINGS



**681**  
**Universal PEX fittings**

681 Series fittings are compatible with any ASTM F876 single layer PEX. Max. working pressure: 150 psi. Working temperature for ASTM F876 PEX piping: 41° – 180°F. Chrome plated nut.

Code	Description	Lbs	USD
681503A	3/8" nominal PEX	0.2	10.60
681524	1/2" nominal PEX	0.2	10.60
681555	5/8" nominal PEX	0.2	10.40



**682**  
**Universal PEX-AL-PEX fittings**

682 Series fittings are compatible with any ASTM F1281 multilayer PEX-AL-PEX pipe. Max. working pressure: 150 psi. Working temperature for ASTM F1281 PEX-AL-PEX piping: 41° – 200°F with tubing rated 200°F.

Code	Description	Lbs	USD
682540A	1/2" PEX-AL-PEX	0.2	10.40

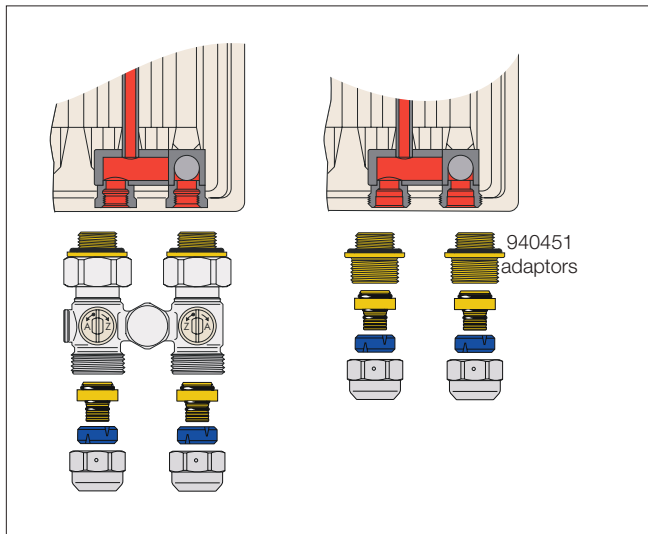

**940**



Radiator adapter for directly connecting a panel radiator with PEX, PEX-AL-PEX, sweat, NPT or compression fittings. **Package of 2 each**, priced per package.

Code	Description	Lbs	USD
940451	1/2" M straight x 3/4" M conical (2 ea.)	0.1	19.10



Wrench for tightening PEX fitting to TRV.

Code	Description	Lbs	USD
387100	26 mm x 30 mm	1.5	47.80



**437**

Compression fitting. Fits 1/2" hard copper. With o-ring seal. Max. working pressure: 150 psi. Working temperature range: 41° – 250°F. Chrome plated. For connecting copper to valve 301, 338, 339, 342 and 343 Series.

Code	Description	Lbs	USD
437516	1/2" compression	0.1	8.50



**NA102**

Sweat connection fitting. Fits 1/2" copper. Max. working pressure: 150 psi. Working temperature range: 41° – 250°F. Chrome plated nut. For connecting copper to valve 301, 338, 339, 342 and 343 Series.

Code	Description	Lbs	USD
NA10262	1/2" sweat	0.2	11.30



**NA103**

NPT connection fitting. Max. working pressure: 150 psi. Working temperature range: 41° – 250°F. Chrome plated nut. For connecting copper to valve 301, 338, 339, 342 and 343 Series.

Code	Description	Lbs	USD
NA10313	1/2" NPT male	0.2	12.20

## Z-ONE™ VALVES AND RELAYS ZONING DONE RIGHT



The reliable **Z-one™ Motorized Zone Valves** offer quick installation and easy service in a wide variety of commercial and residential applications including radiant, fan coils, chilled or hot water and low pressure steam applications. When installed with a **Z-one™ Relay Control**, featuring universal compatibility and versatility, both qualify for our industry exclusive five-year warranty. **CALEFFI GUARANTEED.**



# ZONE VALVES, ZONE CONTROLS AND COIL KITS

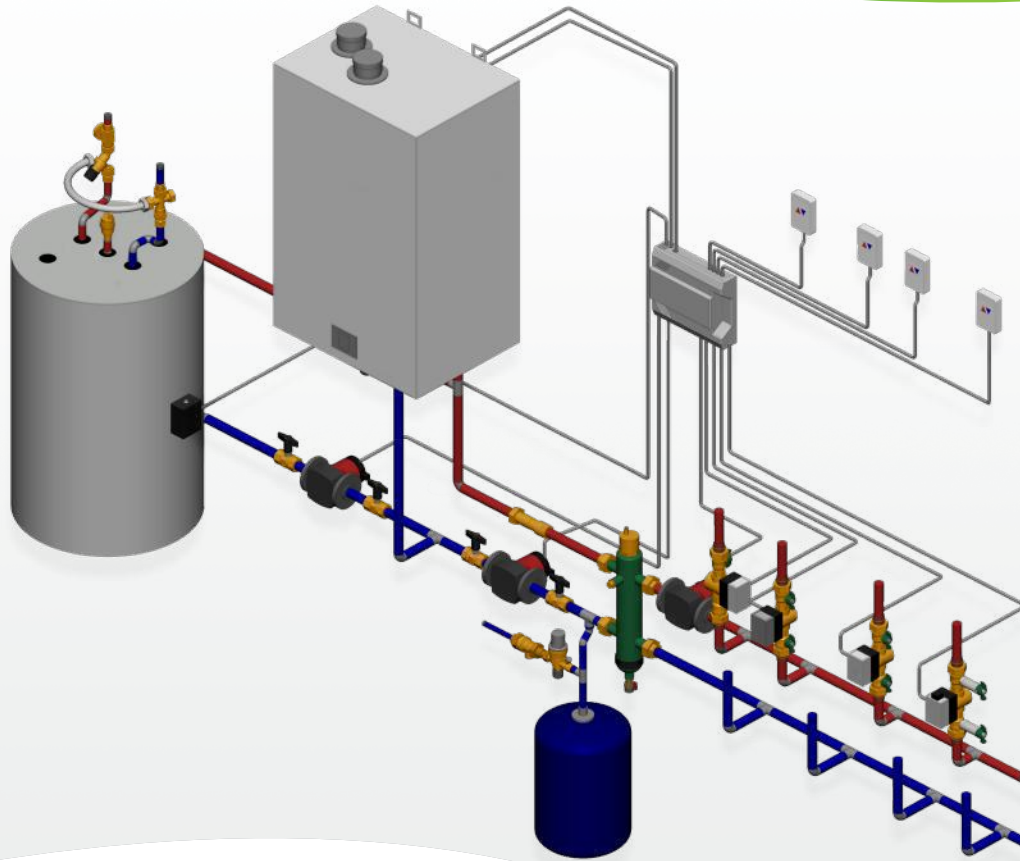

This diagram is for illustration purposes only



 **BIM**  
bim.caleffi.com

## PRODUCTS INCLUDED IN SECTION

Pressure independent control valves (PICV)

Coil kits

Thermo-electric zone valves

Motorized zone valves

Pump zone controls

Valve zone controls

Motorized ball zone valves, high-flow, high-close off

PRESSURE INDEPENDENT CONTROL VALVES (PICV)

2<sup>nd</sup> QTR



**145 FLOWMATIC® NPT**

Pressure independent control valve. Flow rate is adjusted in two different ways: - manually on the automatic flow rate regulator, to restrict the maximum value - automatically by the control valve in combination with a proportional (0-10 V) or ON/OFF actuator, in accordance with the thermal load requirements of the circuit being controlled.

Code	Description	GPM Range	Lbs	USD
145443A G90	1/2" FNPT	0.1 - 0.9	1.0	167.00
145443A 1G8	1/2" FNPT	0.4 - 1.8	1.0	167.00
145443A 3G5	1/2" FNPT	0.4 - 3.5	1.0	167.00
145553A G90	3/4" FNPT	0.1 - 0.9	1.0	178.00
145553A 1G8	3/4" FNPT	0.4 - 1.8	1.0	178.00
145553A 3G5	3/4" FNPT	0.4 - 3.5	1.0	178.00
145553A 5G3	3/4" FNPT	0.5 - 5.3	1.0	178.00
145663A 7G9	1" FNPT	0.8 - 7.9	1.1	322.00
145663A 13G	1" FNPT	1.3 - 13	1.1	322.00
145663A 16G	1" FNPT	1.6 - 16	1.1	344.00

2<sup>nd</sup> QTR



**145 FLOWMATIC® press**

Pressure independent control valve. Flow rate is adjusted in two different ways: - manually on the automatic flow rate regulator, to restrict the maximum value - automatically by the control valve in combination with a proportional (0-10 V) or ON/OFF actuator, in accordance with the thermal load requirements of the circuit being controlled.

Code	Description	GPM Range	Lbs	USD
145446A G90	1/2" press	0.1 - 0.9	1.0	178.00
145446A 1G8	1/2" press	0.4 - 1.8	1.0	178.00
145446A 3G5	1/2" press	0.4 - 3.5	1.0	178.00
145556A G90	3/4" press	0.1 - 0.9	1.0	189.00
145556A 1G8	3/4" press	0.4 - 1.8	1.0	189.00
145556A 3G5	3/4" press	0.4 - 3.5	1.0	189.00
145556A 5G3	3/4" press	0.5 - 5.3	1.0	189.00
145666A 7G9	1" press	0.8 - 7.9	1.1	333.00
145666A 13G	1" press	1.3 - 13	1.1	333.00
145666A 16G	1" press	1.6 - 16	1.1	367.00

2<sup>nd</sup> QTR



Pressure independent control valve actuator. Thermo-electric, 200 sec. stroke time

Code	Description	Lbs	USD
656524	24V, 0-10 V prop, NC	0.3	178.00

2<sup>nd</sup> QTR



Pressure independent control valve actuator. Thermo-electric, 200 sec. stroke time

Code	Description	Lbs	USD
656504	24V on/off, NC	0.3	100.00

2<sup>nd</sup> QTR



**145 FLOWMATIC® sweat**

Pressure independent control valve. Flow rate is adjusted in two different ways: - manually on the automatic flow rate regulator, to restrict the maximum value - automatically by the control valve in combination with a proportional (0-10 V) or ON/OFF actuator, in accordance with the thermal load requirements of the circuit being controlled.

Code	Description	GPM Range	Lbs	USD
145449A G90	1/2" sweat	0.1 - 0.9	1.0	156.00
145449A 1G8	1/2" sweat	0.4 - 1.8	1.0	156.00
145449A 3G5	1/2" sweat	0.4 - 3.5	1.0	156.00
145559A G90	3/4" sweat	0.1 - 0.9	1.0	167.00
145559A 1G8	3/4" sweat	0.4 - 1.8	1.0	167.00
145559A 3G5	3/4" sweat	0.4 - 3.5	1.0	167.00
145559A 5G3	3/4" sweat	0.5 - 5.3	1.0	167.00
145669A 7G9	1" sweat	0.8 - 7.9	1.1	311.00
145669A 13G	1" sweat	1.3 - 13	1.1	311.00
145669A 16G	1" sweat	1.6 - 16	1.1	356.00

Construction design

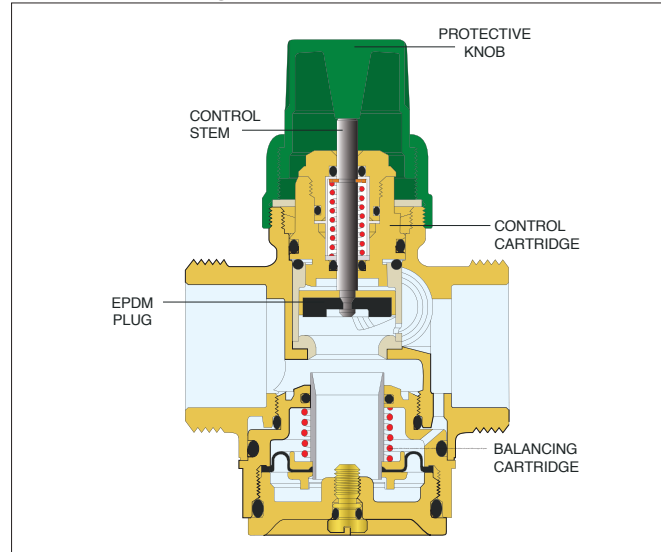

2<sup>nd</sup> QTR



**145 FLOWMATIC®**

Pressure independent control valve actuator. 24V, 0-10V proportional.

Code	Description	Lbs	USD
145013*	24V, 0-10V prop, fail-in-place	0.3	194.00
145018**	24V, 0-10 V prop., NC/NO	0.3	256.00

\* 145013 NC, fail in place

\*\* 145018 NC / NO, fail open or closed

COIL KITS

2<sup>nd</sup> QTR



**149 FLOWMATIC® Express Coil Kit**

Connection and regulation kit for HVAC terminal units. Dezincification resistant alloy body. Complete with:

- pressure independent control valve,
- three-way shut-off valves,
- integrated by-pass,
- Venturi device with pressure test ports.
- filtering cartridge,
- pre-formed insulation shell.

Max. working pressure: 360 psi.  
 Temperature range: 14° – 248°F.  
 Max. percentage of glycol: 50 %.  
 Δp range (PICV): 3.6 - 58 psi.  
 Compatible with 145 and 6565 Series actuators on page 38.

**Construction design**

The pre-assembled kit for terminal units is compact and enables control, balancing, testing and servicing the secondary circuit. It allows the connection of fan-coils, chilled beams or ceiling-mounted air-conditioning systems with the main distribution system. It also allows for maintenance and setting operations of the system. Complete with insulation suitable for both heating or cooling and venturi device for flow rate measurement at test ports.

Code	Description	GPM Range	Lbs	USD
149400A G40	½" NPT	0.1 - 0.4	5.0	400.00
149400A G90	½" NPT	0.4 - 0.9	5.0	400.00
149400A 1G8	½" NPT	0.9 - 1.8	5.0	400.00
149400A 3G5	½" NPT	1.8 - 3.5	5.0	400.00
149500A G90	¾" NPT	0.4 - 0.9	5.2	422.00
149500A 1G8	¾" NPT	0.9 - 1.8	5.2	422.00
149500A 3G5	¾" NPT	1.8 - 3.5	5.2	422.00
149500A 5G3	¾" NPT	3.5 - 5.3	5.2	422.00
149600A 7G9	1" NPT	5.3 - 7.9	6.3	500.00
149600A 13G	1" NPT	7.9 - 13	6.3	500.00
149600A 16G	1" NPT	8.0 - 16	6.3	500.00

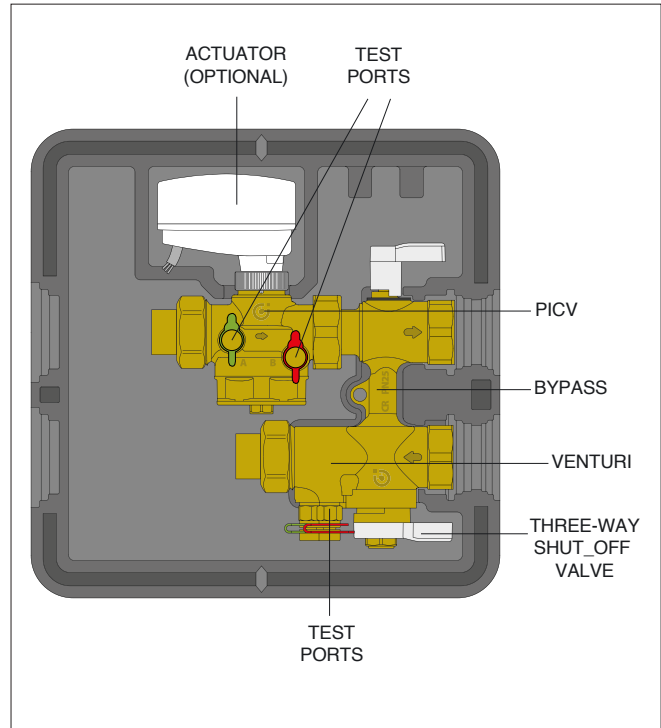

**Application Diagram**

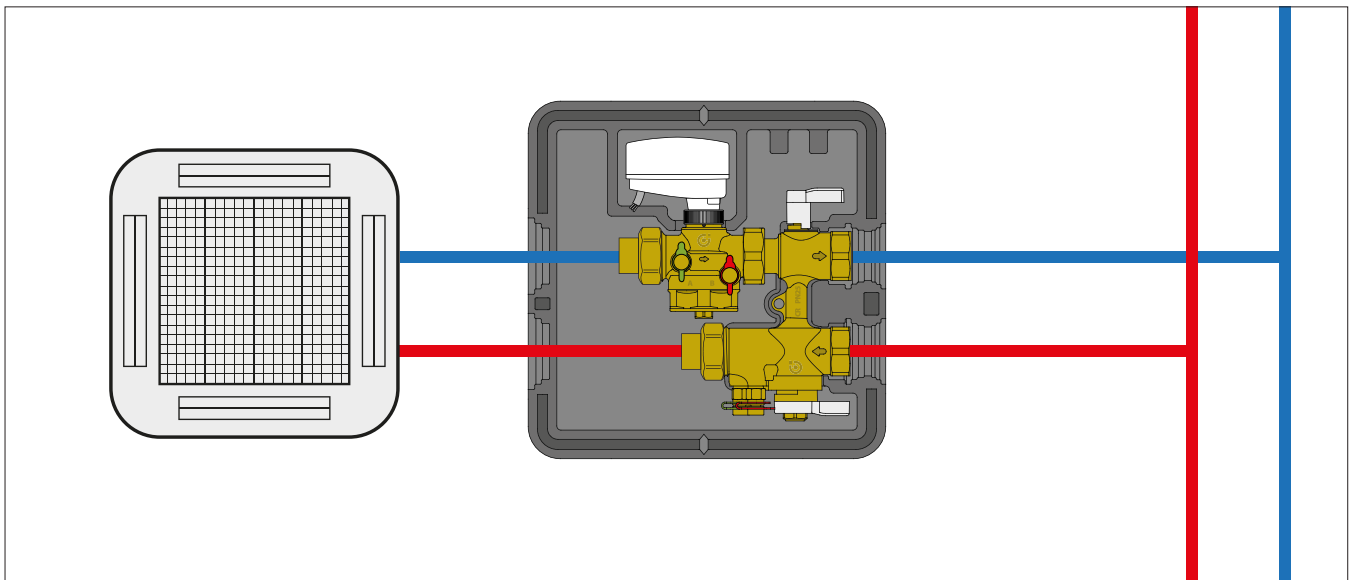

THERMO-ELECTRIC ZONE VALVES

**6767**  
**TwisTop+™ High Performance**



Complete with 656354 actuator.  
Pressure balanced body.  
40% more flow, 75% more close-off  
Spring return. Normally closed.  
Brass valve body and trim.  
Max. body pressure: 150 psi.  
Max. Temperature: 200°F.  
Power supply: 24 V AC/DC.  
Initial current draw: ≤ 250 mA.  
Power consumption:  
holding: 3 W  
inrush: 6 VA  
Rating of micro-switch contacts: 5 A (24 V).  
31½" wire lead connection.

**6762**  
**TwisTop™ Zone valve**



Two-way thermo-electric zone valve.  
Complete with TwisTop™ (code 656354)  
actuator. Spring return. Normally closed.  
Brass valve body and trim.  
Max. body pressure: 150 psi.  
Max. Temperature: 200°F.  
Power supply: 24 V AC/DC.  
Initial current draw: ≤ 250 mA.  
Power consumption:  
holding: 3 W  
inrush: 6 VA  
Rating of micro-switch contacts: 5 A (24 V).  
31.5" wire lead connection.

Code	Description	Cv	ΔP	Lbs	USD
676746A	½" press union <b>NEW</b>	5.6	35 psi	2.2	206.00
676749A	½" sweat union <b>NEW</b>	5.6	35 psi	2.2	224.00
676748A	½" PEX expansion union <b>NEW</b>	5.6	35 psi	2.2	224.00
676756A	¾" press union	5.6	35 psi	2.2	224.00
676759A	¾" sweat union	5.6	35 psi	2.2	217.00
676758A	¾" PEX expansion union	5.6	35 psi	2.2	217.00
676766A	1" press union	5.6	35 psi	2.2	254.00
676769A	1" sweat union	5.6	35 psi	2.2	243.00
676768A	1" PEX expansion union	5.6	35 psi	2.2	243.00
676500A	body only, close-off 35 psid	5.6	35 psi	1.0	55.90

Code	Description	Cv	ΔP	Lbs	USD
676246A	½" press union <b>NEW</b>	4.0	20 psi	1.4	187.00
676249A	½" sweat union <b>NEW</b>	4.0	20 psi	1.4	182.00
676248A	½" PEX expansion union <b>NEW</b>	4.0	20 psi	1.4	182.00
676256A	¾" press union	4.0	20 psi	1.4	204.00
676259A	¾" sweat union	4.0	20 psi	1.4	198.00
676258A	¾" PEX expansion union	4.0	20 psi	1.4	198.00
676266A	1" press union	4.0	20 psi	1.4	235.00
676269A	1" sweat union	4.0	20 psi	1.4	226.00
676268A	1" PEX expansion union	4.0	20 psi	1.4	226.00
676000A	body only, close-off 20 psid	4.3	20 psi	0.5	28.20

**6564**



Thermo-electric actuator fits on 676 two-way zone valve bodies.  
Low current draw.  
Protection class (installed in all positions): NEMA 3 (IP54)  
Power supply: 24 V AC/DC.  
Initial current draw: ≤ 250 mA.  
Power consumption:  
holding: 3 W  
inrush: 6 VA  
Rating of micro-switch contacts: 5 A (24 V).  
31.5" wire lead connection.

**6563**  
**TwisTop™**



TwisTop™ thermo-electric actuator fits on 676 two-way valve.  
Twist the top to manually open and close micro-switch.  
Power supply: 24 V AC/DC.  
Initial current draw: ≤ 250 mA.  
Power consumption:  
holding: 3 W  
inrush: 6 VA  
Rating of micro-switch contacts: 5 A (24 V).  
31.5" wire lead connection.  
U.S. Patent 7,617,989 B2.

Code	Description	Lbs	USD
656404	24 V AC/DC	0.4	82.80
656414	24 V AC/DC with micro-switch	0.4	105.00

Code	Description	Lbs	USD
656344	24 V AC/DC	0.4	111.00
656354	24 V AC/DC with micro-switch	0.4	131.00

Construction design

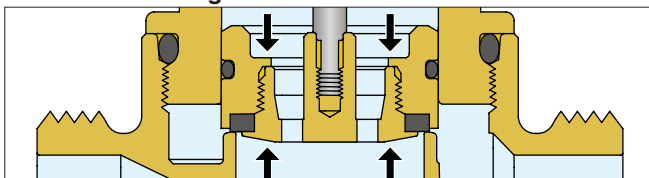

The pressure-balanced valve, code 676500A, has a special valve plug that can work at high differential pressures. As shown in the figure, the thrust towards the opening is counterbalanced by the force created by the pressure acting on the internal surface of the valve plug. This feature reduces the thrust needed to close the valve plug resulting in higher close-off pressure.



**MOTORIZED ZONE VALVES**



**Z4  
Zone 2-way**

Two-way zone valve. Spring return.  
Normally closed actuator: Z111000.  
Auxiliary micro-switch.  
Max. body pressure: 300 psi.  
Temperature range: 32°–240°F.  
Suitable fluids: water, 50% max. glycol,  
15 psi max. steam.  
Power supply: 24 V AC.  
Power consumption: 5 W, 7 VA.  
Rating of auxiliary micro-switch contacts:  
0.0 A min, 0.4 A max 24 V (24 V only).  
18" wire lead connection.  
UL873, cULus Listed & CE.  
UL 1995 sec. 18 air plenums and ducts.  
U.S. Patent 7,048,251.



**Z5  
Zone 2-way**

Two-way zone valve. Spring return.  
Normally closed actuator: Z151000.  
Auxiliary micro-switch.  
Max. body pressure: 300 psi.  
Temperature range: 32°–240°F.  
Suitable fluids: water, 50% max. glycol,  
15 psi max. steam.  
Power supply: 24 V AC.  
Power consumption: 5 W, 7 VA.  
Rating of auxiliary micro-switch contacts:  
0.0 A min, 0.4 A max 24 V (24 V only).  
Screw terminal connection.  
UL873, cULus Listed & CE.  
UL 1995 sec. 18 air plenums and ducts.  
U.S. Patent 7,048,251.



Code	Description	Cv	Δ P	Lbs	USD
<b>Z40</b>	Inverted flare	3.5	30 psi	2.2	<b>169.00</b>
<b>Z40F</b>	¾" Inv flare*	3.5	30 psi	2.2	<b>191.00</b>
<b>Z42</b>	½" SAE flare	3.5	30 psi	2.2	<b>182.00</b>
<b>Z44</b>	½" sweat	2.5	50 psi	2.1	<b>165.00</b>
<b>Z45</b>	¾" sweat	7.5	20 psi	2.2	<b>178.00</b>
<b>Z46</b>	1" sweat	7.5	20 psi	2.3	<b>222.00</b>
<b>Z47</b>	1¼" sweat	7.5	20 psi	2.3	<b>259.00</b>

\* Two ¾" sweat fittings (NA10006) included.

Code	Description	Cv	Δ P	Lbs	USD
<b>Z50</b>	Inverted flare	3.5	30 psi	2.2	<b>173.00</b>
<b>Z50F</b>	¾" Inv flare*	3.5	30 psi	2.2	<b>195.00</b>
<b>Z54</b>	½" sweat	2.5	50 psi	2.1	<b>169.00</b>
<b>Z55</b>	¾" sweat	7.5	20 psi	2.2	<b>182.00</b>
<b>Z56</b>	1" sweat	7.5	20 psi	2.3	<b>226.00</b>
<b>Z57</b>	1¼" sweat	7.5	20 psi	2.3	<b>263.00</b>

\* Two ¾" sweat fittings (NA10006) included.

**Zone 2-way Unions**



Two-way zone valve. Spring return.  
Auxiliary micro-switch.  
Max. body pressure: 300 psi.  
Overall length: 5-<sup>5</sup>/<sub>8</sub>"  
Temperature range: 32°–240°F.  
Suitable fluids: water, 50% max. glycol,  
15 psi max. steam.  
Power supply: 24 V AC.  
Power consumption: 5 W, 7 VA.  
Rating of auxiliary micro-switch contacts:  
0.0 A min, 0.4 A max 24 V (24 V only).  
UL873, cULus Listed & CE.  
UL 1995 sec. 18 air plenums and ducts.  
U.S. Patent 7,048,251.



Code	Description	Cv	Δ P	Lbs	USD
<b>Z44P</b>	½" press unions*	3.5	30 psi	2.2	<b>226.00</b>
<b>Z54P</b>	½" press unions**	3.5	30 psi	2.2	<b>230.00</b>
<b>Z45P</b>	¾" press unions*	7.5	20 psi	2.2	<b>230.00</b>
<b>Z55P</b>	¾" press unions**	7.5	20 psi	2.2	<b>234.00</b>
<b>Z45PL</b>	¾" press unions*	7.5	20 psi	2.3	<b>252.00</b>
<b>Z55PL</b>	¾" press unions**	7.5	20 psi	2.3	<b>256.00</b>
<b>Z46P</b>	1" press unions*	7.5	20 psi	2.4	<b>260.00</b>
<b>Z56P</b>	1" press unions**	7.5	20 psi	2.4	<b>265.00</b>
<b>Z55S</b>	¾" sweat unions	7.5	20 psi	2.2	<b>222.00</b>

\*18" wire lead connection.

\*\*Screw terminal connection.

PL (1) extra long press fitting for retrofit  
Includes press fittings.

**Construction design**

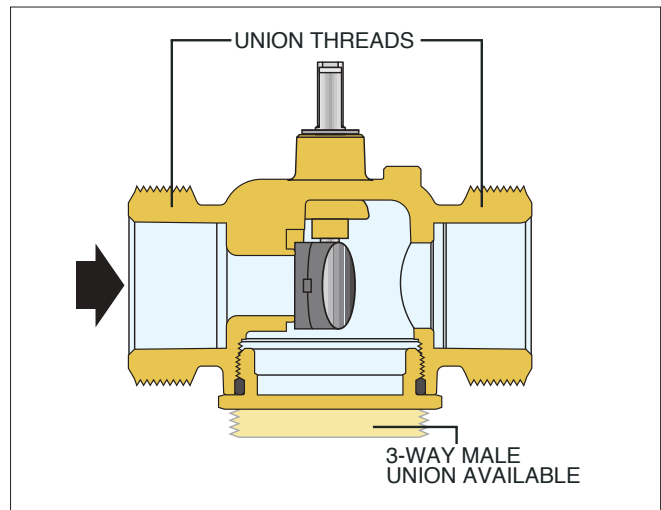

Inverted flare sweat adaptors fits Z40, Z50 and inverted flare valve body.

Code	Description	Lbs	USD
<b>NA10005</b>	½" sweat	0.3	<b>8.50</b>
<b>NA10006</b>	¾" sweat	0.3	<b>10.80</b>
<b>NA10007</b>	1" sweat	0.4	<b>17.90</b>
<b>NA61241</b>	Retrofit extension kit	0.2	<b>8.80</b>

MOTORIZED ZONE VALVES



Z1

Z1 Normally closed actuators fit on Z2 and Z3 valves. Normally open actuators fit on Z2 valves only. Easy pushbutton attachment 7/8" knockout for 1/2" conduit connector. Power: 24 and 120 VAC. Power consumption: 5 W, 7 VA. Conduit connector size: 1/2". Rating of auxiliary switch contacts: 24 VAC: 0.0 A min, 0.4 A max (24 V). 120 and Z111900 VAC: 0.25 A min, 5.0 A max (230 V). UL873, cULus Listed & CE. UL 1995 sec.18 air plenums and ducts. U.S. Patent 7,048,251.

Normally closed

Code	Description	Lbs	USD
Z111000	24 V, micro-switch, 18" wires	1.1	116.00
Z111900	24 V, high current switch, 18" wires	1.1	116.00
Z116000	120 V, micro-switch, 6" wires	1.1	116.00
Z151000	24 V, micro-switch, terminal blocks	1.1	121.00
Z161000	24 V, terminal blocks	1.1	110.00
Z121000	24 V, 18" wires	1.1	108.00
Z126000	120 V, 6" wires	1.1	108.00

Normally open

Code	Description	Lbs	USD
Z131000	24 V, micro-switch, 18" wires	1.1	128.00
Z136000	120 V, micro-switch, 6" wires	1.1	128.00
Z141000	24 V, 18" wires	1.1	117.00
Z146000	120 V, 6" wires	1.1	117.00

Function

The Z-one™ valve is a truly universal zone valve that can be used in a wide range of commercial and residential applications; from fan coils to baseboard, radiant to high rise, the Z-one is the professional's valve of choice. The Z-one can be used in both chilled or hot water and low pressure steam applications. With Delta P close off pressures of up to 75 PSI, the Z-one outperforms all other zone valves. The Z-one is available in sizes from 1/2" to 1 1/4" sweat or NPT connections on valve body, with removable actuator available in 24 to 120 voltages.

Some models of Z-one actuators contain an auxiliary micro-switch to operate other devices. The 24 V actuators use a sealed reed switch, which has been produced specifically for use with relays, boiler contacts (TT) and DDC systems. It requires no minimum current load. The 120 V actuators for applications requiring greater than 400 mA, use a conventional micro-switch with silver contacts. The auxiliary switch is activated when the valve is 60% open or when the actuator is manually opened.

• Manual opening (Normally closed actuator only)

The valve can be opened manually by moving the lever for opening it. When the power is restored the manual control is automatically overridden. The auxiliary switch in 24 V actuators is tripped when the unit is put into manual open position. This helps during start up to check if the wiring is correct without firing the valve electrically with the thermostat.

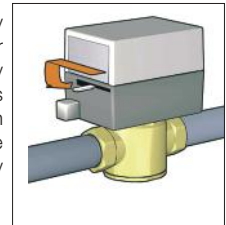

• Auxiliary micro-switch

The actuator contains an auxiliary microswitch to operate other devices. The 24 V actuators use a sealed reed switch, which has been produced specifically for use with relays, boiler contacts (TT) and DDC systems. It requires no minimum current load. The 120 V actuators use a conventional micro-switch with silver contacts. The auxiliary micro-switch is activated when the valve is 60% open or when the actuator is manually opened.

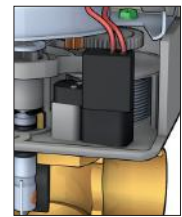

Construction details

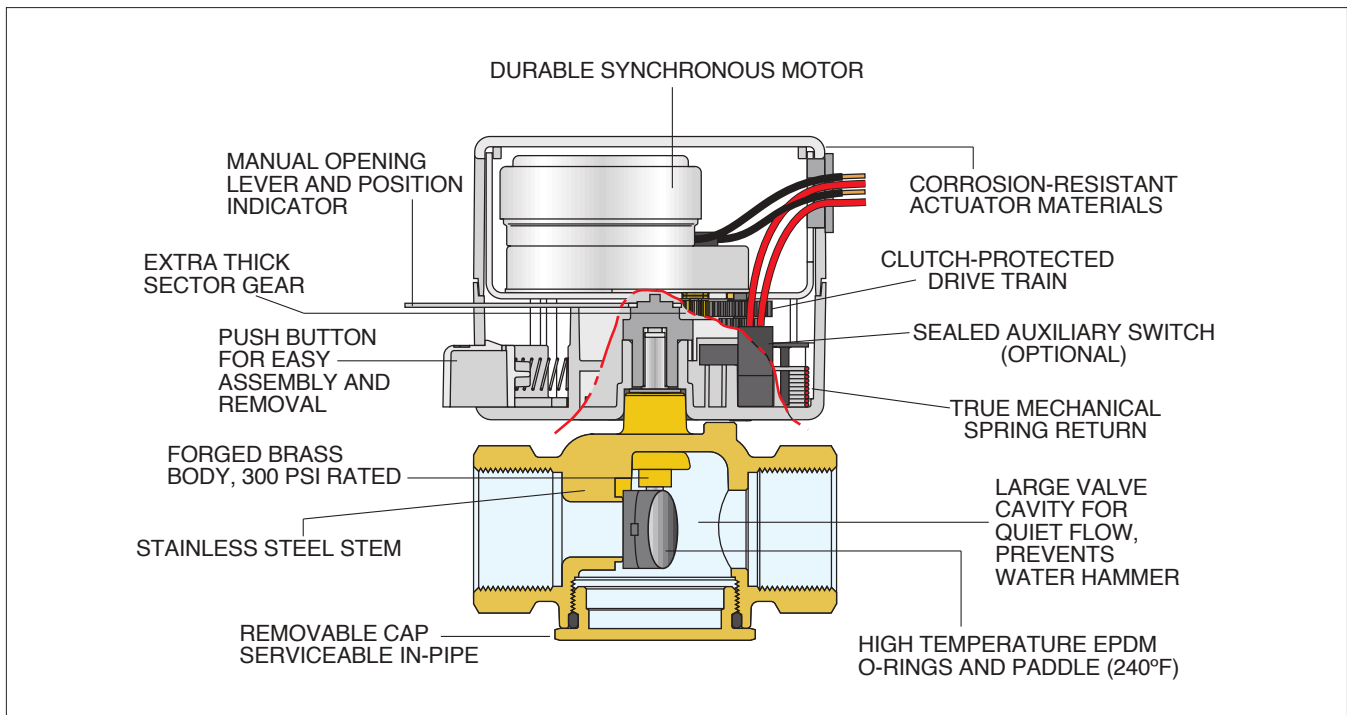

MOTORIZED ZONE VALVES

**Z2**  
**2-way**



Two-way on/off two position valve. Straight through flow pattern. Brass body. Stainless steel stem. EPDM rubber seals and paddle. Max. working pressure: 300 psi. Max temperature: 240°F.

**Z3**  
**3-way**



Three-way on/off two position valve. Diverting flow pattern. Brass body. Stainless steel stem. EPDM rubber seals and paddle. Max. working pressure: 300 psi. Max temperature: 240°F.

Code	Description	Cv	Δ P	Lbs	USD
Z200041	Inverted flare	1.0	75 psi	1.1	51.40
Z200042	Inverted flare	2.5	50 psi	1.1	51.40
Z200043	Inverted flare	3.5	30 psi	1.1	51.40
Z200053	½" SAE Flare	3.5	30 psi	1.1	65.80
Z200411	½" FNPT	1.0	75 psi	1.1	51.40
Z207411	½" FNPT <b>LL</b>	1.0	75 psi	1.1	70.10
Z200412	½" FNPT	2.5	50 psi	1.1	51.40
Z200413	½" FNPT	3.5	30 psi	1.1	51.40
Z200431	½" sweat	1.0	75 psi	1.0	47.10
Z200432	½" sweat	2.5	50 psi	1.0	47.10
Z207433	½" sweat <b>LL</b>	3.5	30 psi	1.0	65.80
Z200512	¾" FNPT	2.5	50 psi	1.2	70.10
Z200513	¾" FNPT	3.5	30 psi	1.2	70.10
Z200515	¾" FNPT	5.0	25 psi	1.2	70.10
Z200517	¾" FNPT	7.5	20 psi	1.2	70.10
Z200532	¾" sweat	2.5	50 psi	1.1	62.10
Z207533*	¾" sweat <b>LL</b>	3.5	30 psi	1.1	80.80
Z200535	¾" sweat	5.0	25 psi	1.1	62.10
Z200537	¾" sweat	7.5	20 psi	1.1	62.10
Z207537*	¾" sweat <b>LL</b>	7.5	20 psi	1.1	80.80
Z200617	1" FNPT	7.5	20 psi	1.3	111.00
Z200635	1" sweat	5.0	25 psi	1.2	105.00
Z200637	1" sweat	7.5	20 psi	1.2	105.00
Z200737	1¼" sweat	7.5	20 psi	1.3	141.00

**LL** Low-lead brass body.

Isolation ball valve. Low lead MxF union union fits between valve body and tailpiece.



Code	Description	Lbs	USD
290030	1" M x 1" F union ball valve	1.0	47.60
NA10815	Stem extension for 290030	0.2	27.10



Code	Description	Cv	Δ P	Lbs	USD
Z300053	½" SAE Flare	3.5	30 psi	1.1	82.20
Z300411	½" FNPT	1.0	75 psi	1.1	68.50
Z300412	½" FNPT	2.5	50 psi	1.1	68.50
Z300413	½" FNPT	3.5	30 psi	1.1	68.50
Z300431	½" sweat	1.0	75 psi	1.0	64.30
Z300432	½" sweat	2.5	50 psi	1.0	64.30
Z307433*	½" sweat <b>LL</b>	3.5	30 psi	1.0	82.80
Z300512	¾" FNPT	2.5	50 psi	1.2	85.60
Z300513	¾" FNPT	3.5	30 psi	1.2	85.60
Z300515	¾" FNPT	5.0	25 psi	1.2	85.60
Z300517	¾" FNPT	7.5	20 psi	1.2	85.60
Z300532	¾" sweat	2.5	50 psi	1.1	79.40
Z300533	¾" sweat	3.5	30 psi	1.1	79.40
Z300535	¾" sweat	5.0	25 psi	1.1	79.40
Z307537*	¾" sweat <b>LL</b>	7.5	20 psi	1.1	98.20
Z300617	1" FNPT	7.5	20 psi	1.3	129.00
Z300635	1" sweat	5.0	25 psi	1.2	119.00
Z300637	1" sweat	7.5	20 psi	1.2	119.00
Z300737	1¼" sweat	7.5	20 psi	1.3	145.00

\***LL** Low-lead brass body.

2-way male union valve body. Refer to fitting selection table in Section 8.



Code	Description	Cv	Δ P	Lbs	USD
Z200683	1" male union body	3.5	30 psi	1.1	70.10
Z200687	1" male union body	7.5	20 psi	1.1	70.10

3-way male union valve body. Refer to fitting selection table in Section 8.



Code	Description	Cv	Δ P	Lbs	USD
Z300687	1" male union body	7.5	20 psi	1.2	89.20

Two-way and three-way zone valve body repair kit. Includes valve stem paddle with O-rings, C clip and one bottom cap O-ring.



Code	Description	Lbs	USD
F69293	Fits all ½" & ¾" sweat Z2, Z3	0.4	17.70
F69294	Fits all ¾" NPT and all 1", 1¼" Z2, Z3	0.4	17.70

**PUMP ZONE CONTROLS**



 Certified to CSA C22-2 No.24  
 Conforms to UL Standard 873

**ZSR  
Z-one Relay**

The ZSR Series is multi-zone pump and boiler operating control for multiple zone hydronic heating systems. The ZSR Series interfaces with low voltage thermostats or any other low voltage controllers having a switching action. The ZSR Series controls up to 3, 4, 5 or 6 heating circulator pumps, depending on model selected, a primary pump, and has LED indicators to provide functional status and easy system troubleshooting. In addition, a primary pump system circulator is switched on whenever any zone calls for heat.

Power supply: 120 VAC, 50/60 Hz  
 Transformer voltage: 24 VAC  
 Maximum transformer load: 12 VA (ZSR101/103/104), 20 VA (ZSR106)  
 Electrical switch rating: 10A (ZSR101), 20A (ZSR103/4) max combined  
 Electrical switch rating pump output: 120 VAC, 5A each  
 Dry contact rating: AUX, XX, ZONE1 E/S: 120 VAC max, 2A each  
 Replaceable fuses: Type 2AG, 5A slow blow

**ZSR Z-ONE RELAY FUSES**

Code	Description	Lbs	USD
NA10342	Spare fuse (package of 5)	0.1	11.90

Code	Description	Lbs	USD
ZSR101	Single zone relay	1.0	117.00
ZSR103	3 zone pump control	2.0	278.00
ZSR104	4 zone pump control	2.0	325.00
ZSR106	6 zone pump control	2.0	398.00

**VALVE ZONE CONTROLS**



 Certified to CSA C22-2 No.24  
 Conforms to UL Standard 873

**ZVR  
Z-one Relay**

The ZVR Series is a multi-zone valve relay and boiler operating control for multiple zone hydronic heating systems. The ZVR Series interfaces with low voltage thermostats or any other low voltage controllers having a switching action. The ZVR Series controls up to 3, 4, 5 or 6 zones, depending on model selected. In addition, a system circulator pump and secondary pump is turned on whenever any zone calls for heat. LED indicators provide functional status and easy system troubleshooting. The ZVR Series is a perfect match with Caleffi's Z-one™ motorized zone valves.

Power supply: 120 VAC, 50/60 Hz  
 Transformer voltage: 24 VAC  
 Maximum transformer load: 40 VA (ZVR103/4), 80 VA (ZVR106)  
 Electrical switch rating: 20A Max Combined  
 Electrical switch rating pumps: 120 VAC, 5A each  
 Dry contact rating: AUX, XX, ZONE1 E/S:120 VAC, 2A each  
 Resettable Fuse: automatic  
 High Capacity 40 VA Transformer standard for 3 and 4 zone models-  
 expandable to 80 VA, and 80 VA for the 6 zone model

Code	Description	Lbs	USD
ZVR103	3 zone valve control	2.0	211.00
ZVR104	4 zone valve control	2.0	250.00
ZVR106	6 zone valve control	2.0	325.00
NA10343	Expansion transformer	0.1	68.20

**MOTORIZED BALL ZONE VALVES HIGH-FLOW, HIGH CLOSE-OFF**



**6442  
2-way Straight**

Two-way motorized ball zone valve. Straight.  
Max. ΔP close-off pressure: 150 psi.  
Temperature range: 20°–230°F.  
Power supply: 24 VAC.  
Power consumption: 4 VA.  
Rating of micro-switch contacts: 5 A (24 V).  
3-wire control.  
36" wire lead connection.

Code	Description	Cv	Lbs	USD
<b>644250A</b>	¾" NPT male union	13	2.3	<b>328.00</b>
<b>644256A</b>	¾" press union	13	2.4	<b>328.00</b>
<b>644259A</b>	¾" sweat union	13	2.3	<b>321.00</b>
<b>644260A</b>	1" NPT male union	13	2.3	<b>354.00</b>
<b>644266A</b>	1" press union	13	2.4	<b>357.00</b>
<b>644269A</b>	1" sweat union	13	2.3	<b>347.00</b>
<b>NA644200*</b>	body, with no fittings	13	1.0	<b>284.00</b>

\*See fitting selection table in Section 8.

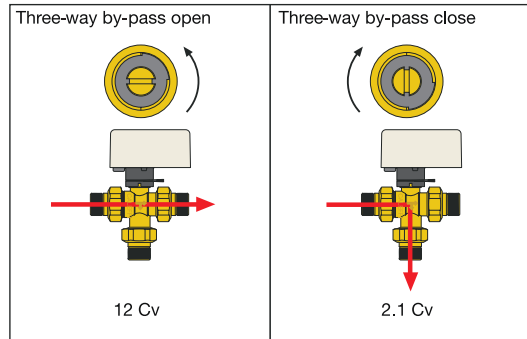
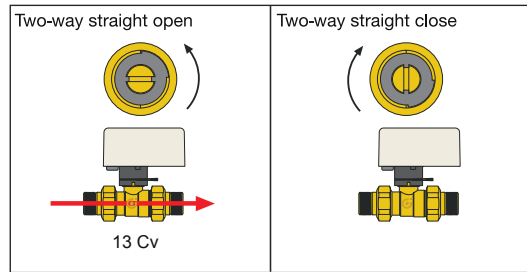

**6443..3BY  
3-way By-pass**



Three-way motorized ball zone valve. By-pass.  
Max. ΔP close-off pressure: 150 psi.  
Temperature range: 20°–230°F.  
Power supply: 24 VAC.  
Power consumption: 4 VA.  
Rating of micro-switch contacts: 5 A (24 V).  
3-wire control.  
2.1 Cv in by-pass mode.  
36" wire lead connection.

Code	Description	Cv	Lbs	USD
<b>644350A 3BY</b>	¾" NPT male union	12	2.5	<b>353.00</b>
<b>644356A 3BY</b>	¾" press union	12	2.6	<b>372.00</b>
<b>644359A 3BY</b>	¾" sweat union	12	2.5	<b>364.00</b>
<b>644360A 3BY</b>	1" NPT male union	12	2.5	<b>411.00</b>
<b>644366A 3BY</b>	1" press union	12	2.6	<b>417.00</b>
<b>644369A 3BY</b>	1" sweat union	12	2.5	<b>402.00</b>
<b>NA644300 3BY*</b>	body, no fittings	12	1.2	<b>308.00</b>

\*See fitting selection table in Section 8.

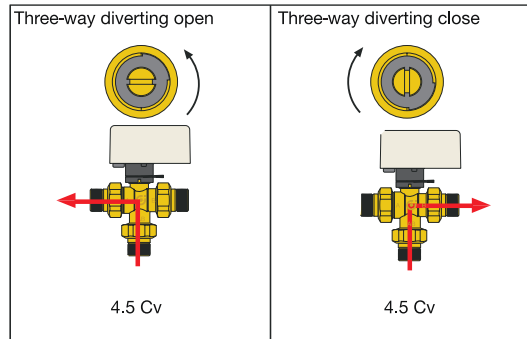

**6440  
24 V 3-wire control**



Actuator fits 6442 and 6443 Series.  
Power supply: 24 VAC.  
Power consumption: 4 VA.  
Rating of micro-switch contacts: 5 A (24 V).  
Operating time: 40 s (90° rotation).  
Length of supply cable: 36".

Code	Description	Lbs	USD
<b>644004</b>	24 VAC	1.0	<b>193.00</b>

**6443  
3-way Diverting**



Three-way motorized ball zone valve. Diverting.  
Max. ΔP close-off pressure: 150 psi.  
Temperature range: 20°–230°F.  
Power supply: 24 VAC.  
Power consumption: 4 VA.  
Rating of micro-switch contacts: 5 A (24 V).  
3-wire control.  
36" wire lead connection.

Code	Description	Cv	Lbs	USD
<b>644350A</b>	¾" NPT male union	4.5	2.5	<b>353.00</b>
<b>644356A</b>	¾" press union	4.5	2.6	<b>372.00</b>
<b>644359A</b>	¾" sweat union	4.5	2.5	<b>364.00</b>
<b>644360A</b>	1" NPT male union	4.5	2.5	<b>411.00</b>
<b>644366A</b>	1" press union	4.5	2.6	<b>417.00</b>
<b>644369A</b>	1" sweat union	4.5	2.5	<b>402.00</b>
<b>NA644300*</b>	body, no fittings	4.5	1.2	<b>308.00</b>

\*See fitting selection table in Section 8.

# WEBINAR SERIES EXCELLENCE IN EDUCATION



You are invited to join us for our monthly webinar Series, **Coffee with Caleffi™**. The complimentary technical training webinars are intended for contractors, designers, engineers, and wholesalers. A Certificate of Attendance is emailed to attendees following the webinar for continuing education consideration. Scan QR Code for webinar schedule. Missed a webinar? No problem! Our webinars are available 24/7 on YouTube for your convenience. Committed to Excellence in Education. **CALEFFI GUARANTEED.**

# DISTRIBUTION MANIFOLDS AND TEMPERATURE MIXING STATIONS

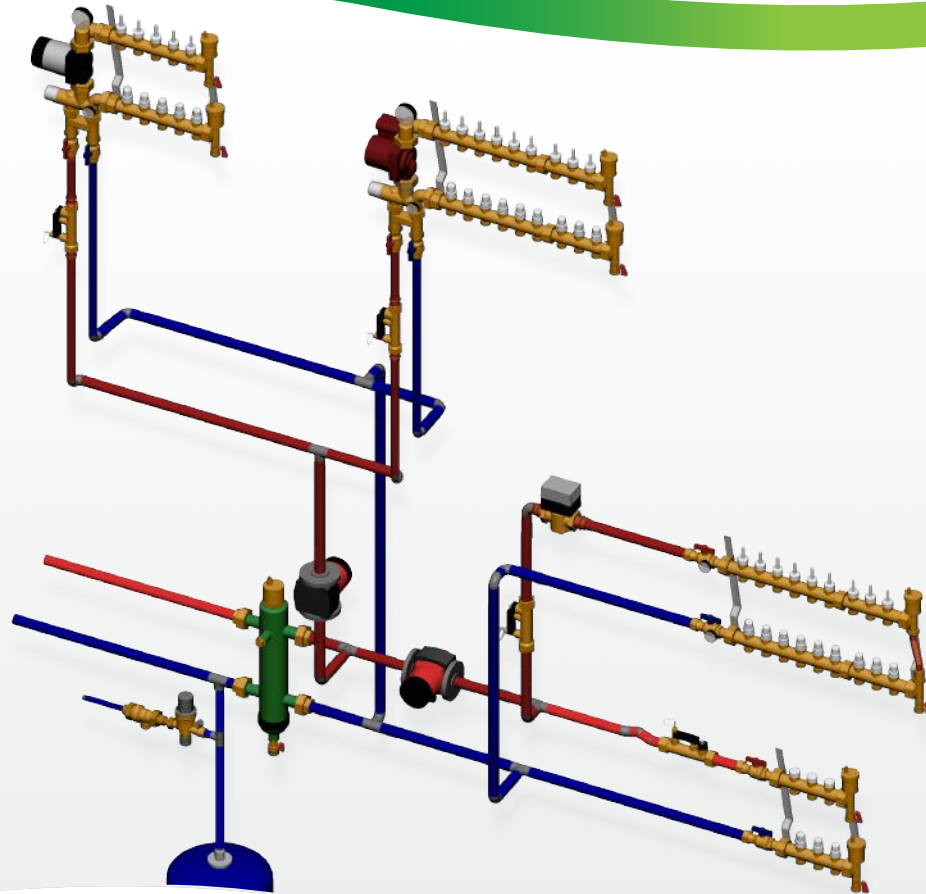

This diagram is for illustration purposes only



 **BIM**  
bim.caleffi.com

## PRODUCTS INCLUDED IN SECTION

- Thermostatic manifold mixing stations
- Low temperature manifold mixing stations
- Brass distribution manifolds
- Pump and valve temperature mixing units
- Fittings for distribution manifolds and mixing stations
- Boxes for distribution manifolds
- Thermo electric actuators for manifolds and valves

**THERMOSTATIC MANIFOLD MIXING STATIONS**

**172  
Low temperature manifold mixing station three speed pump**

Pre-assembled thermostatic manifold mixing station consisting of a supply distribution manifold complete with built-in sight flow gauges and adjustable balancing valves. Return manifold with built-in shutoff valves is suitable for thermo-electric actuators. Complete with built-in sensor to keep flow temperature at constant set value.

Includes Grundfos UPS 15–58 three-speed pump.

¾" F NPT supply/return ball valves.

Max. working pressure: 150 psi.

Control temperature range: 80°–130°F.

Primary inlet max. temperature: 195°F.

Outlet center distance: 2 in.

PT Gauge: (40°–240°F, 10°–110°C) (0-10 bar; 1-140 psi)

**Models with "...IN" suffix are built inverted (tubing connections going upward).**

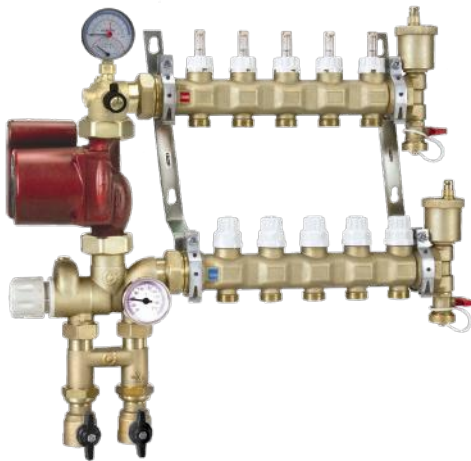

Code	Description	UPS Pump	No.	Outlets	Lbs	USD
1725C1A	¾"	15-58	3	¾" M	20	<b>1,272.00</b>
1725C1A IN	¾"	15-58	3	¾" M	20	<b>1,272.00</b>
1725D1A	¾"	15-58	4	¾" M	21	<b>1,355.00</b>
1725D1A IN	¾"	15-58	4	¾" M	21	<b>1,355.00</b>
1725E1A	¾"	15-58	5	¾" M	23	<b>1,436.00</b>
1725E1A IN	¾"	15-58	5	¾" M	23	<b>1,436.00</b>
1725F1A	¾"	15-58	6	¾" M	25	<b>1,519.00</b>
1725F1A IN	¾"	15-58	6	¾" M	25	<b>1,519.00</b>
1725G1A	¾"	15-58	7	¾" M	27	<b>1,602.00</b>
1725G1A IN	¾"	15-58	7	¾" M	27	<b>1,602.00</b>
1725H1A	¾"	15-58	8	¾" M	28	<b>1,684.00</b>
1725H1A IN	¾"	15-58	8	¾" M	28	<b>1,684.00</b>
1725I1A	¾"	15-58	9	¾" M	29	<b>1,765.00</b>
1725I1A IN	¾"	15-58	9	¾" M	29	<b>1,765.00</b>
1725L1A	¾"	15-58	10	¾" M	31	<b>1,846.00</b>
1725L1A IN	¾"	15-58	10	¾" M	31	<b>1,846.00</b>
1725M1A	¾"	15-58	11	¾" M	33	<b>1,928.00</b>
1725M1A IN	¾"	15-58	11	¾" M	33	<b>1,928.00</b>
1725N1A	¾"	15-58	12	¾" M	34	<b>2,012.00</b>
1725N1A IN	¾"	15-58	12	¾" M	34	<b>2,012.00</b>
1725O1A	¾"	15-58	13	¾" M	36	<b>2,093.00</b>
1725O1A IN	¾"	15-58	13	¾" M	36	<b>2,093.00</b>

**172  
Low temperature manifold mixing station high efficiency pump**

Pre-assembled thermostatic manifold mixing station consisting of a supply distribution manifold complete with built-in sight flow gauges and adjustable balancing valves. Return manifold with built-in shutoff valves is suitable for thermo-electric actuators. Complete with built-in sensor to keep flow temperature at constant set value.

Includes Grundfos Alpha 25-55U pump.

¾" F NPT supply/return ball valves.

Max. working pressure: 150 psi.

Control temperature range: 80°–130°F.

Primary inlet max. temperature: 195°F.

Outlet center distance: 2 in.

PT Gauge: (40°–240°F, 10°–110°C) (0-10 bar; 1-140 psi)

**Models with "...IN" suffix are built inverted (tubing connections going upward).**



Code	Description	Alpha Pump	No.	Outlets	Lbs	USD
1725C1AHE	¾"	25-55U	3	¾" M	20	<b>1,527.00</b>
1725C1AHE IN	¾"	25-55U	3	¾" M	20	<b>1,527.00</b>
1725D1AHE	¾"	25-55U	4	¾" M	21	<b>1,608.00</b>
1725D1AHE IN	¾"	25-55U	4	¾" M	21	<b>1,608.00</b>
1725E1AHE	¾"	25-55U	5	¾" M	23	<b>1,690.00</b>
1725E1AHE IN	¾"	25-55U	5	¾" M	23	<b>1,690.00</b>
1725F1AHE	¾"	25-55U	6	¾" M	25	<b>1,772.00</b>
1725F1AHE IN	¾"	25-55U	6	¾" M	25	<b>1,772.00</b>
1725G1AHE	¾"	25-55U	7	¾" M	27	<b>1,856.00</b>
1725G1AHE IN	¾"	25-55U	7	¾" M	27	<b>1,856.00</b>
1725H1AHE	¾"	25-55U	8	¾" M	28	<b>1,936.00</b>
1725H1AHE IN	¾"	25-55U	8	¾" M	28	<b>1,936.00</b>
1725I1AHE	¾"	25-55U	9	¾" M	29	<b>2,019.00</b>
1725I1AHE IN	¾"	25-55U	9	¾" M	29	<b>2,019.00</b>
1725L1AHE	¾"	25-55U	10	¾" M	31	<b>2,102.00</b>
1725L1AHE IN	¾"	25-55U	10	¾" M	31	<b>2,102.00</b>
1725M1AHE	¾"	25-55U	11	¾" M	33	<b>2,184.00</b>
1725M1AHE IN	¾"	25-55U	11	¾" M	33	<b>2,184.00</b>
1725N1AHE	¾"	25-55U	12	¾" M	34	<b>2,266.00</b>
1725N1AHE IN	¾"	25-55U	12	¾" M	34	<b>2,266.00</b>
1725O1AHE	¾"	25-55U	13	¾" M	36	<b>2,347.00</b>
1725O1AHE IN	¾"	25-55U	13	¾" M	36	<b>2,347.00</b>



## THERMOSTATIC MANIFOLD MIXING STATIONS

### Characteristic components / hydraulic diagram

Item	Description	Symbol
1	Circulation pump UPS 15-58 pictured	
2	Top elbow with supply temperature and pressure gauge	
3	Purge valve	
4	Supply temperature and pressure gauge	
5	Return temperature gauge	
6	Primary circuit shut-off valves	
7	Primary circuit hydraulic separator with check valve	
8	Thermostatic three-way mixing valve with built-in sensor	

Supply manifold equipped with flow meters and balancing valves.

Return manifold equipped with shut-off valves.

End fittings with automatic air vent with hygroscopic cap and drain cock.

### Function

The 172 Series manifold mixing station is designed for use in manifold-based hydronic distribution systems. The manifold mixing station incorporates a thermostatic actuator with built-in sensor which keeps the flow temperature at a constant set value for use in low temperature systems such as floor radiant panels. (7) A removable, primary circuit hydraulic separator with check valve is also supplied. The hydraulic separator is essential when there is a primary circuit circulation pump and when radiator circuits or fan coils are controlled by

thermostatic or thermo-electric valves. When connecting to a Caleffi HydroLink™ or hydraulic separator without a primary pump, the hydraulic separator can be removed and the manifold mixing station can be connected directly. The 172 station, like the TwistFlow™ Series 668S1 distribution manifolds, can be configured with 3 to 13 circuit outlets offering similar benefits with built-in sight flow meters/adjustable balancing valves and optional TwisTop™ thermo-electric zone actuators.

## LOW TEMPERATURE MANIFOLD MIXING STATIONS



### Thermostatic mixing station kit

For field assembly to a Caleffi radiant manifold assembly. Grundfos UPS 15–58 three-speed pump or Alpha 25-55U. 1" NPT male adapters included to connect to manifold. 3/4" NPT female riser connections. Includes built-in hydraulic separator.

Code	Description	Lbs	USD
NA17256HE	Thermostatic mixing, Alpha 25-55U	4.1	1,234.00
NA17256	Thermostatic mixing, UPS 15-58U	4.1	968.00
NA16002	Alpha 25-55U replacement pump	2.3	530.00
NA10038	UPS 15-58U replacement pump	2.3	261.00
F19153	Replacement mixing valve	1.6	295.00

BRASS DISTRIBUTION MANIFOLDS

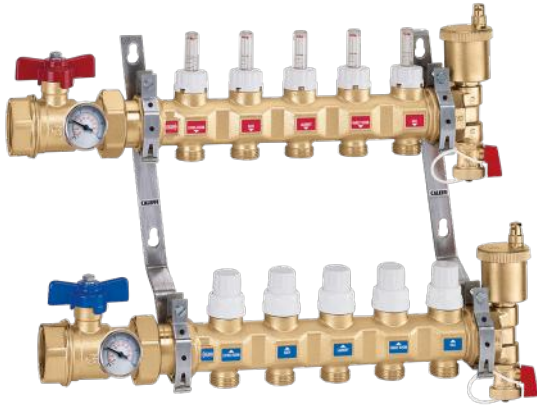

668S1  
TwistFlow™ assembly

Pre-assembled radiant manifold consisting of return distribution manifold complete with built-in shut-off valves suitable for thermo-electric actuator and supply distribution manifold complete with built-in sight flow meters and balancing valves with 2" gauges 30°–210°F scale.

1" or 1¼" NPT inlet ball valves.

Temperature gauges.

Max. working pressure: 150 psi.

Max. working temperature: 180°F.

Max. peak temperature: 200°F.

Loop Cv: 1.23 (combined supply & return ports).

Flow meter scale: ¼ – 2 gpm.

Outlet center distance: 2".

Models with "...IN" suffix are built inverted (tubing connections going upward).

Code	Description	No.	Outlets	Lbs	USD
6686C5S1A	1"	3	¾" M	17	588.00
6686C5S1A IN	1"	3	¾" M	17	588.00
6686D5S1A	1"	4	¾" M	18	673.00
6686D5S1A IN	1"	4	¾" M	18	673.00
6686E5S1A	1"	5	¾" M	19	757.00
6686E5S1A IN	1"	5	¾" M	19	757.00
6686F5S1A	1"	6	¾" M	21	844.00
6686F5S1A IN	1"	6	¾" M	21	844.00
6686G5S1A	1"	7	¾" M	23	928.00
6686G5S1A IN	1"	7	¾" M	23	928.00
6686H5S1A	1"	8	¾" M	24	1,016.00
6686H5S1A IN	1"	8	¾" M	24	1,016.00
6686I5S1A	1"	9	¾" M	26	1,099.00
6686I5S1A IN	1"	9	¾" M	26	1,099.00
6686L5S1A	1"	10	¾" M	28	1,185.00
6686L5S1A IN	1"	10	¾" M	28	1,185.00
6686M5S1A	1"	11	¾" M	29	1,270.00
6686M5S1A IN	1"	11	¾" M	29	1,270.00
6686N5S1A	1"	12	¾" M	31	1,355.00
6686N5S1A IN	1"	12	¾" M	31	1,355.00
6686O5S1A	1"	13	¾" M	33	1,441.00
6686O5S1A IN	1"	13	¾" M	33	1,441.00

Code	Description	No.	Outlets	Lbs	USD
6687C5S1A	1¼"	3	¾" M	17	622.00
6687C5S1A IN	1¼"	3	¾" M	17	622.00
6687D5S1A	1¼"	4	¾" M	18	709.00
6687D5S1A IN	1¼"	4	¾" M	18	709.00
6687E5S1A	1¼"	5	¾" M	19	794.00
6687E5S1A IN	1¼"	5	¾" M	19	794.00
6687F5S1A	1¼"	6	¾" M	21	879.00
6687F5S1A IN	1¼"	6	¾" M	21	879.00
6687G5S1A	1¼"	7	¾" M	23	963.00
6687G5S1A IN	1¼"	7	¾" M	23	963.00
6687H5S1A	1¼"	8	¾" M	24	1,050.00
6687H5S1A IN	1¼"	8	¾" M	24	1,050.00
6687I5S1A	1¼"	9	¾" M	26	1,136.00
6687I5S1A IN	1¼"	9	¾" M	26	1,136.00
6687L5S1A	1¼"	10	¾" M	28	1,220.00
6687L5S1A IN	1¼"	10	¾" M	28	1,220.00
6687M5S1A	1¼"	11	¾" M	29	1,304.00
6687M5S1A IN	1¼"	11	¾" M	29	1,304.00
6687N5S1A	1¼"	12	¾" M	31	1,389.00
6687N5S1A IN	1¼"	12	¾" M	31	1,389.00
6687O5S1A	1¼"	13	¾" M	33	1,475.00
6687O5S1A IN	1¼"	13	¾" M	33	1,475.00

Manifolds and accessories

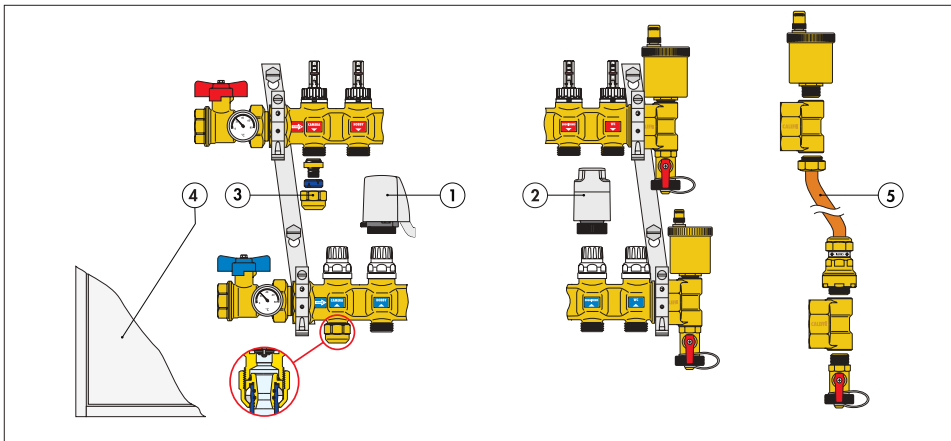

1. Thermo-electric actuator 6564 Series.
2. Thermo-electric actuator with manual open handle, 6563 Series.
3. Self-adjusting Universal PEX fitting, 680, 682 Series.
4. Inspection wall box, 659 Series.
5. Differential by-pass kit, code 668000.

**PUMP AND VALVE TEMPERATURE MIXING UNITS**



**166 HydroMixer™**

Thermostatic adjustable temperature mixing unit with insulation. Grundfos UPS 15-58 three speed pump. Grundfos Alpha 25-55U pump. Temperature gauges. Shut-off ball valves. Compatible with 5599 Hydrolink Series. Male union connections (select top and bottom fitting sets below). Max working pressure: 145 psi. Adjustable range: 80° – 125°F. Power supply: 115 V 50/60 Hz.

Code	Description	Lbs	USD
166600A	Dual line with 15-58 pump on right	22	<b>1,397.00</b>
166610A	Dual line with 15-58 pump on left	22	<b>1,397.00</b>
166602A	Dual line with Alpha pump on right	22	<b>1,651.00</b>
166612A	Dual line with Alpha pump on left	22	<b>1,651.00</b>



Wall bracket fits 166 and 167 Series.

Code	Description	Lbs	USD
165001	Wall bracket	0.1	<b>64.00</b>



Optional differential pressure bypass valve fits 166 and 167 Series.

Code	Description	Lbs	USD
519006	Differential pressure by-pass valve	1.0	<b>71.60</b>



**167 HydroMixer™**

Motorized temperature mixing unit with insulation. Three-point floating 24 VAC actuator for use with separately-sourced outdoor reset controller. Grundfos UPS 15-58 three speed pump. Grundfos Alpha 25-55U pump. Temperature gauges. Shut-off ball valves. Compatible with 5599 Hydrolink Series. Male union connections (select top and bottom fitting sets below). Max working pressure: 145 psi. Primary inlet temperature range: 40° – 212°F. Power supply: 115 V 50/60 Hz. Valve actuator: 24 V AC

Code	Description	Lbs	USD
167600A	Dual line with 15-58 pump on right	23	<b>1,651.00</b>
167610A	Dual line with 15-58 pump on left	23	<b>1,651.00</b>
167602A	Dual line with Alpha pump on right	23	<b>1,904.00</b>
167612A	Dual line with Alpha pump on left	23	<b>1,904.00</b>



Top outlet fitting set fits 166 and 167 Series. Includes (2) 1 1/4" union nuts, (2) tail pieces and (2) washers. Will not fit bottom inlet thread.

Code	Description	Lbs	USD
NA16069	1" sweat union outlet fittings	1.0	<b>65.60</b>



Bottom Inlet fitting set fits 166 and 167 Series. Includes (2) 1 1/2" union nuts, (2) tail pieces and (2) washers. Will not fit top outlet thread.

Code	Description	Lbs	USD
NA16169	1" sweat union inlet fittings	1.0	<b>66.40</b>



Top outlet fitting set fits 166 and 167 Series. Includes (2) 1 1/4" union nuts, (2) tail pieces and (2) washers. Will not fit bottom inlet thread.

Code	Description	Lbs	USD
NA16060	1" NPT female union outlet fittings	1.0	<b>74.50</b>



Bottom Inlet fitting set fits 166 and 167 Series. Includes (2) 1 1/2" union nuts, (2) tail pieces and (2) washers. Will not fit top outlet thread.

Code	Description	Lbs	USD
NA16160	1" NPT female union inlet fittings	1.0	<b>75.20</b>

**BOXES FOR DISTRIBUTION MANIFOLDS**



**659 Manifold cabinet**

Housing wall box fits 663 and 668S1 Series manifolds. Adjustable depth: 4 3/8" – 5 1/2". Powder coated painted 18 gauge sheet metal. With push-fit clamp.

Code	Description	H	Max Outlets	Lbs	USD
659044	16" width	20"	3	17	<b>340.00</b>
659064	24" width	20"	6	23	<b>372.00</b>
659084	32" width	20"	10	30	<b>438.00</b>
659104	40" width	20"	13	37	<b>502.00</b>
659124	48" width"	20"	17	44	<b>569.00</b>

Rough opening dimensions

**FITTINGS FOR DISTRIBUTION MANIFOLDS AND MIXING STATIONS**



(680504A shown)

**680  
Universal  
PEX fittings**

680 Series fittings are compatible with any ASTM F876 single layer PEX.  
Max. working pressure: 150 psi.  
Working temperature range for ASTM F876 PEX piping: 40° – 180°F.

Code	Description	Compression ring	Lbs	USD
<b>680507</b>	5/16" nominal PEX	Blue	0.2	<b>10.20</b>
<b>680503A</b>	3/8" nominal PEX	Black	0.2	<b>10.20</b>
<b>680504A</b>	1/2" nominal PEX	Blue	0.2	<b>10.20</b>
<b>680555A</b>	5/8" nominal PEX	Black	0.2	<b>10.20</b>
<b>680505A</b>	3/4" nominal PEX	Brass	0.2	<b>10.20</b>



(682530A shown)

**682  
Universal  
PEX-AL-PEX fittings**

682 Series fittings are compatible with any ASTM F1281 multilayer PEX-AL-PEX pipe.  
Max. working pressure: 150 psi.  
Working temperature range for ASTM F1281 PEX-AL-PEX piping: 40° – 200°F with tubing rated 200°F.

Code	Description	Lbs	USD
<b>682530A</b>	3/8" nominal PEX-AL-PEX	0.2	<b>10.40</b>
<b>682540A</b>	1/2" nominal PEX-AL-PEX	0.2	<b>10.40</b>
<b>682545A</b>	5/8" nominal PEX-AL-PEX	0.2	<b>11.00</b>
<b>682550A</b>	3/4" nominal PEX-AL-PEX	0.2	<b>19.70</b>



**NA102**

Sweat connection fitting fits 1/2" copper.  
Max. working pressure: 150 psi.  
Working temperature range: 41° – 250°F.  
Chrome plated nut.  
Does not work with 668S1 and 172 Series.

Code	Description	Lbs	USD
<b>NA10262</b>	1/2" sweat	0.2	<b>11.30</b>



**NA103**

NPT connection fitting.  
Max. working pressure: 150 psi.  
Working temperature range: 41° – 250°F.  
Chrome plated nut.  
Does not work with 668S1 and 172 Series.

Code	Description	Lbs	USD
<b>NA10313</b>	1/2" NPT male	0.2	<b>12.20</b>



Double nipple for coupling PEX fittings.

Code	Description	Lbs	USD
<b>942550</b>	3/4" x 3/4" thread	0.1	<b>12.60</b>



**386**

Cap to plug unused manifold outlets on 592, 663 and 668S1 Series.

Code	Description	Lbs	USD
<b>386500</b>	3/4" straight thread	0.2	<b>10.20</b>

**THERMO ELECTRIC ACTUATORS FOR MANIFOLDS AND VALVES**



**6563  
TwisTop™**

TwisTop™ thermo-electric actuator.  
Twist the top to manually open.  
Power supply: 24 V AC/DC.  
Initial current draw: ≤ 250 mA.  
Power consumption: 3 W.  
Rating of micro-switch contacts: 5 A (24 V).  
31 1/2" wire lead connection.  
US Patent 7,617,989 B2.

Code	Description	Lbs	USD
<b>656344</b>	24 V AC/DC	0.4	<b>111.00</b>
<b>656354</b>	24 V AC/DC with micro-switch	0.4	<b>131.00</b>
<b>656354R</b>	24 V AC/DC with micro-switch REHAU	0.4	<b>144.00</b>



**6564**

Low current draw thermo-electric actuator.  
Hermetically sealed for upside down installation.  
Pop-up feature.  
Power supply: 24 V AC/DC.  
Initial current draw: ≤ 250 mA.  
Power consumption: 3 W.  
Rating of micro-switch contacts: 5 A (24 V).  
31 1/2" wire lead connection.

Code	Description	Lbs	USD
<b>656404</b>	24 V AC/DC	0.4	<b>82.80</b>
<b>656414</b>	24 V AC/DC with micro-switch	0.4	<b>105.00</b>

**ACCESSORIES**



Replacement balance/flow meter fits 668S1 Series manifold.  
Flow meter scale: ¼ — 2 gpm.

Code	Description	Lbs	USD
<b>F69600</b>	Fits 668S1 supply manifold	0.2	<b>29.40</b>



Replacement shut-off valve fits 668S1 Series manifold.

Code	Description	Lbs	USD
<b>F69590</b>	Fits 668S1 return manifold	0.3	<b>23.40</b>



Wrench for tightening PEX fitting to manifolds.

Code	Description	Lbs	USD
<b>387100</b>	26 mm x 30 mm	1.5	<b>47.80</b>



Replacement shut-off valve fits old 668 & 663 Series manifold.

Code	Description	Lbs	USD
<b>69122 CST</b>	Fits 668 & 663 return manifold	0.3	<b>13.00</b>



Replacement balancing valve for old 663 Series manifold.

Code	Description	Lbs	USD
<b>R69176</b>	Fits 663 supply manifold	0.3	<b>20.00</b>



**NA669**

Flow meter fits old 668 & 663 manifolds.  
Max: temperature: 180°F (669050).  
Max: temperature: 210°F (NA669 Series).  
¼" straight male x ¼" straight female connections.

Code	Description	Lbs	USD
<b>NA669150</b>	¼ — 1 GPM High Temp.	0.3	<b>34.50</b>
<b>NA669250</b>	½ — 2 GPM High Temp.	0.3	<b>34.50</b>



**5020**

Replacement air vent fits radiant manifolds.  
Brass body.  
Hygroscopic safety air vent cap.  
Max. working pressure: 150 psi.  
Max discharge pressure: 32 psi.  
Max. working temperature: 250°F.

Code	Description	Lbs	USD
<b>502043 CST</b>	½" straight thread	0.6	<b>24.50</b>



Plastic replacement/test cap fits 5020 Series, for pressure testing manifolds.

Code	Description	Lbs	USD
<b>R56214</b>	Vent cap	0.1	<b>2.20</b>

**675**

Snap-on thermometer directly to PEX, PEX-AL-PEX and copper piping.  
Box of 10 comes with 1 syringe of thermo conductive paste.

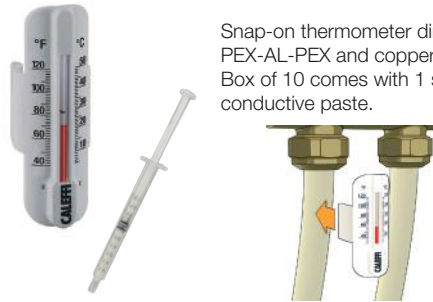

Code	Description	Lbs	USD
<b>675900A</b>	¾" & 5/8" PEX & ½" copper	0.2	<b>10.80</b>
<b>R69413</b>	Syringe of thermo conductive paste	0.1	<b>7.60</b>

**688**

Temperature gauge with well pocket fitting for inserting into manifold ball valves.  
Working Temperature range: 30° — 210°F.  
Face dial diameter: 2".



Code	Description	Lbs	USD
<b>R39591</b>	Replacement gauge	0.1	<b>26.50</b>
<b>688003A</b>	Gauge with pocket well	0.2	<b>40.50</b>
<b>NA10498</b>	Replacement pocket well, low lead	0.1	<b>4.00</b>
<b>F67037</b>	O-ring fits NA10498	0.1	<b>0.80</b>

# CUTTING-EDGE INNOVATION IN TEMPERATURE MIXING



**Caleffi mixing valves lead the way.** From  $\frac{3}{8}$ " under-sink scald protection valves to 3" flanged digital master mixing valves, a full selection is available for residential and commercial plumbing and hydronic applications. **Over 60 years of innovation and global experience** assure high quality and proven reliability. A wide selection of double union connection types work with copper, iron, stainless steel and non-metallic pipes. **Approvals include compliance with U.S. and Canadian plumbing codes. CALEFFI GUARANTEED.**



# MIXING VALVES FOR PLUMBING AND HYDRONICS

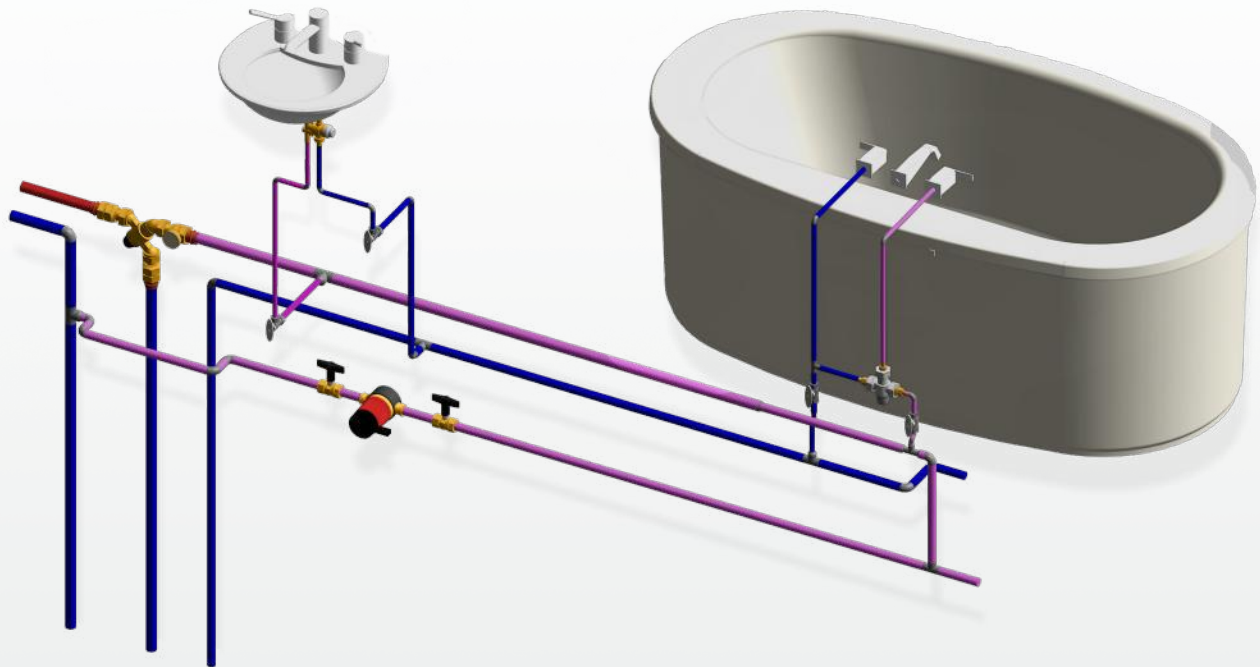

6A

This diagram is for illustration purposes only



 **BIM**  
bim.caleffi.com

## PRODUCTS INCLUDED IN SECTION

- Thermostatic mixing valves for plumbing and hydronics
- High flow thermostatic mixing valves for plumbing and hydronics
- Scald protection thermostatic mixing valves for plumbing
- Electronic mixing valves for plumbing
- Thermostatic mixing valve kits for domestic water heaters

**THERMOSTATIC MIXING VALVES FOR PLUMBING AND HYDRONICS**



**521 MixCal™ sweat**

Adjustable thermostatic mixing valve for point of distribution in domestic water systems and radiant hydronic heating systems. Low-lead brass body. Locking set point knob. Max. working pressure: 200 psi. Max. inlet temperature: 200°F. Adjustable range: 85° – 150°F. Min. flow for optimum performance: 1.0 gpm. (0 gpm with recirculation) Flow at 20 psid: 14 gpm.

Code	Description	Cv	Lbs	USD
<b>521409A</b>	1/2" sweat union	3.0	2.4	<b>200.00</b>
<b>521409AC</b>	1/2" sweat union, check valves	3.0	2.4	<b>221.00</b>
<b>521509A</b>	3/4" sweat union	3.0	2.4	<b>209.00</b>
<b>521509AC</b>	3/4" sweat union, check valves	3.0	2.4	<b>240.00</b>
<b>521609A</b>	1" sweat union	3.0	2.4	<b>249.00</b>
<b>521609AC</b>	1" sweat union, check valves	3.0	2.4	<b>278.00</b>



**521 MixCal™ NPT**

Adjustable thermostatic mixing valve for point of distribution in domestic water systems and radiant hydronic heating systems. Low-lead brass body. Locking set point knob. Max. working pressure: 200 psi. Max. inlet temperature: 200°F. Adjustable range: 85° – 150°F. Min. flow for optimum performance: 1.0 gpm. (0 gpm with recirculation) Flow at 20 psid: 14 gpm.

Code	Description	Cv	Lbs	USD
<b>521400A</b>	1/2" NPT male union	3.0	2.4	<b>209.00</b>
<b>521400AC</b>	1/2" NPT male union, check valves	3.0	2.4	<b>230.00</b>
<b>521500A</b>	3/4" NPT male union	3.0	2.4	<b>218.00</b>
<b>521500AC</b>	3/4" NPT male union, check valves	3.0	2.4	<b>249.00</b>
<b>521600A</b>	1" NPT male union	3.0	2.4	<b>259.00</b>
<b>521600AC</b>	1" NPT male union, check valves	3.0	2.4	<b>288.00</b>



**521 MixCal™ press**

Adjustable thermostatic mixing valve for point of distribution in domestic water systems and radiant hydronic heating systems. Low-lead brass body. Locking set point knob. Max. working pressure: 200 psi. Max. inlet temperature: 200°F. Adjustable range: 85° – 150°F. Min. flow for optimum performance: 1.0 gpm. (0 gpm with recirculation) Flow at 20 psid: 14 gpm.

Code	Description	Cv	Lbs	USD
<b>521406A</b>	1/2" Press union	3.0	2.4	<b>213.00</b>
<b>521406AC</b>	1/2" Press union, check valves	3.0	2.5	<b>234.00</b>
<b>521506A</b>	3/4" Press union	3.0	2.4	<b>218.00</b>
<b>521506AC</b>	3/4" Press union, check valves	3.0	2.5	<b>271.00</b>
<b>521606A</b>	1" Press union	3.0	2.6	<b>264.00</b>
<b>521606AC</b>	1" Press union, check valves	3.0	3.1	<b>287.00</b>



**521 MixCal™ PEX**

Adjustable thermostatic mixing valve for point of distribution in domestic water systems and radiant hydronic heating systems. Low-lead brass body. Locking set point knob. Max. working pressure: 200 psi. Max. inlet temperature: 200°F. Adjustable range: 85° – 150°F. Min. flow for optimum performance: 1.0 gpm. (0 gpm with recirculation) Flow at 20 psid: 14 gpm. PEX crimp: ASTM F1807 PEX expansion: ASTM F1960

Code	Description	Cv	Lbs	USD
<b>521407A</b>	1/2" PEX crimp union	3.0	2.4	<b>200.00</b>
<b>521407AC</b>	1/2" PEX crimp union, check valves	3.0	2.9	<b>221.00</b>
<b>521408A</b>	1/2" PEX expansion union	3.0	2.4	<b>200.00</b>
<b>521408AC</b>	1/2" PEX expansion union, check valves	3.0	2.9	<b>221.00</b>
<b>521507A</b>	3/4" PEX crimp union	3.0	2.4	<b>209.00</b>
<b>521507AC</b>	3/4" PEX crimp union, check valves	3.0	2.9	<b>240.00</b>
<b>521508A</b>	3/4" PEX expansion union	3.0	2.4	<b>209.00</b>
<b>521508AC</b>	3/4" PEX expansion union, check valves	3.0	2.9	<b>240.00</b>
<b>521607A</b>	1" PEX crimp union	3.0	2.4	<b>249.00</b>
<b>521607AC</b>	1" PEX crimp union, check valves	3.0	2.9	<b>278.00</b>
<b>521608A</b>	1" PEX expansion union	3.0	2.4	<b>249.00</b>
<b>521608AC</b>	1" PEX expansion union, check valves	3.0	2.9	<b>278.00</b>

Meets requirements of NSF/ANSI/CAN 372. Complies with ASSE 1017, CSA B125.3, UPC, IPC, Low Lead Laws and listed by ICC-ES for use in accordance with the U.S. and Canadian plumbing codes.



**THERMOSTATIC MIXING VALVES FOR PLUMBING AND HYDRONICS**



**521 MixCal™ sweat**

Adjustable thermostatic mixing valve for point of distribution in domestic water systems and radiant hydronic heating systems. Low-lead brass body, with gauge. Locking set point knob. Max. working pressure: 200 psi. Max. inlet temperature: 200°F. Adjustable range: 85° – 150°F. Min. flow for optimum performance: 1.0 gpm. (0 gpm with recirculation) Flow at 20 psid: 14 gpm. Optional Gauge scale: 30° – 210°F.

Code	Description	Cv	Lbs	USD
521419A	1/2" sweat union	3.0	2.9	<b>238.00</b>
521419AC	1/2" sweat union, check valves	3.0	2.9	<b>258.00</b>
521519A	3/4" sweat union	3.0	2.9	<b>246.00</b>
521519AC	3/4" sweat union, check valves	3.0	2.9	<b>276.00</b>
521619A	1" sweat union	3.0	2.9	<b>287.00</b>
521619AC	1" sweat union, check valves	3.0	2.9	<b>317.00</b>



**521 MixCal™ NPT**

Adjustable thermostatic mixing valve for point of distribution in domestic water systems and radiant hydronic heating systems. Low-lead brass body with gauge. Locking set point knob. Max. working pressure: 200 psi. Max. inlet temperature: 200°F. Adjustable range: 85° – 150°F. Min. flow for optimum performance: 1.0 gpm. (0 gpm with recirculation) Flow at 20 psid: 14 gpm. Optional Gauge scale: 30° – 210°F.

Code	Description	Cv	Lbs	USD
521410A	1/2" NPT male union	3.0	2.9	<b>246.00</b>
521410AC	1/2" NPT male union, check valves	3.0	2.9	<b>266.00</b>
521510A	3/4" NPT male union	3.0	2.9	<b>256.00</b>
521510AC	3/4" NPT male union, check valves	3.0	2.9	<b>284.00</b>
521610A	1" NPT male union	3.0	2.9	<b>298.00</b>
521610AC	1" NPT male union, check valves	3.0	2.9	<b>325.00</b>



**521 MixCal™ press**

Adjustable thermostatic mixing valve for point of distribution in domestic water systems and radiant hydronic heating systems. Low-lead brass body with gauge. Locking set point knob. Max. working pressure: 200 psi. Max. inlet temperature: 200°F. Adjustable range: 85° – 150°F. Min. flow for optimum performance: 1.0 gpm. (0 gpm with recirculation) Flow at 20 psid: 14 gpm. Optional Gauge scale: 30° – 210°F.

Code	Description	Cv	Lbs	USD
521416A	1/2" Press union	3.0	2.9	<b>250.00</b>
521416AC	1/2" Press union, check valves	3.0	3.0	<b>269.00</b>
521516A	3/4" Press union	3.0	2.9	<b>256.00</b>
521516AC	3/4" Press union, check valves	3.0	3.0	<b>307.00</b>
521616A	1" Press union	3.0	3.1	<b>302.00</b>
521616AC	1" Press union, check valves	3.0	3.5	<b>324.00</b>



**521 MixCal™ PEX**

Adjustable thermostatic mixing valve for point of distribution in domestic water systems and radiant hydronic heating systems. Low-lead brass body with gauge. Locking set point knob. Max. working pressure: 200 psi. Max. inlet temperature: 200°F. Adjustable range: 85° – 150°F. Min. flow for optimum performance: 1.0 gpm. (0 gpm with recirculation) Flow at 20 psid: 14 gpm. Optional Gauge scale: 30° – 210°F. PEX crimp: ASTM F1807. PEX expansion: ASTM F1960.

Code	Description	Cv	Lbs	USD
521417A	1/2" PEX crimp union	3.0	2.5	<b>238.00</b>
521417AC	1/2" PEX crimp union, checks	3.0	2.9	<b>258.00</b>
521418A	1/2" PEX expansion union	3.0	2.5	<b>238.00</b>
521418AC	1/2" PEX expansion union, checks	3.0	2.9	<b>258.00</b>
521517A	3/4" PEX crimp union	3.0	2.5	<b>246.00</b>
521517AC	3/4" PEX crimp union, checks	3.0	2.9	<b>276.00</b>
521518A	3/4" PEX expansion union	3.0	2.5	<b>246.00</b>
521518AC	3/4" PEX expansion union, checks	3.0	2.9	<b>276.00</b>
521617A	1" PEX crimp union	3.0	2.5	<b>287.00</b>
521617AC	1" PEX crimp union, checks	3.0	2.9	<b>317.00</b>
521618A	1" PEX expansion union	3.0	2.5	<b>287.00</b>
521618AC	1" PEX expansion union, checks	3.0	2.9	<b>317.00</b>

Meets requirements of NSF/ANSI/CAN 372. Complies with ASSE 1017, CSA B125.3, UPC, IPC, Low Lead Laws and listed by ICC-ES for use in accordance with the U.S. and Canadian plumbing codes.

6A

**THERMOSTATIC MIXING VALVES FOR PLUMBING AND HYDRONICS**



Point of distribution mixed temperature gauge adaptor fits 1" male union thread mixing valves.  
Removable gauge fits into pocket well.  
Dual scale: 30°—210°F (0°—100°C).  
Gauge accuracy: ± 6°F.  
Gauge dial: 2" diameter.  
Certified: Low-lead brass.

Code	Description	Lbs	USD
<b>NA10328</b>	½" sweat with gauge	0.4	<b>59.30</b>
<b>NA10056</b>	¾" sweat with gauge	0.4	<b>65.20</b>
<b>NA10058</b>	1" sweat with gauge	0.4	<b>71.60</b>
<b>NA10358</b>	1" union thread with gauge	0.4	<b>37.30</b>
<b>688003A</b>	Replacement gauge with pocket well	0.5	<b>40.50</b>
<b>R39591</b>	Replacement gauge	0.1	<b>26.50</b>
<b>NA10498</b>	Pocket well, plated	0.1	<b>4.00</b>



**521 MixCal™ Body**

Replacement body (½", ¾", 1" valve).  
See fitting selection table in Section 8.

Code	Description	Cv	Lbs	USD
<b>521101A</b>	1" union body	3.0	1.9	<b>153.00</b>

**Construction details**

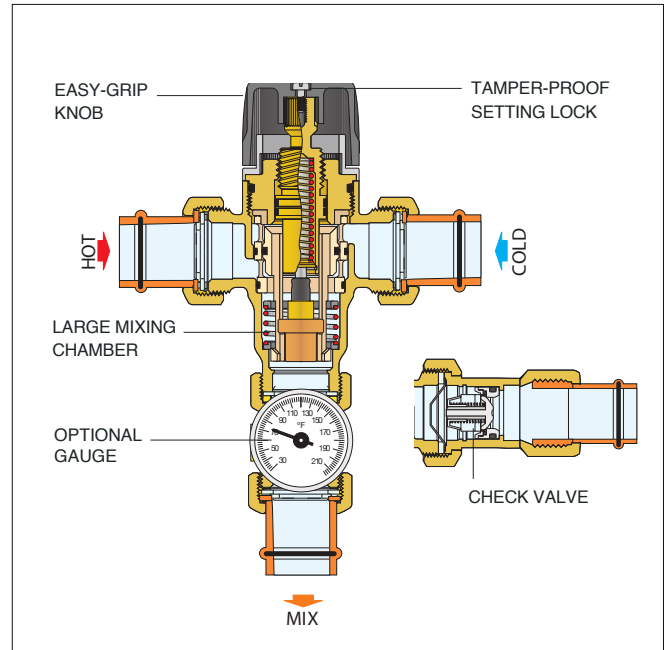

**ACCESSORIES**



Replacement check valves for 521 (AC models).

Code	Description	Lbs	USD
<b>NA10405</b>	Replacement for 521 PEX, press fittings	0.1	<b>2.50</b>
<b>R39204</b>	Replacement for 521 sweat, NPT fittings	0.1	<b>3.50</b>



Conical inlet filter for 521 mixing valves.

Code	Description	Lbs	USD
<b>F52429</b>	Conical filter for 521 mixing valve	0.1	<b>5.00</b>

**HIGH FLOW THERMOSTATIC MIXING VALVES FOR PLUMBING AND HYDRONICS**



**5231 MixCal+™ Body**

Replacement body includes nuts and washers.  
See fitting selection table in Section 8.

Code	Description	Min - Max Flow (gpm)	Cv	Lbs	USD
<b>523179A</b>	For 1" and 1¼" sizes	4.4 to 40	7.6	5.0	<b>1,129.00</b>
<b>523199A</b>	For 1½" and 2" sizes	8.8 to 70	14.2	14.2	<b>1,616.00</b>



**5231 MixCal+™ Sweat**

Adjustable thermostatic mixing valve for domestic water systems and radiant hydronic systems.  
DZR low lead brass body.  
Max. working pressure: 200 psi.  
Max. inlet temperature: 195°F.  
Adjustable range: 95°—150°F.  
Gauge scale: 30°—210°F.  
Gauge accuracy: ± 6°F.  
Gauge dial: 2" diameter.  
Min. flow for optimum performance: 4.4 gpm. (0 gpm with recirculation)  
Flow at 20 psid: 40 GPM

Code	Description	Cv	Lbs	USD
<b>523177A</b>	1¼" sweat union	7.6	9.0	<b>1,412.00</b>

Meets requirements of NSF/ANSI/CAN 372. Complies with ASSE 1017, CSA B125.3, UPC, IPC, Low Lead Laws and listed by ICC-ES for use in accordance with the U.S. and Canadian plumbing codes.

**HIGH FLOW THERMOSTATIC MIXING VALVES FOR PLUMBING AND HYDRONICS**



**5231  
MixCal+™ sweat**

Adjustable thermostatic mixing valve for domestic water systems and radiant hydronic systems.  
DZR low lead brass body.  
Max. working pressure: 200 psi.  
Max. inlet temperature: 195°F.  
Adjustable range: 95° – 150°F.

Code	Description	Min - Max Flow (gpm)	Cv	Lbs	USD
523168A	1" sweat union	4.4 to 40	7.0	7.0	<b>1,257.00</b>
523178A	1¼" sweat union	4.4 to 40	7.6	7.0	<b>1,313.00</b>
523188A	1½" sweat union	8.8 to 70	13	17	<b>1,973.00</b>
523198A	2" sweat union	8.8 to 70	14	18	<b>2,074.00</b>



Point of distribution mixed temperature gauge adaptor fits MixCal+™ High Flow 5231 Series mixing valves.  
Removable gauge fits into pocket well.  
Dual scale: 30° – 210°F (0° – 100°C).  
Gauge accuracy: ± 6°F.  
Gauge dial: 2" diameter.  
Certified: Low-lead brass.

Code	Description	Lbs	USD
NA10315	1¼" sweat	0.5	<b>144.00</b>
NA10476	1" and 1¼" male x female union	3.0	<b>165.00</b>
NA10461	1½" and 2" male x female union	4.0	<b>283.00</b>
688003A	Replacement gauge with pocket well	0.2	<b>40.50</b>
R39591	Replacement gauge	0.1	<b>26.50</b>



**5231  
MixCal+™ NPT**

Adjustable thermostatic mixing valve for domestic water systems and radiant hydronic systems.  
DZR low lead brass body.  
Max. working pressure: 200 psi.  
Max. inlet temperature: 195°F.  
Adjustable range: 95° – 150°F.

Code	Description	Min - Max Flow (gpm)	Cv	Lbs	USD
523160A	1" NPT male union	4.4 to 40	7.0	7.0	<b>1,270.00</b>
523170A	1¼" NPT male union	4.4 to 40	7.6	7.0	<b>1,372.00</b>
523180A	1½" NPT male union	8.8 to 70	13	17	<b>2,023.00</b>
523190A	2" NPT male union	8.8 to 70	14	18	<b>2,127.00</b>



Inlet check valve assembly for installing on inlet union tail pieces of 5231 mixing valves.  
Stainless steel body. No Lead. Ordered separately, field installed. Assembly examples shown below.



523177A shown with (2) NA10366      523178A shown with (2) NA10366

Code	Description	Lbs	USD
NA10366	Check valve assembly 1" and 1¼"	1.0	<b>103.00</b>
NA10367	Check valve assembly 1½" & 2"	1.5	<b>228.00</b>



**5231  
MixCal+™ press**

Adjustable thermostatic mixing valve for domestic water systems and radiant hydronic systems.  
DZR low lead brass body.  
Max. working pressure: 200 psi.  
Max. inlet temperature: 195°F.  
Adjustable range: 95° – 150°F.

Code	Description	Min - Max Flow (gpm)	Cv	Lbs	USD
523166A	1" press union	4.4 to 40	7.0	7.0	<b>1,337.00</b>
523176A	1¼" press union	4.4 to 40	7.6	7.0	<b>1,399.00</b>
523186A	1½" press union	8.8 to 70	13	11	<b>2,150.00</b>
523196A	2" press union	8.8 to 70	14.2	12	<b>2,391.00</b>

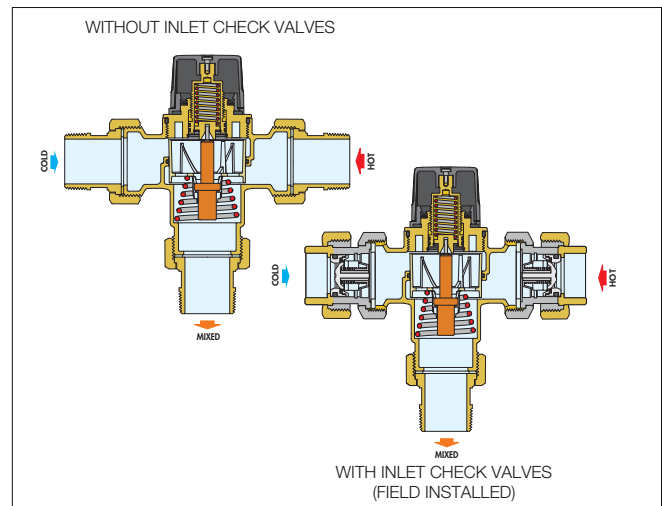

Meets requirements of NSF/ANSI/CAN 372. Complies with ASSE 1017, CSA B125.3, UPC, IPC, Low Lead Laws and listed by ICC-ES for use in accordance with the U.S. and Canadian plumbing codes.

6A

**THERMOSTATIC MIXING VALVES FOR PLUMBING AND HYDRONICS**



**520 AngleMix™ sweat**

Body is DZR low lead brass with gauge.  
 Adjustment temperature range: 95° – 150°F.  
 Max. body pressure rating (static): 150 psi.  
 Max. working pressure (dynamic): 75 psi.  
 Max. inlet temperature: 195°F.  
 Gauge scale: 30° – 210°F.  
 Min. flow for optimum performance: ½" and ¾" valves 0.5 GPM, 1" valves 1 GPM.  
 (0 gpm with recirculation)  
 Flow at 20 psid: ½" and ¾" valves 9 GPM, 1" valves 16 GPM.

Code	Description	Cv	Lbs	USD
<b>520419A</b>	½" sweat union	2.0	1.7	<b>238.00</b>
<b>520419AC</b>	½" sweat union, checks	2.0	1.8	<b>258.00</b>
<b>520519A</b>	¾" sweat union	2.0	2.0	<b>256.00</b>
<b>520519AC</b>	¾" sweat union, checks	2.0	2.1	<b>284.00</b>
<b>520619A</b>	1" sweat union	3.5	3.7	<b>344.00</b>
<b>520619AC</b>	1" sweat union, check	3.5	3.8	<b>372.00</b>



**520 AngleMix™ press**

Body is DZR low lead brass with gauge.  
 Adjustment temperature range: 95° – 150°F.  
 Max. body pressure rating (static): 150 psi.  
 Max. working pressure (dynamic): 75 psi.  
 Max. inlet temperature: 195°F.  
 Gauge scale: 30° – 210°F.  
 Min. flow for optimum performance: ½" and ¾" valves 0.5 GPM, 1" valves 1 GPM.  
 (0 gpm with recirculation)  
 Flow at 20 psid: ½" and ¾" valves 9 GPM, 1" valves 16 GPM.

Code	Description	Cv	Lbs	USD
<b>520416A</b>	½" press union	2.0	1.8	<b>250.00</b>
<b>520416AC</b>	½" press union, check	2.0	1.8	<b>268.00</b>
<b>520516A</b>	¾" press union	2.0	2.0	<b>246.00</b>
<b>520516AC</b>	¾" press union, check	2.0	2.1	<b>307.00</b>
<b>520616A</b>	1" press union	3.5	3.7	<b>358.00</b>
<b>520616AC</b>	1" press union, check	3.5	3.9	<b>388.00</b>



**520 AngleMix™ NPT**

Body is DZR low lead brass with gauge.  
 Adjustment temperature range: 95° – 150°F.  
 Max. body pressure rating (static): 150 psi.  
 Max. working pressure (dynamic): 75 psi.  
 Max. inlet temperature: 195°F.  
 Gauge scale: 30° – 210°F.  
 Min. flow for optimum performance: ½" and ¾" valves 0.5 GPM, 1" valves 1 GPM.  
 (0 gpm with recirculation)  
 Flow at 20 psid: ½" and ¾" valves 9 GPM, 1" valves 16 GPM.

Code	Description	Cv	Lbs	USD
<b>520410A</b>	½" NPT male union	2.0	1.7	<b>246.00</b>
<b>520410AC</b>	½" NPT male union, checks	2.0	1.8	<b>266.00</b>
<b>520510A</b>	¾" NPT male union	2.0	2.0	<b>256.00</b>
<b>520510AC</b>	¾" NPT male union, checks	2.0	2.1	<b>284.00</b>
<b>520610A</b>	1" NPT male union	3.5	3.9	<b>353.00</b>
<b>520610AC</b>	1" NPT male union, check	3.5	4.0	<b>382.00</b>



**520 AngleMix™ Body**

Replacement body.  
 See fitting selection table in Section 8.

Code	Description	Cv	Lbs	USD
<b>520051A</b>	1" union body (½", ¾" valves)	2.0	2.0	<b>153.00</b>
<b>520061A</b>	1¼" union body (1" valves)	3.5	4.0	<b>214.00</b>

**Construction details**

**Anti-scale materials** The material used in the construction of the Caleffi AngleMix 520 Series thermostatic mixing valve reduces jamming caused by lime deposits. All the working parts such as shutter, seats and slide guides are made of a special anti-scale polymer material, with a low friction coefficient, assuring long term performance.

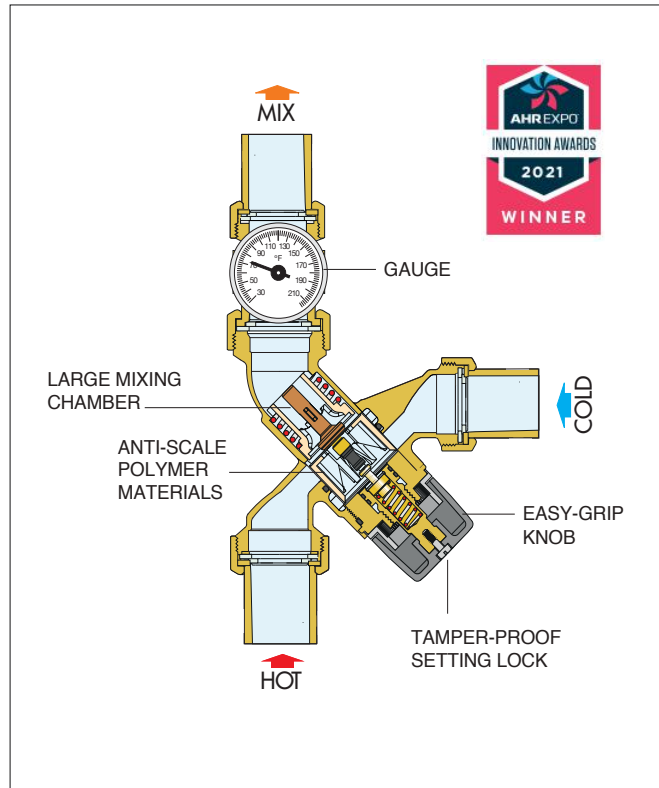

Meets requirements of NSF/ANSI/CAN 372. Complies with ASSE 1017, CSA B125.3, UPC, IPC, Low Lead Laws and listed by ICC-ES for use in accordance with the U.S. and Canadian plumbing codes.

**SCALD PROTECTION THERMOSTATIC MIXING VALVES FOR PLUMBING**



**5212 SinkMixer™**  
4-way Scald Protection Point of use

Thermostatic mixing valve for under sink and under counter applications where the user must be protected from the danger of scalding caused by excessively hot water. Temperature adjustment range: 95° – 120°F. Cold inlet temperature: Min. 39°F; Max. 85°F. Hot inlet temperature: Min. 120°F; Max. 195°F. Min flow for optimum performance 0.35 gpm. Flow at 20 psid: 2.3 gpm. Complies with NSF/ANSI/CAN 61. Cv = 0.52

Code	Description	Lbs	USD
<b>521201A</b>	3/8" compression	1.0	<b>113.00</b>
<b>521201AP</b>	3/8" compression, plug/fittings	1.1	<b>115.00</b>



**5213 TubMixer™**  
High-Flow Scald Protection

Adjustable thermostatic high-flow point of use mixing valve for Roman Tubs and other high-flow fixtures. Locking set point knob. Complete with check valves on both hot and cold inlets. Low-lead brass body. Max. working pressure: 150 psi. Max. inlet temperature: 185°F. Adjustable range: 85° – 120°F. Temperature control: ±3°F. Min. flow for optimum performance: 0.5 gpm. Flow at 20 psid: 9 gpm. Cv = 2

Code	Description	Lbs	USD
<b>521333A</b>	3/8" compression union	2.0	<b>136.00</b>
<b>521347A</b>	1/2" PEX crimp union	2.0	<b>136.00</b>
<b>521348A</b>	1/2" PEX expansion union	2.0	<b>136.00</b>
<b>521342A</b>	1/2" NPT male union	2.0	<b>136.00</b>
<b>521349A</b>	1/2" sweat union	2.0	<b>136.00</b>
<b>521357A</b>	3/4" PEX crimp union	2.0	<b>143.00</b>
<b>521358A</b>	3/4" PEX expansion union	2.0	<b>143.00</b>
<b>521352A</b>	3/4" NPT male union	2.0	<b>143.00</b>
<b>521359A</b>	3/4" sweat union	2.0	<b>143.00</b>
<b>521367A</b>	1" PEX crimp union	2.0	<b>221.00</b>
<b>521368A</b>	1" PEX expansion union	2.0	<b>221.00</b>
<b>521362A</b>	1" NPT male union	2.0	<b>230.00</b>
<b>521369A</b>	1" sweat union	2.0	<b>221.00</b>
<b>521301A*</b>	Replacement body, no fittings	1.5	<b>123.00</b>

\*See fitting selection table in Section 8.

Meets requirements of NSF/ANSI/CAN 372. Complies with ASSE 1070, CSA B125.3, UPC, IPC, Low Lead Laws and listed by ICC-ES for use in accordance with the U.S. and Canadian plumbing codes.

**Construction details SinkMixer™**

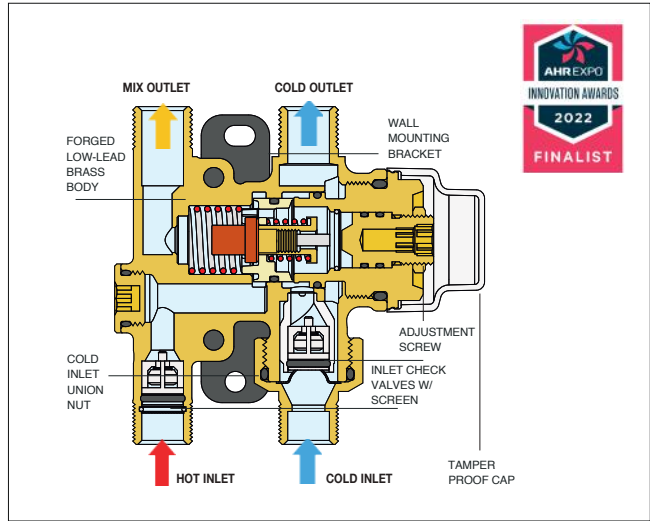

**SinkMixer™ Replacement check valve/filter kit.**

Code	Description	Lbs	USD
<b>F0001270</b>	Replacement check valve/filter kit	0.1	<b>6.80</b>



**SinkMixer™ 5-pack plug/nut fitting kit.**  
The cold outlet port plug is for single-pipe, mixed-water fixtures.

Code	Description	Lbs	USD
<b>NA10741</b>	5-pack plug/nut fitting kit	0.2	<b>17.10</b>

**Application diagram TubMixer™**

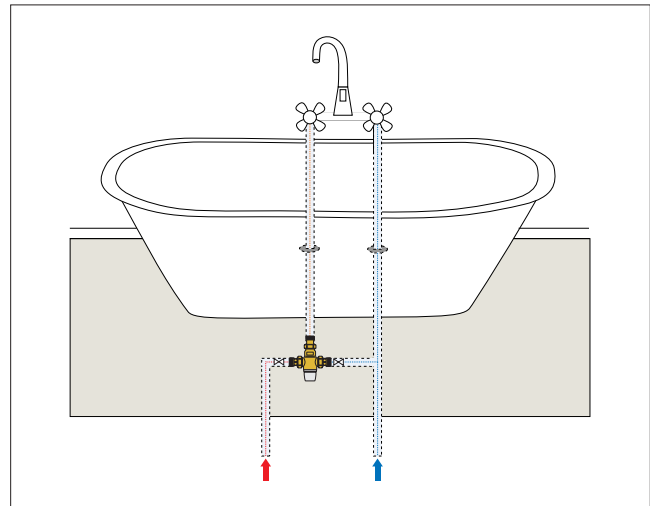

**ELECTRONIC MIXING VALVES FOR PLUMBING**



**6000 LEGIOMIX® sweat**

Electronic mixing valve with optional selectable programs for thermal disinfection of hot water recirculation system to kill Legionella bacteria.  
 Power: 24 VAC +/- 10% - 50/60 Hz - 6 VA. 115/24 VAC transformer included.  
 Adjustment temperature range: 70°—185°F.  
 Disinfection temperature range: 100°—185°F.  
 Max body pressure rating (static): 230 psi.  
 Max operating pressure: 150 psi.  
 Max. inlet temperature: 212°F.

Code	Description	Cv	Lbs	USD
600059A	¾" sweat union	9.7	5.1	<b>2,820.00</b>
600069A 001	1" sweat union, ¾" body	9.7	5.3	<b>2,972.00</b>
600069A	1" sweat union	21	7.3	<b>3,121.00</b>
600079A	1¼" sweat union	24	8.2	<b>3,174.00</b>
600089A	1½" sweat union	34	21	<b>3,603.00</b>
600099A	2" sweat union	48	22	<b>3,696.00</b>



**6000 LEGIOMIX® NPT**

Electronic mixing valve with optional selectable programs for thermal disinfection of hot water recirculation system to kill Legionella bacteria.  
 Power: 24 VAC +/- 10% - 50/60 Hz - 6 VA. 115/24 VAC transformer included.  
 Adjustment temperature range: 70°—185°F.  
 Disinfection temperature range: 100°—185°F.  
 Max body pressure rating (static): 230 psi.  
 Max operating pressure: 150 psi.  
 Max. inlet temperature: 212°F.

Code	Description	Cv	Lbs	USD
600054A	¾" NPT male union	9.7	5.1	<b>2,850.00</b>
600064A 001	1" NPT male union, ¾" body	9.7	5.3	<b>2,992.00</b>
600064A	1" NPT male union	21	7.3	<b>3,132.00</b>
600074A	1-¼" NPT male union	24	8.2	<b>3,230.00</b>
600084A	1½" NPT male union	34	21	<b>3,647.00</b>
600094A	2" NPT male union	48	22	<b>3,746.00</b>

Meets requirements of NSF/ANSI/CAN 372 and complies with ASSE 1017, CSA B125.3, UPC, IPC, Low Lead Laws and listed by ICC-ES for use in accordance with the U.S. and Canadian plumbing codes. Meets requirements of CSA Z317.1 Special Requirements For Plumbing Installations In Health Care Facilities.



**6000 LEGIOMIX® press**

Electronic mixing valve with optional selectable programs for thermal disinfection of hot water recirculation system to kill Legionella bacteria.  
 Power: 24 VAC +/- 10% - 50/60 Hz - 6 VA. 115/24 VAC transformer included.  
 Adjustment temperature range: 70°—185°F.  
 Disinfection temperature range: 100°—185°F.  
 Max body pressure rating (static): 230 psi.  
 Max operating pressure: 150 psi.  
 Max. inlet temperature: 212°F.

Code	Description	Cv	Lbs	USD
600056A	¾" press union	9.7	5.1	<b>2,972.00</b>
600066A 001	1" press union, ¾" body	9.7	5.2	<b>3,084.00</b>
600066A	1" press union	21	7.3	<b>3,197.00</b>
600076A	1¼" press union	24	8.2	<b>3,252.00</b>
600086A	1½" press union	34	21	<b>3,767.00</b>
600096A	2" press union	48	22	<b>3,989.00</b>



**6000 LEGIOMIX® flange**

Electronic mixing valve with optional selectable programs for thermal disinfection of hot water recirculation system to kill Legionella bacteria.  
 Power: 24 VAC +/- 10% - 50/60 Hz - 6 VA. 115/24 VAC transformer included.  
 Adjustment temperature range: 70°—185°F.  
 Disinfection temperature range: 100°—185°F.  
 Max body pressure rating (static): 230 psi.  
 Max operating pressure: 150 psi.  
 Max. inlet temperature: 212°F.

Code	Description	Cv	Lbs	USD
600060A	2½" ANSI 150 flanges	105	30	<b>13,462.00</b>
600080A	3" ANSI 150 flanges	120	42	<b>14,250.00</b>

**The LEGIOMIX® includes:**

- Three-way ball valve.
- 3-wire floating control actuator.
- Controller/user interface with DIN rail mounting bracket.
- Mixed outlet temperature sensor/probe.
- Return temperature sensor/probe.
- Mixed outlet temperature gauge.



Size	Recommended Flow Rates (gpm/lpm)						
	¾"	1"	1¼"	1½"	2"	2½"	3"
Minimum flow*	2.2 / 8.3	3.1 / 12	4.4 / 17	6.6 / 25	8.8 / 33	17 / 64	22 / 83
Design flow**	27 / 102	58 / 220	66 / 250	93 / 352	131 / 495	288 / 1,090	329 / 1,245
Flow at 20 psid	43 / 172	94 / 356	107 / 405	152 / 575	215 / 814	470 / 1,780	537 / 2,033
Cv	9.7	21	24	34	48	105	120

\*To ensure stable operation and ± 3° F accuracy. Minimum flow rate is 0 gpm when recirculation flow rate is greater than or equal to the valve size minimum flow rating.  
 \*\*Suggested maximum flow rate for optimum modulating control (at 7.5 psid pressure drop).

**ACCESSORIES AND REPLACEMENT**



Replacement mixed temp sensor.

Code	Description	Lbs	USD
<b>F69807</b>	Fits 1" and 1¼" valve	1.0	<b>66.30</b>



Replacement mixed temp sensor.

Code	Description	Lbs	USD
<b>F69804</b>	Fits 1½" and 2" valve	1.0	<b>94.30</b>



Replacement recirculation sensor.

Code	Description	Lbs	USD
<b>F69591</b>	Replacement recirculation sensor	1.0	<b>84.20</b>



Replacement controller.

Code	Description	Lbs	USD
<b>F000962</b>	Replacement controller	1.5	<b>1,890.00</b>



Replacement actuator.

Code	Description	Lbs	USD
<b>645114</b>	Replacement actuator	1.0	<b>473.00</b>



Replacement transformer.

Code	Description	Lbs	USD
<b>NA10759</b>	Plug-in transformer 20 VA	1.0	<b>40.60</b>



LEGIOMIX® parts bag assembly.

Code	Description	Lbs	USD
<b>R0001397</b>	Bag assembly	0.2	<b>86.50</b>



Replacement temp gauge.

Code	Description	Lbs	USD
<b>R19101</b>	Replacement temp gauge	0.3	<b>23.00</b>



Modbus-to-BACnet gateway  
Converts LEGIOMIX® controller Modbus (RS-485 serial) output communication to BACnet IP or MSTP communication.

Code	Description	Lbs	USD
<b>755052</b>	Modbus-to-BACnet gateway	1.2	<b>2,007.00</b>



Inlet check valve assembly for installing on 6000 Series valve body (if required). Stainless steel body. No Lead. Ordered separately, field installed. 2 required per valve.

Code	Description	Lbs	USD
<b>NA10366</b>	Check valve assembly 1" and 1¼"	1.0	<b>103.00</b>
<b>NA10367</b>	Check valve assembly 1½" & 2"	1.5	<b>228.00</b>



Replacement body includes gauge adapter assembly. See fitting selection table in Section 8.

Code	Description	Lbs	USD
<b>NA10758</b>	Body, gauge adapter (¾" valve)	3.5	<b>484.00</b>
<b>NA10615</b>	Body, gauge adapter (1", 1¼" valves)	5.1	<b>546.00</b>
<b>NA10616</b>	Body, gauge adapter (1½", 2" valves)	11	<b>800.00</b>

Replacement controller battery.



Code	Description	Lbs	USD
<b>F69888</b>	Replacement controller battery	0.1	<b>47.50</b>

6A

**ELECTRONIC MIXING VALVES FOR PLUMBING**



**6000 LEGIOMIX® Station**

Electronic mixing valve pre-packaged in a convenient wall mount configuration. 100% factory tested for plug-and-play in a packaged wall mount configuration.

Station assembly includes pre-piped 3-way mixing valve with union connections, serviceable check valves, a recirculation connection and isolation valves for fast and simple installation, all mounted on welded, powder-coat painted steel strut. The LEGIOMIX® controller/user interface with DIN rail mounting bracket is pre-mounted and pre-wired and includes a return water temperature sensor. Simply wall mount the assembly, hook up the hot and cold water supplies, the mixed outlet and the recirculation circuit. Plug in 120/24 VAC transformer with 20 ft cable included.

Code	Description	Cv	Lbs	USD
600066AS	1" copper wall-mount station	8.0	130	<b>9,922.00</b>
600076AS	1¼" copper wall-mount station	9.0	148	<b>11,274.00</b>
600086AS	1½" copper wall-mount station	20	219	<b>14,269.00</b>
600096AS	2" copper wall-mount station	38	248	<b>16,196.00</b>
600060AS	2½" copper wall-mount station	43	250	<b>18,522.00</b>

**Construction details**

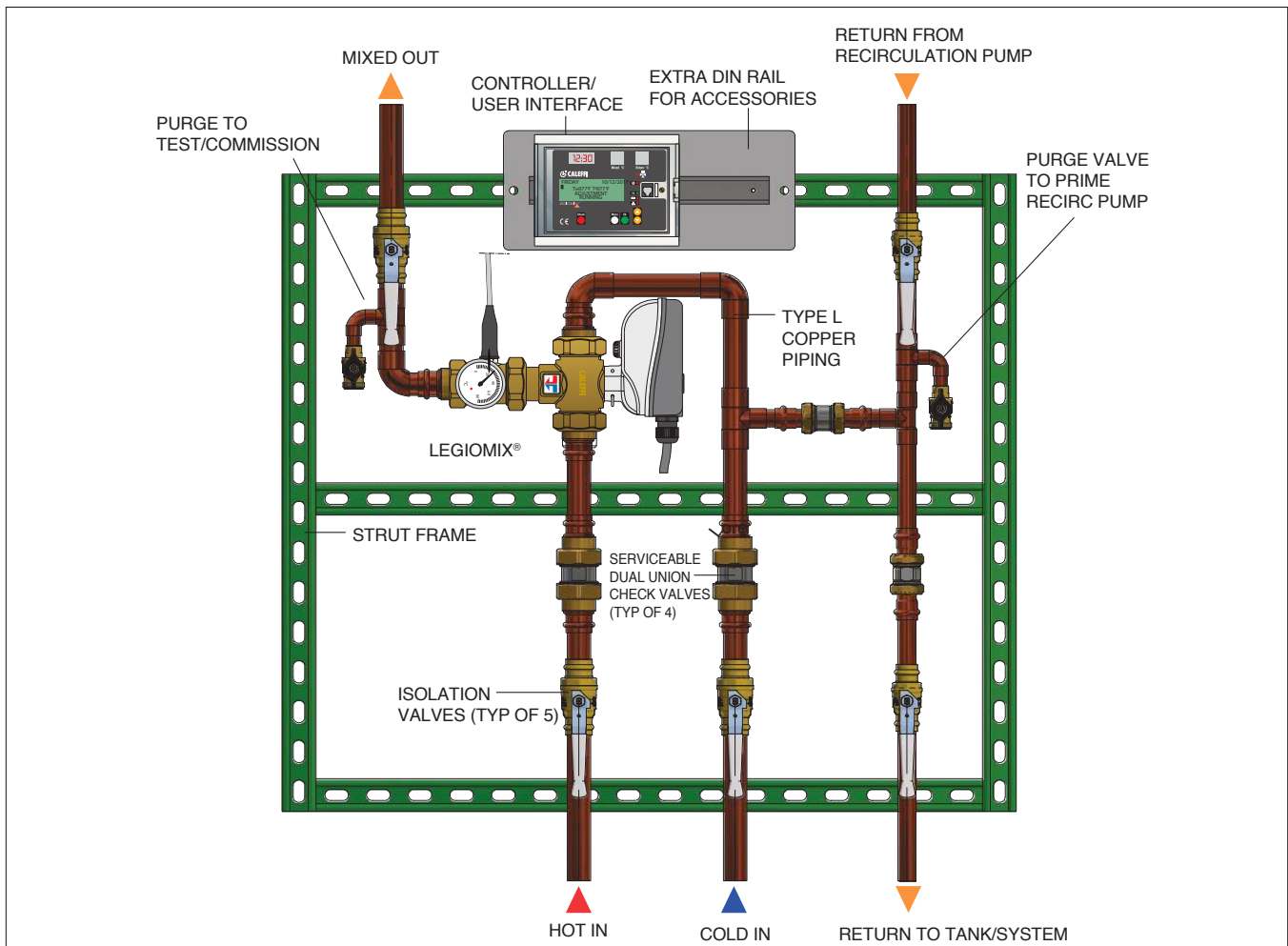



**THERMOSTATIC MIXING VALVE KITS FOR DOMESTIC WATER HEATERS**



**520 TankMixer™**

Adjustment temperature range: 95° – 150°F.  
 Max. working pressure (static): 150 psi.  
 Max. working pressure (dynamic): 75 psi.  
 Max. inlet temperature: 195°F.  
 Minimum flow for optimum performance: 0.5 GPM (0 GPM with recirculation).  
 Max flow for optimum performance: 9 gpm.  
 Tank: 3/4" NPT female union connections.  
 System: 3/4" NPT M, press or sweat union connections.

Code	Description	Cv	Lbs	USD
520500AX	3/4" NPT male union system connections	2.0	2.4	<b>287.00</b>
520506AX	3/4" press union system connections	2.0	2.4	<b>328.00</b>
520509AX	3/4" sweat union system connections	2.0	2.4	<b>277.00</b>



**520 TankMixer™ with gauge**

Adjustment temperature range: 95° – 150°F.  
 Max. working pressure (static): 150 psi.  
 Max. working pressure (dynamic): 75 psi.  
 Max. inlet temperature: 195°F.  
 Gauge scale: 30° – 210°F.  
 Gauge accuracy: ± 6°F.  
 Gauge dial: 2" diameter.  
 Minimum flow for optimum performance: 0.5 GPM (0 GPM with recirculation).  
 Max flow for optimum performance: 9 gpm.  
 Tank: 3/4" NPT female union connections.  
 System: 3/4" NPT M, press or sweat union connections.

Code	Description	Cv	Lbs	USD
520510AX	3/4" NPT male union system connections	2.0	2.9	<b>328.00</b>
520516AX	3/4" press union system connections	2.0	2.9	<b>369.00</b>
520519AX	3/4" sweat union system connections	2.0	2.9	<b>318.00</b>

**Construction details TankMixer™**

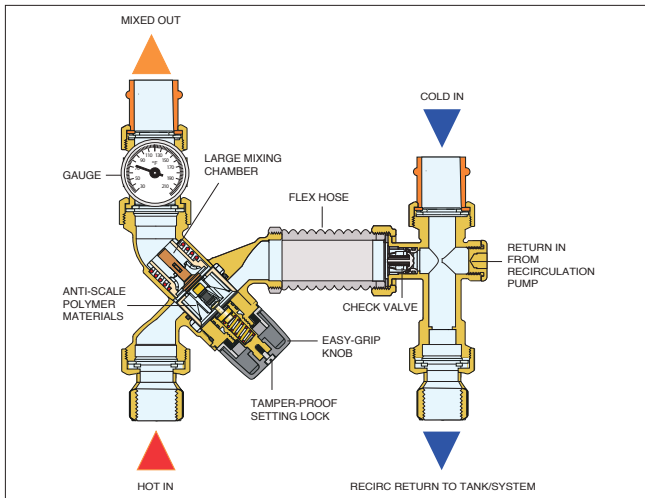

**520 TankMixer™ with Tankless Heater Service Valve Kit**

For use on tankless water heaters and combi boilers, the kit includes the 520 TankMixer for tempered water control and the 290 Series service valves for fill/flush/drain functionality. A pressure relief valve and temperature gauge are included.

**Full details on the 290 Series are shown in section 6D**

Code	Description	Cv	Lbs	USD
290516A	3/4" press	2.0	5.0	<b>475.00</b>
290519A	3/4" sweat	2.0	5.0	<b>456.00</b>
290510A	3/4" FNPT	2.0	5.0	<b>467.00</b>
290517A	3/4" PEX crimp	2.0	5.0	<b>456.00</b>
290518A	3/4" PEX exp	2.0	5.0	<b>456.00</b>

**Construction details TankMixer™ Kit**

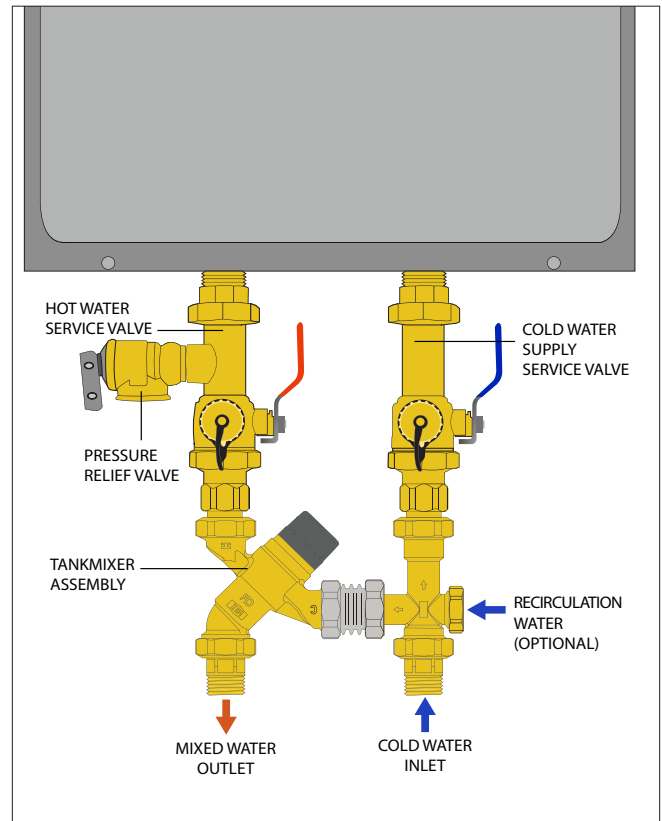

The TankMixer Kit takes your tankless water heater to the next level with service valves that allow for easy flushing of the heat exchanger. With the included pressure relief valve and TankMixer mixing valve you can also ensure safe operation of your tankless water heater and accurate temperature control to your fixtures.

Meets requirements of NSF/ANSI/CAN 372. Certified to ASSE 1017, CSA B125.3, UPC, IPC, Low Lead Laws and listed by ICC-ES for use in accordance with the U.S. and Canadian plumbing codes.

# THERMOSETTER™ THERMAL BALANCING SET IT AND FORGET IT



**ThermoSetter™** thermal balancing valves maintain precise temperature in recirculation return piping using state-of-the-art modulating control. **Setup is simple** and safe with an easy-to-read, lockable temperature adjustment dial. Enjoy **ease of maintenance** with serviceable cartridge. Models with bypass cartridges available for systems that provide thermal disinfection to control **Legionella bacteria**. Factory assemblies with isolation and check valves are available. **Approvals include compliance with the U.S. and Canadian plumbing codes. CALEFFI GUARANTEED.**



# BALANCING VALVES FOR PLUMBING AND HYDRONICS

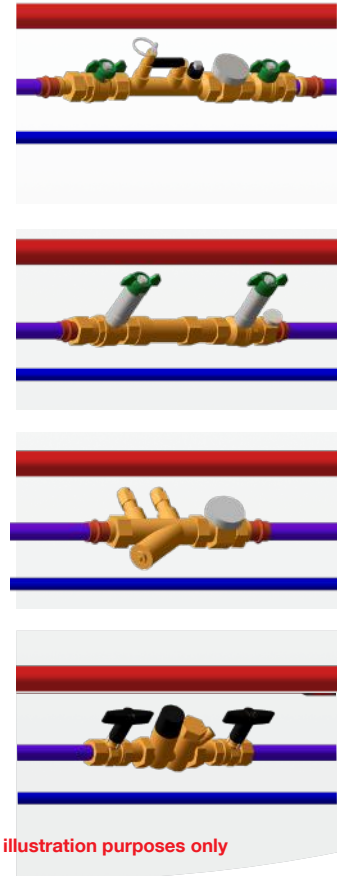
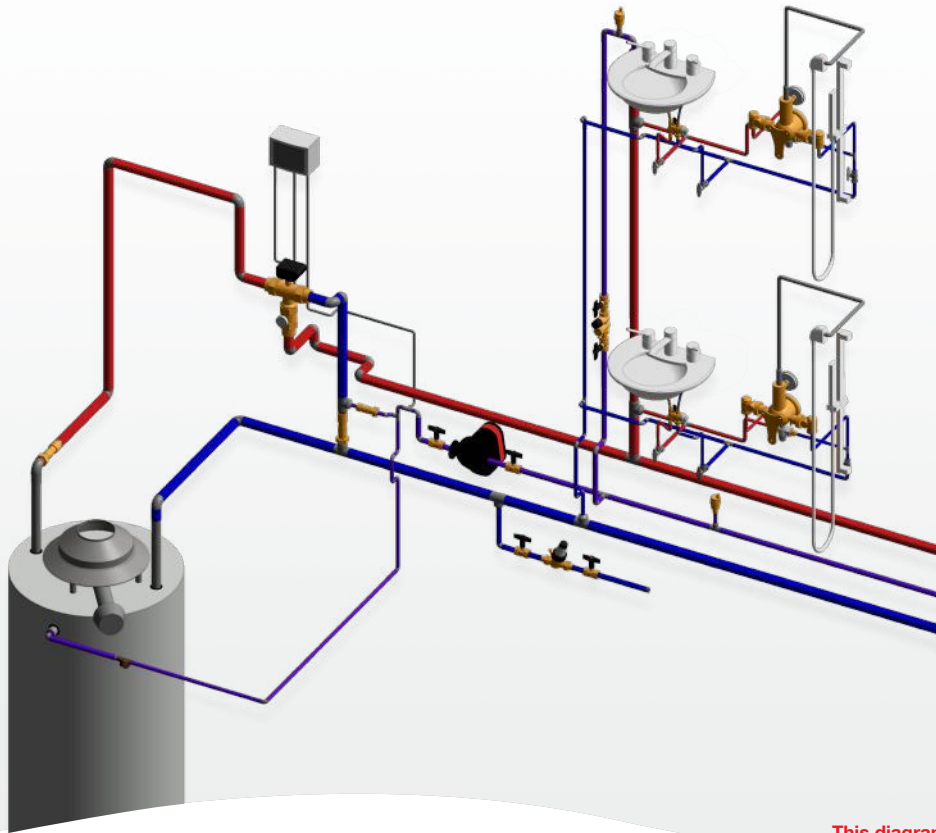

This diagram is for illustration purposes only



 **BIM**  
bim.caleffi.com

## PRODUCTS INCLUDED IN SECTION

- Static balancing valves with built-in flowmeter for plumbing
- Static balancing valves with built-in flowmeter for hydronics
- Static balancing valves, fixed orifice, for plumbing and hydronics
- Static balancing valves, variable orifice, for plumbing and hydronics
- Dynamic balancing valves for plumbing and hydronics
- Dynamic balancing valves for hydronics
- Thermal balancing valves for plumbing

**STATIC BALANCING VALVES WITH BUILT-IN FLOWMETER FOR PLUMBING**



**132 QuickSetter+™ sweat**

Balancing valve with flow meter.  
Direct reading of flow rate.  
DZR low-lead brass.  
Inlet flow check valve.

Code	Description	Flow scale (gpm)	Lbs	USD
132439AFC	½" sweat union	0.5—1.8	1.8	265.00
132539AFC	¾" sweat union	0.5—1.8	2.0	276.00
132639AFC	1" sweat union	0.5—1.8	2.4	305.00
132559AFC	¾" sweat union	2.0—7.0	2.0	276.00
132659AFC	1" sweat union	2.0—7.0	2.4	305.00
132459AFC	½" sweat union	2.0—7.0	1.8	265.00



**132 QuickSetter+™ sweat**

Balancing valve with and temperature gauge.  
Direct reading of flow rate.  
DZR low-lead brass.  
Inlet flow check valve.  
Dual scale: 30° — 210°F (0° — 100°C).  
Gauge accuracy: ± 6°F.

Code	Description	Flow scale (gpm)	Lbs	USD
132438AFC	½" sweat union	0.5—1.8	2.4	304.00
132538AFC	¾" sweat union	0.5—1.8	2.2	316.00
132638AFC	1" sweat union	0.5—1.8	2.8	342.00
132458AFC	½" sweat union	2.0—7.0	2.4	304.00
132558AFC	¾" sweat union	2.0—7.0	2.2	316.00
132658AFC	1" sweat union	2.0—7.0	2.8	342.00



**132 QuickSetter+™ press**

Balancing valve with flow meter.  
Direct reading of flow rate.  
DZR low-lead brass.  
Inlet flow check valve.

Code	Description	Flow scale (gpm)	Lbs	USD
132436AFC	½" press union	0.5—1.8	1.8	305.00
132536AFC	¾" press union	0.5—1.8	1.8	317.00
132636AFC	1" press union	0.5—1.8	2.2	351.00
132456AFC	½" press union	2.0—7.0	1.8	305.00
132556AFC	¾" press union	2.0—7.0	1.8	317.00
132656AFC	1" press union	2.0—7.0	2.2	351.00



**132 QuickSetter+™ press**

Balancing valve with and temperature gauge.  
Direct reading of flow rate.  
DZR low-lead brass.  
Inlet flow check valve.  
Dual scale: 30° — 210°F (0° — 100°C).  
Gauge accuracy: ± 6°F.

Code	Description	Flow scale (gpm)	Lbs	USD
132437AFC	½" press union	0.5—1.8	1.8	349.00
132537AFC	¾" press union	0.5—1.8	2.2	364.00
132637AFC	1" press union	0.5—1.8	2.6	392.00
132457AFC	½" press union	2.0—7.0	1.8	349.00
132557AFC	¾" press union	2.0—7.0	2.2	364.00
132657AFC	1" press union	2.0—7.0	2.6	392.00



**132 QuickSetter+™ PEX**

Balancing valve with flow meter.  
Direct reading of flow rate.  
DZR low-lead brass.  
Inlet flow check valve.  
PEX crimp: ASTM F1807  
PEX expansion: ASTM F1960

Code	Description	Flow scale (gpm)	Lbs	USD
132434AFC	½" PEX crimp union	0.5—1.8	1.8	265.00
132432AFC	½" PEX expansion union	0.5—1.8	1.8	265.00
132534AFC	¾" PEX crimp union	0.5—1.8	2.0	276.00
132532AFC	¾" PEX expansion union	0.5—1.8	2.0	276.00
132634AFC	1" PEX crimp union	0.5—1.8	2.2	319.00
132632AFC	1" PEX expansion union	0.5—1.8	2.2	319.00
132454AFC	½" PEX crimp union	2.0—7.0	1.8	265.00
132452AFC	½" PEX expansion union	2.0—7.0	1.8	265.00
132554AFC	¾" PEX crimp union	2.0—7.0	2.0	276.00
132552AFC	¾" PEX expansion union	2.0—7.0	2.0	276.00
132654AFC	1" PEX crimp union	2.0—7.0	2.2	319.00
132652AFC	1" PEX expansion union	2.0—7.0	2.2	319.00



**132 QuickSetter+™ PEX**

Balancing valve with and temperature gauge.  
Direct reading of flow rate.  
DZR low-lead brass.  
Inlet flow check valve.  
PEX crimp: ASTM F1807  
PEX expansion: ASTM F1960

Code	Description	Flow scale (gpm)	Lbs	USD
132435AFC	½" PEX crimp union	0.5—1.8	2.2	304.00
132433AFC	½" PEX expansion union	0.5—1.8	2.2	304.00
132535AFC	¾" PEX crimp union	0.5—1.8	2.4	316.00
132533AFC	¾" PEX expansion union	0.5—1.8	2.4	316.00
132635AFC	1" PEX crimp union	0.5—1.8	2.6	357.00
132633AFC	1" PEX expansion union	0.5—1.8	2.6	357.00
132455AFC	½" PEX crimp union	2.0—7.0	2.2	304.00
132453AFC	½" PEX expansion union	2.0—7.0	2.2	304.00
132555AFC	¾" PEX crimp union	2.0—7.0	2.4	316.00
132553AFC	¾" PEX expansion union	2.0—7.0	2.4	316.00
132655AFC	1" PEX crimp union	2.0—7.0	2.6	357.00
132653AFC	1" PEX expansion union	2.0—7.0	2.6	357.00

Complies with NSF/ANSI/CAN 372-2000, low lead laws, for use in accordance with the U.S. and Canadian plumbing codes.

**STATIC BALANCING VALVES WITH BUILT-IN FLOWMETER FOR HYDRONICS**



**132 QuickSetter™ press**

Balancing valve with flow meter.  
Direct reading of flow rate.  
No sight gauge clouding or scaling.  
Brass valve body and flow meter.  
Max. working pressure: 150 psi.  
Temperature range: 14°–230°F.  
Max. percentage of glycol: 50%.  
Insulation jacket included.



**132 QuickSetter™**

Balancing valve with flow meter.  
Direct reading of flow rate.  
No sight gauge clouding or scaling.  
Brass valve body and flow meter.  
Max. working pressure: 150 psi.  
Temperature range: 14°–230°F.  
Max. percentage of glycol: 50%.  
Insulation jacket included.

Code	Description	Flow scale (gpm)	Lbs	USD
132436A	½" press	0.5 – 1.8	2.2	226.00
132556A	¾" press	2.0 – 7.0	2.0	254.00
132666A	1" press	3.0 – 10	2.4	298.00
132776A	1¼" press	5.0 – 19	2.8	394.00
132886A	1½" press	8.0 – 32	3.4	469.00
132996A	2" press	12 – 50	4.4	574.00

Code	Description	Flow scale (gpm)	Lbs	USD
132432A	½" FNPT	0.5 – 1.8	2.0	210.00
132552A	¾" FNPT	2.0 – 7.0	1.8	226.00
132662A	1" FNPT	3.0 – 10	2.4	264.00
132772A	1¼" FNPT	5.0 – 19	2.8	351.00
132882A	1½" FNPT	8.0 – 32	3.4	416.00
132992A	2" FNPT	12 – 50	4.4	509.00

**STATIC BALANCING VALVES WITH BUILT-IN FLOWMETER**

Construction details for QuickSetter+™

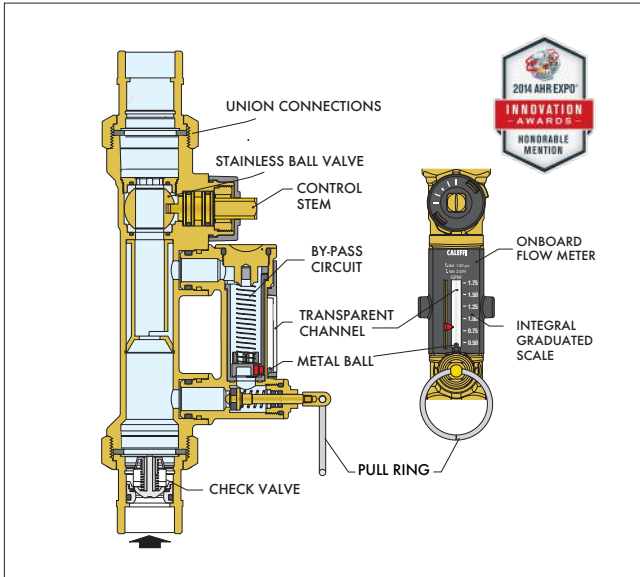

Connection size	Flow rate (gpm)	Fully open Cv
½"	0.5 - 1.8	1.0
¾"	0.5 - 1.8	1.0
1"	0.5 - 1.8	1.0
½"	2.0 - 7.0	6.3
¾"	2.0 - 7.0	6.3
1"	2.0 - 7.0	6.3

Construction details for QuickSetter™

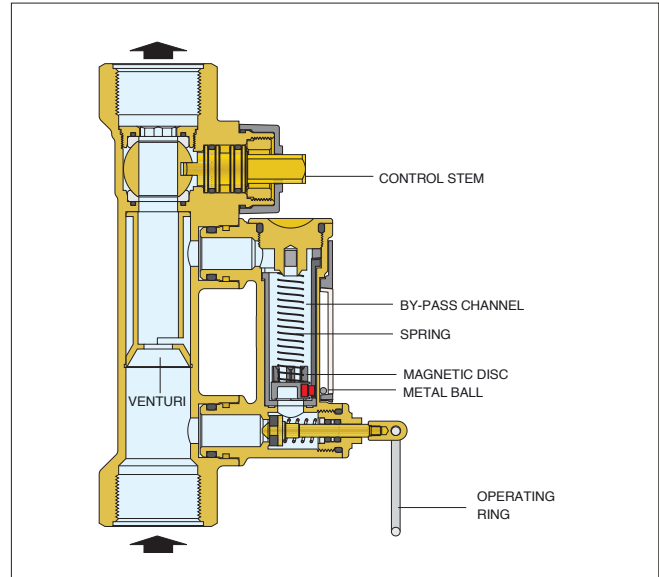

Connection size	Flow rate (gpm)	Fully open Cv
½"	0.5 - 1.8	3.0
¾"	2.0 - 7.0	6.3
1"	3.0 - 10	8.3
1¼"	5.0 - 19	15
1½"	8.0 - 32	32
2"	12 - 50	54

**ACCESSORIES**



See 290030 and NA108 isolation valves in Section 6D.

Code	Description	Lbs	USD
<b>290030</b>	Isolation ball valve 1" M x 1" F union	1.0	<b>47.60</b>
<b>NA10815</b>	Stem extension for 290030	0.2	<b>27.10</b>



**NA108**

NPT full port ball valves with extended operator handle for insulated or bare pipes. For use with hot or cold water piping in plumbing or hydronic applications. High strength forged low lead brass. Blowout-proof stem with dual o-ring seals. Pressure rating 600 WOG. Temperature rating -4° — 366°F.

Code	Description	Lbs	USD
<b>NA10824</b>	½" FNPT ball valve low lead	0.4	<b>38.40</b>
<b>NA10825</b>	¾" FNPT ball valve low lead	0.6	<b>47.10</b>
<b>NA10826</b>	1" FNPT ball valve low lead	1.0	<b>61.10</b>
<b>NA10827</b>	1¼" FNPT ball valve low lead	1.6	<b>102.00</b>
<b>NA10828</b>	1½" FNPT ball valve low lead	1.9	<b>129.00</b>
<b>NA10829</b>	2" FNPT ball valve low lead	3.0	<b>314.00</b>



Replacement flow meter.

Code	Description	Lbs	USD
<b>F0000940</b>	Replacement flowmeter 0.5 to 1.75 GPM	0.2	<b>116.00</b>
<b>F0000941</b>	Replacement flowmeter 2.0 to 7.0 GPM	0.2	<b>116.00</b>
<b>F0000942</b>	Replacement flowmeter 3.0 to 10 GPM	0.2	<b>116.00</b>
<b>F0000943</b>	Replacement flowmeter 5.0 to 19 GPM	0.2	<b>123.00</b>
<b>F0000944</b>	Replacement flowmeter 8.0 to 32 GPM	0.2	<b>123.00</b>
<b>F0000945</b>	Replacement flowmeter 12 to 50 GPM	0.2	<b>123.00</b>
<b>F0000946</b>	Replacement flowmeter 30 to 105GPM	0.2	<b>129.00</b>
<b>F0000947</b>	Replacement flowmeter 38 to 148 GPM	0.2	<b>129.00</b>
<b>F0000948</b>	Replacement flowmeter 55 to 210 GPM	0.2	<b>129.00</b>
<b>F19346</b>	Replacement by-pass valve stem*	0.2	<b>42.50</b>

\*With operating ring



QuickSetter+™ Insulation sleeve for valve and fitting on each end.

Code	Description	Lbs	USD
<b>F0000926</b>	For models with temperature gauge	0.1	<b>42.40</b>
<b>112001</b>	For models without temperature gauge	0.1	<b>41.80</b>



QuickSetter+™ replacement body. See fitting section table in Section 8.

Code	Description	Lbs	USD
<b>132637</b>	0.5 - 1.8 GPM	1.0	<b>210.00</b>
<b>132657</b>	2.0 - 7.0 GPM	1.0	<b>221.00</b>

**STATIC BALANCING VALVES WITH BUILT-IN FLOWMETER FOR HYDRONICS**



**132 QuickSetter™ flange**

Balancing valve with flow meter. Direct reading of flow rate. ANSI 125 flanged cast iron body. Brass flow meter. Max. working pressure: 150 psi. Temperature range: 14° — 230°F. Max. percentage of glycol: 50%.

Code	Description	Flow scale (gpm)	Lbs	USD
<b>132060A</b>	2½" ANSI flange	30—105	35	<b>1,256.00</b>
<b>132080A</b>	3" ANSI flange	38—148	62	<b>1,675.00</b>
<b>132100A</b>	4" ANSI flange	55—210	67	<b>2,556.00</b>

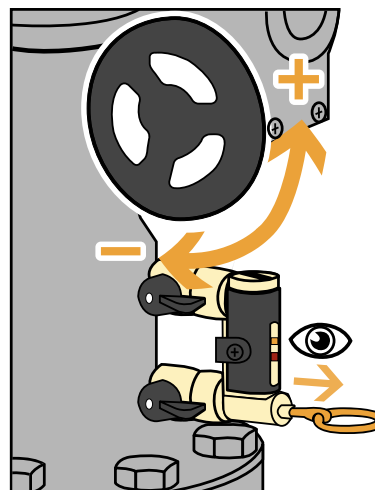

The 132 Series balancing valve accurately sets the flow rate of heating and cooling transfer fluid. The flow meter is housed in a bypass circuit on the valve body and can be shut off during normal operation. The flow meter permits fast and easy circuit balancing without added differential pressure gauges and reference charts.

**STATIC BALANCING VALVES, FIXED ORIFICE, FOR PLUMBING AND HYDRONICS**

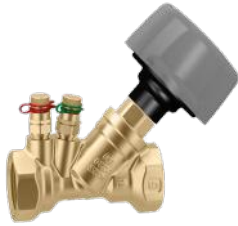

**130 Flo-Set™ Fixed Orifice Balancing Valve**

Fixed orifice.  
Multi-turn adjustment range.  
Memory stop feature.  
Max. working pressure: 232 psi  
Working temperature range: -4°— 250°F  
Number of adjustment turns: 6  
DZR Low-lead brass body.  
Stainless steel valve plug.  
Teflon® stem guide bearing.

Code	Description	Max Cv	Lbs	USD
<b>130400A</b>	½" NPT female	3.7	1.0	<b>142.00</b>
<b>130500A</b>	¾" NPT female	5.1	1.2	<b>156.00</b>
<b>130600A</b>	1" NPT female	8.8	1.5	<b>185.00</b>
<b>130700A</b>	1¼" NPT female	14	2.0	<b>232.00</b>
<b>130800A</b>	1½" NPT female	20	2.3	<b>288.00</b>
<b>130900A</b>	2" NPT female	31	2.5	<b>384.00</b>

**Venturi flow rate measurement device**

The 130 Series valves are equipped with a flow rate measurement device based on the Venturi effect. The device is incorporated in the body of the valve upstream of the valve plug.



Insulation shell fits 130 Series balancing valves.

Code	Description	Lbs	USD
<b>CBN130400</b>	fits ½" NPT	0.1	<b>31.20</b>
<b>CBN130500</b>	fits ¾" NPT	0.1	<b>33.90</b>
<b>CBN130600</b>	fits 1" NPT	0.1	<b>40.70</b>
<b>CBN130700</b>	fits 1¼" NPT	0.1	<b>50.70</b>
<b>CBN130800</b>	fits 1½" NPT	0.1	<b>63.30</b>
<b>CBN130900</b>	fits 2" NPT	0.1	<b>84.40</b>

**Operating Principal**

The 130 Series balancing valve is a hydraulic device that controls the flow rate of a fluid. Turning the knob moves a plug within the fluid stream which varies the flow rate. The flow rate is determined according to the pressure drop value measured by a differential pressure meter connected to the pressure test ports.

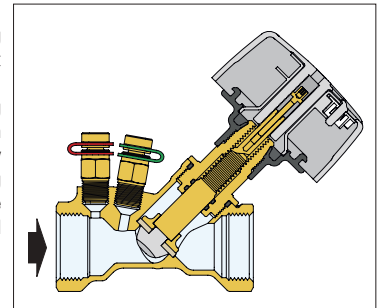

6B

**STATIC BALANCING VALVES, VARIABLE ORIFICE, FOR PLUMBING AND HYDRONICS**



**142 Flo-Set™ Variable Orifice Balancing Valve**

Memory stop feature.  
Characterized plug for smooth adjustment.  
Maximum working pressure: 232 psi.  
Working temperature range: 14°—250°F.  
DZR low-lead brass body.  
Meets requirements of ANSI/NSF 372-2011.  
Certified to Low Lead Laws and listed by ICC-ES for use in accordance with the U.S. and Canadian plumbing codes.

Code	Description	Max Cv	Lbs	USD
<b>142241A</b>	½" NPT female	3.4	1.0	<b>111.00</b>
<b>142251A</b>	¾" NPT female	5.0	1.2	<b>119.00</b>
<b>142261A</b>	1" NPT female	7.5	1.5	<b>161.00</b>
<b>142271A</b>	1¼" NPT female	13	2.3	<b>231.00</b>
<b>142281A</b>	1½" NPT female	17	3.0	<b>258.00</b>
<b>142291A</b>	2" NPT female	22	3.5	<b>330.00</b>



Insulation shell fits 142 Series balancing valves.

Code	Description	Lbs	USD
<b>CBN142241A</b>	fits ½" NPT	0.1	<b>28.60</b>
<b>CBN142251A</b>	fits ¾" NPT	0.1	<b>30.40</b>
<b>CBN142261A</b>	fits 1" NPT	0.1	<b>41.40</b>
<b>CBN142271A</b>	fits 1¼" NPT	0.1	<b>59.10</b>
<b>CBN142281A</b>	fits 1½" NPT	0.1	<b>66.50</b>

**Operating Principal**

The 142 Series balancing valve is a hydraulic device that controls the flow rate of a fluid. Turning the knob moves a plug within the fluid stream which varies the flow rate. The flow rate is determined according to the pressure drop value measured by a differential pressure meter connected to the pressure test ports and the adjustment knob position.

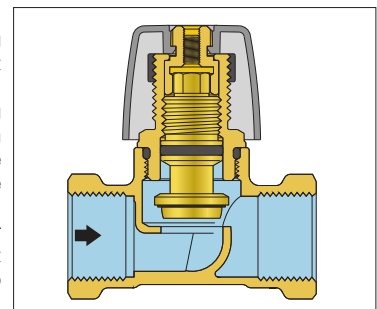

Meets requirements of ANSI/NSF 372. Certified to Low Lead Laws and listed by ICC-ES for use in accordance with the U.S. and Canadian plumbing codes.

**DYNAMIC BALANCING VALVES FOR PLUMBING AND HYDRONICS**

**NEW**



**128 FlowCal+™ sweat**

Y-body automatic balancing valves. Patented anti-scale, low noise polymer FlowCal™ cartridge.  
 DZR low-lead brass bodies.  
 PT ports included.  
 Max. working pressure: 400 psi.  
 Temperature range: 32°–212° F.  
 Max. percentage of glycol: 50%.  
 Flow rate range: 0.35 to 10 GPM.  
 Flow accuracy: +/- 10%.  
 Models with 2" diameter temperature gauge.  
 Select desired flow rate on **page 76** to complete full part number.

Code	Description	Lbs	USD
128448AFC***	1/2" sweat, PT ports, check	2.0	162.00
128458AFC***	3/4" sweat, PT ports, check	2.0	189.00
128468AFC***	1" sweat, PT ports, check	2.2	198.00

**NEW**



**128 FlowCal+™ PEX**

Y-body automatic balancing valves. Patented anti-scale, low noise polymer FlowCal™ cartridge.  
 DZR low-lead brass bodies.  
 PT ports included.  
 Max. working pressure: 400 psi.  
 Temperature range: 32°–212° F.  
 Max. percentage of glycol: 50%.  
 Flow rate range: 0.35 to 10 GPM.  
 Flow accuracy: +/- 10%.  
 PEX crimp: ASTM F1807.  
 PEX expansion: ASTM F1960.  
 Models with 2" diameter temperature gauge.  
 Select desired flow rate on **page 76** to complete full part number.

Code	Description	Lbs	USD
128445AFC***	1/2" PEX crimp, PT ports, check	2.0	162.00
128455AFC***	3/4" PEX crimp, PT ports, check	2.0	189.00
128465AFC***	1" PEX crimp, PT ports, check	2.2	198.00
128443AFC***	1/2" PEX expansion, PT ports, check	2.0	162.00
128453AFC***	3/4" PEX expansion, PT ports, check	2.0	189.00
128463AFC***	1" PEX expansion, PT ports, check	2.2	198.00

**NEW**



**128 FlowCal+™ NPT**

Y-body automatic balancing valves. Patented anti-scale, low noise polymer FlowCal™ cartridge.  
 DZR low-lead brass bodies.  
 PT ports included.  
 Max. working pressure: 400 psi.  
 Temperature range: 32°–212° F.  
 Max. percentage of glycol: 50%.  
 Flow rate range: 0.35 to 10 GPM.  
 Flow accuracy: +/- 10%.  
 Models with 2" diameter temperature gauge.  
 Select desired flow rate on **page 76** to complete full part number.

Code	Description	Lbs	USD
128440AFC***	1/2" NPT male, PT ports, check	2.0	167.00
128450AFC***	3/4" NPT male, PT ports, check	1.8	194.00
128460AFC***	1" NPT male, PT ports, check	2.0	200.00

**NEW**



**128 FlowCal+™ press**

Y-body automatic balancing valves. Patented anti-scale, low noise polymer FlowCal™ cartridge.  
 DZR low-lead brass bodies.  
 PT ports included.  
 Max. working pressure: 400 psi.  
 Temperature range: 32°–212° F.  
 Max. percentage of glycol: 50%.  
 Flow rate range: 0.35 to 10 GPM.  
 Flow accuracy: +/- 10%.  
 Models with 2" diameter temperature gauge.  
 Select desired flow rate on **page 76** to complete full part number.

Code	Description	Lbs	USD
128447AFC***	1/2" press, PT ports, check	2.0	184.00
128457AFC***	3/4" press, PT ports, check	2.0	207.00
128467AFC***	1" press, PT ports, check	2.2	215.00

**Construction details**

The Y-body 128 Series FlowCal uses the same flow cartridges as the 127 Series FlowCal. Because the body can remain in the piping, the Y-body simplifies serviceability and cartridge changeout. The 128 Series includes factory installed PT ports.

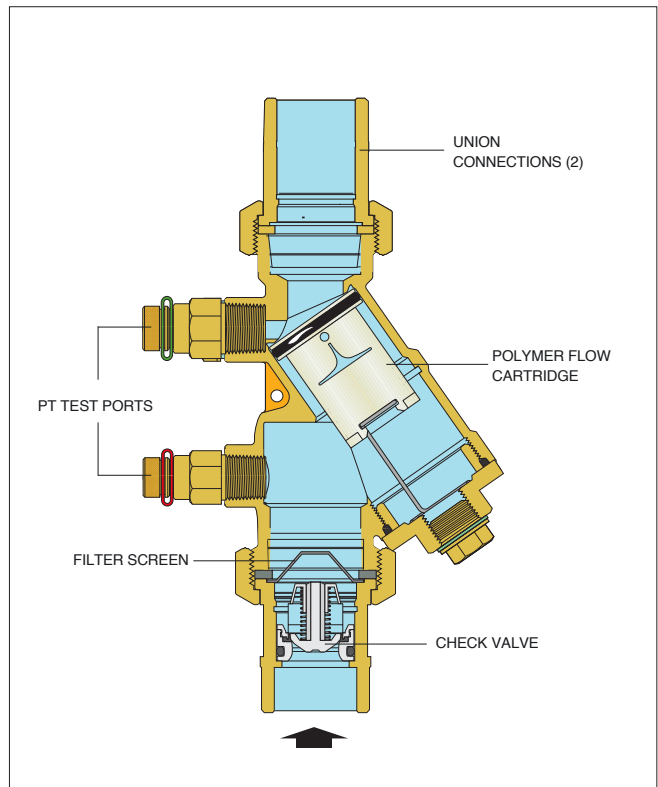

Complies with NSF/ANSI/CAN 372, low lead laws, for use in accordance with the U.S. and Canadian plumbing codes. U.S. Patent 7,246,635 B2.



**DYNAMIC BALANCING VALVES FOR PLUMBING AND HYDRONICS**

**NEW**



**128 FlowCal+™ sweat**

Y-body automatic balancing valves. Patented anti-scale, low noise polymer FlowCal™ cartridge.  
DZR low-lead brass bodies.  
PT ports included.  
Max. working pressure: 400 psi.  
Temperature range: 32°–212° F.  
Max. percentage of glycol: 50%.  
Flow rate range: 0.35 to 10 GPM.  
Flow accuracy: +/- 10%.  
Select desired flow rate on **page 76** to complete full part number.

Code	Description	Lbs	USD
128449AFC***	1/2" sweat, PT ports, check	1.8	130.00
128459AFC***	3/4" sweat, PT ports, check	1.8	137.00
128469AFC***	1" sweat, PT ports, check	2.0	165.00

**NEW**



**128 FlowCal+™ PEX**

Y-body automatic balancing valves. Patented anti-scale, low noise polymer FlowCal™ cartridge.  
DZR low-lead brass bodies.  
PT ports included.  
Max. working pressure: 400 psi.  
Temperature range: 32°–212° F.  
Max. percentage of glycol: 50%.  
Flow rate range: 0.35 to 10 GPM.  
Flow accuracy: +/- 10%.  
PEX crimp: ASTM F1807.  
PEX expansion: ASTM F1960.  
Select desired flow rate on **page 76** to complete full part number.

Code	Description	Lbs	USD
128444AFC***	1/2" PEX crimp, PT ports, check	1.8	130.00
128454AFC***	3/4" PEX crimp, PT ports, check	1.8	137.00
128464AFC***	1" PEX crimp, PT ports, check	2.0	165.00
128442AFC***	1/2" PEX expansion, PT ports, check	1.8	130.00
128452AFC***	3/4" PEX expansion, PT ports, check	1.8	137.00
128462AFC***	1" PEX expansion, PT ports, check	2.0	165.00

**NEW**



**128 FlowCal+™ NPT**

Y-body automatic balancing valves. Patented anti-scale, low noise polymer FlowCal™ cartridge.  
DZR low-lead brass bodies.  
PT ports included.  
Max. working pressure: 400 psi.  
Temperature range: 32°–212° F.  
Max. percentage of glycol: 50%.  
Flow rate range: 0.35 to 10 GPM.  
Flow accuracy: +/- 10%.  
Select desired flow rate on **page 76** to complete full part number.

Code	Description	Lbs	USD
128441AFC***	1/2" NPT male, PT ports, check	1.8	131.00
128451AFC***	3/4" NPT male, PT ports, check	1.6	138.00
128461AFC***	1" NPT male, PT ports, check	1.8	167.00

**NEW**



**128 FlowCal+™ press**

Y-body automatic balancing valves. Patented anti-scale, low noise polymer FlowCal™ cartridge.  
DZR low-lead brass bodies.  
PT ports included.  
Max. working pressure: 400 psi.  
Temperature range: 32°–212° F.  
Max. percentage of glycol: 50%.  
Flow rate range: 0.35 to 10 GPM.  
Flow accuracy: +/- 10%.  
Select desired flow rate on **page 76** to complete full part number.

Code	Description	Lbs	USD
128446AFC***	1/2" press, PT ports, check	1.8	141.00
128456AFC***	3/4" press, PT ports, check	1.8	155.00
128466AFC***	1" press, PT ports, check	2.0	173.00

**Connecting Device**

Integral pressure temperature ports allow for quick confirmation of differential pressure to ensure that the valve is functioning within its control range.

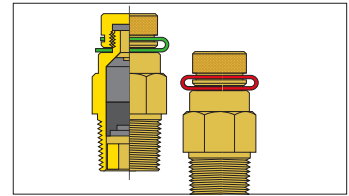

**Replaceable cartridge**

The internal regulator is assembled in the form of a self contained cartridge so as to permit easy removal from the body for inspection or replacement. It is equipped with a special automatic fixing system with wire and an operating ring for fast and safe positioning without using tools.

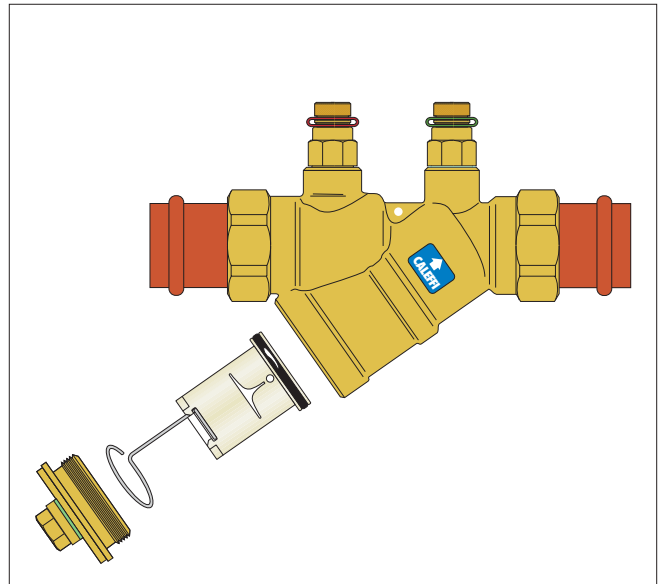

Complies with NSF/ANSI/CAN 372, low lead laws, for use in accordance with the U.S. and Canadian plumbing codes. U.S. Patent 7,246,635 B2.

**DYNAMIC BALANCING VALVES FOR PLUMBING AND HYDRONICS**

**NEW**



**128 FlowCal™ sweat**

Y-body automatic balancing valves. Patented anti-scale, low noise polymer FlowCal™ cartridge.  
 DZR low-lead brass bodies.  
 PT ports included.  
 Max. working pressure: 400 psi.  
 Temperature range: 32°–212° F.  
 Max. percentage of glycol: 50%.  
 Flow rate range: 0.35 to 10 GPM.  
 Flow accuracy: +/- 10%.  
 Select desired flow rate on **page 76** to complete full part number.

Code	Description	Lbs	USD
128549AF***	½" sweat, PT ports	1.8	120.00
128559AF***	¾" sweat, PT ports	2.0	125.00
128569AF***	1" sweat, PT ports	2.2	141.00

**NEW**



**128 FlowCal™ PEX**

Y-body automatic balancing valves. Patented anti-scale, low noise polymer FlowCal™ cartridge.  
 DZR low-lead brass bodies.  
 PT ports included.  
 Max. working pressure: 400 psi.  
 Temperature range: 32°–212° F.  
 Max. percentage of glycol: 50%.  
 Flow rate range: 0.35 to 10 GPM.  
 Flow accuracy: +/- 10%.  
 PEX crimp: ASTM F1807.  
 PEX expansion: ASTM F1960.  
 Select desired flow rate on **page 76** to complete full part number.

Code	Description	Lbs	USD
128544AF***	½" PEX crimp, PT ports	2.0	120.00
128554AF***	¾" PEX crimp, PT ports	2.1	125.00
128564AF***	1" PEX crimp, PT ports	2.2	141.00
128542AF***	½" PEX expansion, PT ports	2.0	120.00
128552AF***	¾" PEX expansion, PT ports	2.1	125.00
128562AF***	1" PEX expansion, PT ports	2.2	141.00

**NEW**



**128 FlowCal™ NPT**

Y-body automatic balancing valves. Patented anti-scale, low noise polymer FlowCal™ cartridge.  
 DZR low-lead brass bodies.  
 PT ports included.  
 Max. working pressure: 400 psi.  
 Temperature range: 32°–212° F.  
 Max. percentage of glycol: 50%.  
 Flow rate range: 0.35 to 10 GPM.  
 Flow accuracy: +/- 10%.  
 Select desired flow rate on **page 76** to complete full part number.

Code	Description	Lbs	USD
128541AF***	½" NPT male, PT ports	2.0	125.00
128551AF***	¾" NPT male, PT ports	2.1	130.00
128561AF***	1" NPT male, PT ports	2.2	145.00

**NEW**



**128 FlowCal™ press**

Y-body automatic balancing valves. Patented anti-scale, low noise polymer FlowCal™ cartridge.  
 DZR low-lead brass bodies.  
 PT ports included.  
 Max. working pressure: 400 psi.  
 Temperature range: 32°–212° F.  
 Max. percentage of glycol: 50%.  
 Flow rate range: 0.35 to 10 GPM.  
 Flow accuracy: +/- 10%.  
 Select desired flow rate on **page 76** to complete full part number.

Code	Description	Lbs	USD
128546AF***	½" press, PT ports	2.0	136.00
128556AF***	¾" press, PT ports	2.1	147.00
128566AF***	1" press, PT ports	2.2	175.00

**Construction details**

The Y-body 128 Series FlowCal uses the same flow cartridges as the 127 Series FlowCal. Because the body can remain in the piping, the Y-body simplifies serviceability and cartridge changeout. The 128 Series includes factory installed PT ports. The FlowCal+ models come with a check valve in the inlet tailpiece, to prevent backward flow in DHW recirculation applications, and are available with or without outlet temperature gauge. The standard FlowCal models do not include a check valve.

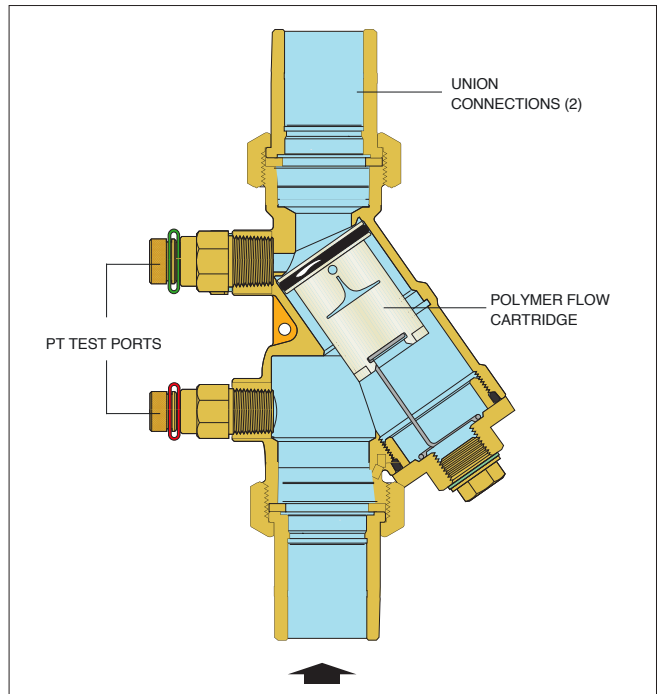

Complies with NSF/ANSI/CAN 372, low lead laws, for use in accordance with the U.S. and Canadian plumbing codes. U.S. Patent 7,246,635 B2.

**DYNAMIC BALANCING VALVES FOR PLUMBING AND HYDRONICS**



**127 FlowCal™ sweat**

Compact automatic recirculation balancing valves.  
 DZR low-lead brass bodies.  
 Patented anti-scale, low noise polymer.  
 Max. working pressure: 230 psi.  
 Temperature range: 32°—212°F.  
 Max. percentage of glycol: 50%  
 Flow rate range: 0.35 to 10 GPM.  
 Flow accuracy: ±10%.  
 Select desired flow rate on **page 76** to complete full part number.

Code	Description	Lbs	USD
<b>127349AF ***</b>	½" sweat union	0.8	<b>108.00</b>
<b>127359AF ***</b>	¾" sweat union	0.8	<b>114.00</b>
<b>127369AF ***</b>	1" sweat union	1.0	<b>131.00</b>



**127 FlowCal™ NPT**

Compact automatic recirculation balancing valves.  
 DZR low-lead brass bodies.  
 Patented anti-scale, low noise polymer.  
 Max. working pressure: 230 psi.  
 Temperature range: 32°—212°F.  
 Max. percentage of glycol: 50%  
 Flow rate range: 0.35 to 10 GPM.  
 Flow accuracy: ±10%.  
 Select desired flow rate on **page 76** to complete full part number..

Code	Description	Lbs	USD
<b>127341AF ***</b>	½" NPT male union	1.0	<b>115.00</b>
<b>127351AF ***</b>	¾" NPT male union	1.0	<b>119.00</b>
<b>127361AF ***</b>	1" NPT male union	1.2	<b>135.00</b>



**127 FlowCal™ press**

Compact automatic recirculation balancing valves.  
 DZR low-lead brass bodies.  
 Patented anti-scale, low noise polymer.  
 Max. working pressure: 230 psi.  
 Temperature range: 32°—212°F.  
 Max. percentage of glycol: 50%  
 Flow rate range: 0.35 to 10 GPM.  
 Flow accuracy: ±10%.  
 Select desired flow rate on **page 76** to complete full part number.

Code	Description	Lbs	USD
<b>127346AF ***</b>	½" press union	0.9	<b>127.00</b>
<b>127356AF ***</b>	¾" press union	1.0	<b>140.00</b>
<b>127366AF ***</b>	1" press union	1.3	<b>171.00</b>



**127 FlowCal™ PEX**

Compact automatic recirculation balancing valves.  
 DZR low-lead brass bodies.  
 Patented anti-scale, low noise polymer.  
 Max. working pressure: 230 psi.  
 Temperature range: 32°—212°F.  
 Max. percentage of glycol: 50%  
 Flow rate range: 0.35 to 10 GPM.  
 Flow accuracy: ±10%.  
 PEX crimp: ASTM F1807  
 PEX expansion: ASTM F1960  
 Select desired flow rate on **page 76** to complete full part number.

Code	Description	Lbs	USD
<b>127344AF ***</b>	½" PEX crimp union	1.0	<b>108.00</b>
<b>127342AF ***</b>	½" PEX expansion union	1.0	<b>108.00</b>
<b>127354AF ***</b>	¾" PEX crimp union	1.0	<b>114.00</b>
<b>127352AF ***</b>	¾" PEX expansion union	1.0	<b>114.00</b>
<b>127364AF ***</b>	1" PEX crimp union	1.3	<b>131.00</b>
<b>127362AF ***</b>	1" PEX expansion union	1.3	<b>131.00</b>



**127 FlowCal™ body**

Compact automatic recirculation balancing valves.  
 DZR low-lead brass bodies.  
 Patented anti-scale, low noise polymer.  
 Max. working pressure: 230 psi.  
 Temperature range: 32°—212°F.  
 Max. percentage of glycol: 50%  
 Flow rate range: 0.35 to 10 GPM.  
 Flow accuracy: ±10%.  
 Select desired flow rate on **page 76** to complete full part number.

Code	Description	Lbs	USD
<b>127000A ***</b>	127 body + *** GPM cartridge, no fittings	1.0	<b>82.20</b>



Union isolation ball valve  
 Low lead MxF union fits between valve body and tailpiece.

Code	Description	Lbs	USD
<b>290030</b>	1" M x 1" F union ball valve	1.0	<b>47.60</b>
<b>NA10815</b>	Stem extension for 290030	0.2	<b>27.10</b>

Complies with NSF/ANSI/CAN 372, low lead laws, for use in accordance with the U.S. and Canadian plumbing codes. U.S. Patent 7,246,635 B2.

**DYNAMIC BALANCING VALVES FOR PLUMBING AND HYDRONICS**



**127 FlowCal+™ sweat**

Compact automatic recirculation balancing valves. Patented anti-scale, low noise polymer. FlowCal™ cartridge. Inlet flow check valve. Max. working pressure: 230 psi. Temperature range: 32°–212°F. Max. percentage of glycol: 50% Flow rate range: 0.35 to 10 GPM. Flow accuracy: ±10%. Dual scale: 30 – 210°F (0° – 100°C). Gauge accuracy: ± 6°F. Select desired flow rate on **page 76** to complete full part number.

Code	Description	Lbs	USD
<b>127148AFC ***</b>	<b>½" sweat union</b>	<b>1.0</b>	<b>156.00</b>
<b>127158AFC ***</b>	<b>¾" sweat union</b>	<b>1.0</b>	<b>170.00</b>
<b>127168AFC ***</b>	<b>1" sweat union</b>	<b>1.2</b>	<b>198.00</b>



**127 FlowCal+™ NPT**

Compact automatic recirculation balancing valves. Patented anti-scale, low noise polymer. FlowCal™ cartridge. Inlet flow check valve. Max. working pressure: 230 psi. Temperature range: 32°–212°F. Max. percentage of glycol: 50% Flow rate range: 0.35 to 10 GPM. Flow accuracy: ±10%. Dual scale: 30 – 210°F (0° – 100°C). Gauge accuracy: ± 6°F. Select desired flow rate on **page 76** to complete full part number.

Code	Description	Lbs	USD
<b>127140AFC ***</b>	<b>½" NPT male union</b>	<b>1.2</b>	<b>161.00</b>
<b>127150AFC ***</b>	<b>¾" NPT male union</b>	<b>1.2</b>	<b>193.00</b>
<b>127160AFC ***</b>	<b>1" NPT male union</b>	<b>1.4</b>	<b>200.00</b>



**127 FlowCal+™ press**

Compact automatic recirculation balancing valves. Patented anti-scale, low noise polymer. FlowCal™ cartridge. Inlet flow check valve. Max. working pressure: 230 psi. Temperature range: 32°–212°F. Max. percentage of glycol: 50% Flow rate range: 0.35 to 10 GPM. Flow accuracy: ±10%. Dual scale: 30 – 210°F (0° – 100°C). Gauge accuracy: ± 6°F. Select desired flow rate on **page 76** to complete full part number.

Code	Description	Lbs	USD
<b>127147AFC ***</b>	<b>½" press union</b>	<b>1.0</b>	<b>151.00</b>
<b>127157AFC ***</b>	<b>¾" press union</b>	<b>1.2</b>	<b>188.00</b>
<b>127167AFC ***</b>	<b>1" press union</b>	<b>1.5</b>	<b>207.00</b>



**127 FlowCal+™ PEX**

Compact automatic recirculation balancing valves. Patented anti-scale, low noise polymer. FlowCal™ cartridge. Inlet flow check valve. Max. working pressure: 230 psi. Temperature range: 32°–212°F. Max. percentage of glycol: 50% Flow rate range: 0.35 to 10 GPM. Flow accuracy: ±10%. Dual scale: 30 – 210°F (0° – 100°C). Gauge accuracy: ± 6°F. PEX crimp: ASTM F1807 PEX expansion: ASTM F1960 Select desired flow rate on **page 76** to complete full part number.

Code	Description	Lbs	USD
<b>127145AFC ***</b>	<b>½" PEX crimp union</b>	<b>1.2</b>	<b>156.00</b>
<b>127143AFC ***</b>	<b>½" PEX expansion union</b>	<b>1.2</b>	<b>156.00</b>
<b>127155AFC ***</b>	<b>¾" PEX crimp union</b>	<b>1.2</b>	<b>170.00</b>
<b>127153AFC ***</b>	<b>¾" PEX expansion union</b>	<b>1.2</b>	<b>170.00</b>
<b>127165AFC ***</b>	<b>1" PEX crimp union</b>	<b>1.5</b>	<b>198.00</b>
<b>127163AFC ***</b>	<b>1" PEX expansion union</b>	<b>1.5</b>	<b>198.00</b>

**Flow rate selection for 127 and 128 FlowCal™**

GPM	Last 3 digits ...	Differential Pressure Control Ranges (psid)
0.35	G35	2–14
.5	G50	
.75	G75	
1.0	1G0	2–32
1.3	1G3	
1.5	1G5	
1.7	1G7	
2.0	2G0	
2.2	2G2	
2.5	2G5	
2.6	2G6	
3.0	3G0	
3.5	3G5	
4.0	4G0	4–34
4.5	4G5	
5.0	5G0	
6.0	6G0	
7.0	7G0	5–35
8.0	8G0	
9.0	9G0	
10	10G	

Complies with NSF/ANSI/CAN 372, low lead laws, for use in accordance with the U.S. and Canadian plumbing codes. US Patent 7,246,635 B2.

**DYNAMIC BALANCING VALVES FOR PLUMBING AND HYDRONICS**



**127 FlowCal+™ sweat**

Compact automatic recirculation balancing valves. Patented anti-scale, low noise polymer. DZR low-lead brass bodies. FlowCal™ cartridge. Inlet flow check valve. Max. working pressure: 230 psi. Temperature range: 32°—212°F. Max. percentage of glycol: 50%. Flow rate range: 0.35 to 10 GPM. Flow accuracy: ±10%. Select desired flow rate on **page 76** to complete full part number.

Code	Description	Lbs	USD
127149AFC ***	1/2" sweat union	0.8	<b>119.00</b>
127159AFC ***	3/4" sweat union	0.8	<b>129.00</b>
127169AFC ***	1" sweat union	1.0	<b>159.00</b>



**127 FlowCal+™ NPT**

Compact automatic recirculation balancing valves. Patented anti-scale, low noise polymer. DZR low-lead brass bodies. FlowCal™ cartridge. Inlet flow check valve. Max. working pressure: 230 psi. Temperature range: 32°—212°F. Max. percentage of glycol: 50%. Flow rate range: 0.35 to 10 GPM. Flow accuracy: ±10%. Select desired flow rate on **page 76** to complete full part number.

Code	Description	Lbs	USD
127141AFC ***	1/2" NPT male union	1.0	<b>120.00</b>
127151AFC ***	3/4" NPT male union	1.0	<b>128.00</b>
127161AFC ***	1" NPT male union	1.2	<b>161.00</b>



**127 FlowCal+™ press**

Compact automatic recirculation balancing valves. Patented anti-scale, low noise polymer. DZR low-lead brass bodies. FlowCal™ cartridge. Inlet flow check valve. Max. working pressure: 230 psi. Temperature range: 32°—212°F. Max. percentage of glycol: 50%. Flow rate range: 0.35 to 10 GPM. Flow accuracy: ±10%. Select desired flow rate on **page 76** to complete full part number.

Code	Description	Lbs	USD
127146AFC ***	1/2" press union	0.9	<b>119.00</b>
127156AFC ***	3/4" press union	1.0	<b>147.00</b>
127166AFC ***	1" press union	1.3	<b>169.00</b>



**127 FlowCal+™ PEX**

Compact automatic recirculation balancing valves. Patented anti-scale, low noise polymer. DZR low-lead brass bodies. FlowCal™ cartridge. Inlet flow check valve. Max. working pressure: 230 psi. Temperature range: 32°—212°F. Max. percentage of glycol: 50%. Flow rate range: 0.35 to 10 GPM. Flow accuracy: ±10%. PEX crimp: ASTM F1807. PEX expansion: ASTM F1960. Select desired flow rate on **page 76** to complete full part number.

Code	Description	Lbs	USD
127144AFC ***	1/2" PEX crimp union	1.0	<b>119.00</b>
127142AFC ***	1/2" PEX expansion union	1.0	<b>129.00</b>
127154AFC ***	3/4" PEX crimp union	1.0	<b>159.00</b>
127152AFC ***	3/4" PEX expansion union	1.0	<b>119.00</b>
127164AFC ***	1" PEX crimp union	1.3	<b>129.00</b>
127162AFC ***	1" PEX expansion union	1.3	<b>159.00</b>

**Construction details FlowCal+**

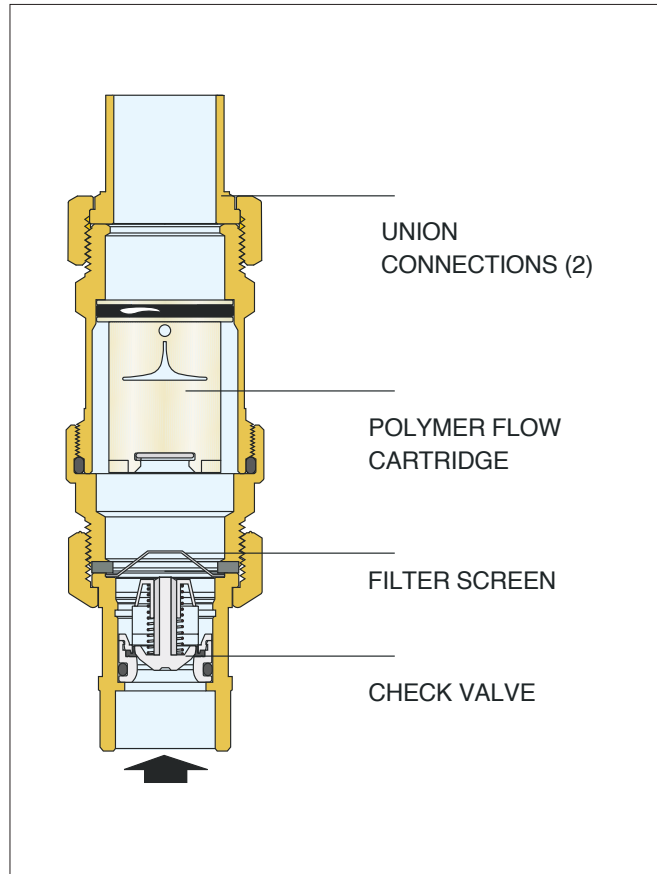

Complies with NSF/ANSI/CAN 372, low lead laws, for use in accordance with the U.S. and Canadian plumbing codes. US Patent 7,246,635 B2.

**DYNAMIC BALANCING VALVES FOR HYDRONICS**

**121  
FlowCal™**

Automatic flow balancing valve with integral ball valve.  
 Not for use in potable water / plumbing systems, not low lead  
 Brass body.  
 Patented anti-scale, low noise polymer FlowCal™ cartridge.  
 Maximum working pressure: 400 psi (400 WOG).  
 Working temperature range: 32°–212°F ( 0°–100°C).  
 Max. percentage of glycol: 50%.  
 Differential pressure control ranges: 2–14, 2–32, 4–34, 5–35 psid.  
 Flow rate: fixed flow rate settings ranging from 0.35–21 GPM.  
 Flow accuracy: ±10%.  
 US Patent 7,246,635 B2.

Available with optional factory-installed pressure and temperature test ports  
 (1213xxx Series).

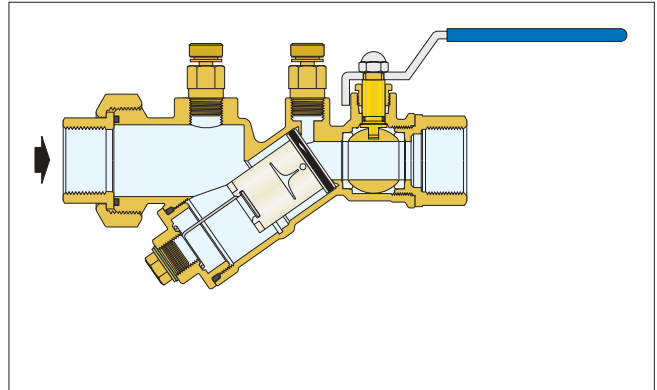

Select desired flow rate to complete full part number.

Size	GPM	Last 3 digits ...	Differential Pressure Control Ranges (psid)
1/2", 3/4"	0.35	G35	2 – 14
1/2", 3/4"	0.5	G50	
1/2", 3/4"	0.75	G75	
1/2", 3/4"	1	1G0	2 – 32
1/2", 3/4"	1.3	1G3	
1/2", 3/4"	1.5	1G5	
1/2", 3/4"	1.7	1G7	
1/2", 3/4"	2	2G0	
1/2", 3/4"	2.2	2G2	
1/2", 3/4"	2.5	2G5	
1/2", 3/4", 1"	2.6	2G6	
1/2", 3/4", 1"	3	3G0	
1/2", 3/4", 1"	3.5	3G5	
1/2", 3/4", 1", 1 1/4"	4	4G0	4 – 34
1/2", 3/4", 1", 1 1/4"	4.5	4G5	
1/2", 3/4", 1", 1 1/4"	5	5G0	
1/2", 3/4", 1", 1 1/4"	6	6G0	
1/2", 3/4", 1", 1 1/4"	7	7G0	
1/2", 3/4", 1", 1 1/4"	8	8G0	

Code	Description	Lbs	USD
121141A ...	1/2" NPT female	2.7	142.00
121149A ...	1/2" sweat	2.7	136.00
121151A ...	3/4" NPT female	2.7	143.00
121159A ...	3/4" sweat	2.7	137.00
121161A ...	1" NPT female	5.0	294.00
121169A ...	1" sweat	5.0	280.00
121171A ...	1 1/4" NPT female	5.0	330.00
121179A ...	1 1/4" sweat	5.0	314.00
121341A ...	1/2" NPT female with PT test ports	3.2	153.00
121349A ...	1/2" sweat with PT test ports	3.2	145.00
121351A ...	3/4" NPT female with PT test ports	3.2	157.00
121359A ...	3/4" sweat with PT test ports	3.2	146.00
121361A ...	1" NPT female with PT test ports	5.5	304.00
121369A ...	1" sweat with PT test ports	5.5	290.00
121371A ...	1 1/4" NPT female with PT test ports	5.5	340.00
121379A ...	1 1/4" sweat with PT test ports	5.5	323.00

Size	GPM	Last 3 digits ...	Differential Pressure Control Ranges (psid)
1/2", 3/4", 1", 1 1/4"	9	9G0	5 – 35
1/2", 3/4", 1", 1 1/4"	10	10G	
1", 1 1/4"	11	11G	3 – 32
1", 1 1/4"	12	12G	
1", 1 1/4"	13	13G	
1", 1 1/4"	14	14G	4 – 35
1", 1 1/4"	15	15G	
1", 1 1/4"	16	16G	
1", 1 1/4"	17	17G	
1", 1 1/4"	18	18G	
1", 1 1/4"	19	19G	
1", 1 1/4"	20	20G	
1", 1 1/4"	21	21G	

Size	Flow Rates
1/2"	.35 – 10 GPM
3/4"	.35 – 10 GPM
1"	2.5 – 21 GPM
1 1/4"	4 – 21 GPM

Replacement flow cartridge kits are available. Consult factory.

**THERMAL BALANCING VALVES FOR PLUMBING**



**1164 ThermoSetter™**

Compact adjustable thermal balancing valve for domestic hot water recirculation circuits. Drywell for optional temperature gauge or probe. DZR low-lead brass body. Optional outlet check valve. Max. working pressure: 230 psi. Adjustment temperature range: 105° — 150°F. Cv max: 2.1; Cv min: 0.35. Cv design: 0.69.



**1163 ThermoSetter™**

Adjustable thermal balancing valve for domestic hot water recirculation circuits. With by-pass valve for thermal disinfection. Purchase 656 actuator separately. Temperature gauge included. DZR low-lead brass body. Optional outlet check valve. Max. working pressure: 230 psi. 1/2" and 3/4" models: Adjustment range; 95° — 140°F. Cv max: 2.1; Cv min: 0.23. Cv disinfection: 1.2; Cv design: 0.52. 1" and 1 1/4" models: Adjustment range: 95° — 150°F. Cv max: 4.4; Cv min: 1.0. Cv disinfection: 2.3; Cv design: 1.9.

Code	Description	Lbs	USD
<b>116440A</b>	1/2" FNPT	1.6	<b>203.00</b>
<b>116440AC</b>	1/2" FNPT, check valve	1.8	<b>247.00</b>
<b>116441A</b>	1/2" FNPT, gauge	1.5	<b>216.00</b>
<b>116441AC</b>	1/2" FNPT, gauge, check valve	1.7	<b>263.00</b>
<b>116450A</b>	3/4" FNPT	1.6	<b>218.00</b>
<b>116450AC</b>	3/4" FNPT, check valve	1.8	<b>271.00</b>
<b>116451A</b>	3/4" FNPT, gauge	1.5	<b>233.00</b>
<b>116451AC</b>	3/4" FNPT, gauge, check valve	1.7	<b>284.00</b>

Code	Description	Lbs	USD
<b>116340A</b>	1/2" FNPT	1.8	<b>307.00</b>
<b>116340AC</b>	1/2" FNPT, check valve	2.0	<b>353.00</b>
<b>116350A</b>	3/4" FNPT	1.7	<b>323.00</b>
<b>116350AC</b>	3/4" FNPT, check valve	1.9	<b>376.00</b>
<b>116360A</b>	1" FNPT, gauge	2.3	<b>426.00</b>
<b>116360AC</b>	1" FNPT, gauge, check valve	2.5	<b>559.00</b>
<b>116370A</b>	1 1/4" FNPT, gauge	2.2	<b>451.00</b>
<b>116370AC</b>	1 1/4" FNPT, gauge, check valve	2.4	<b>597.00</b>

**Construction details**

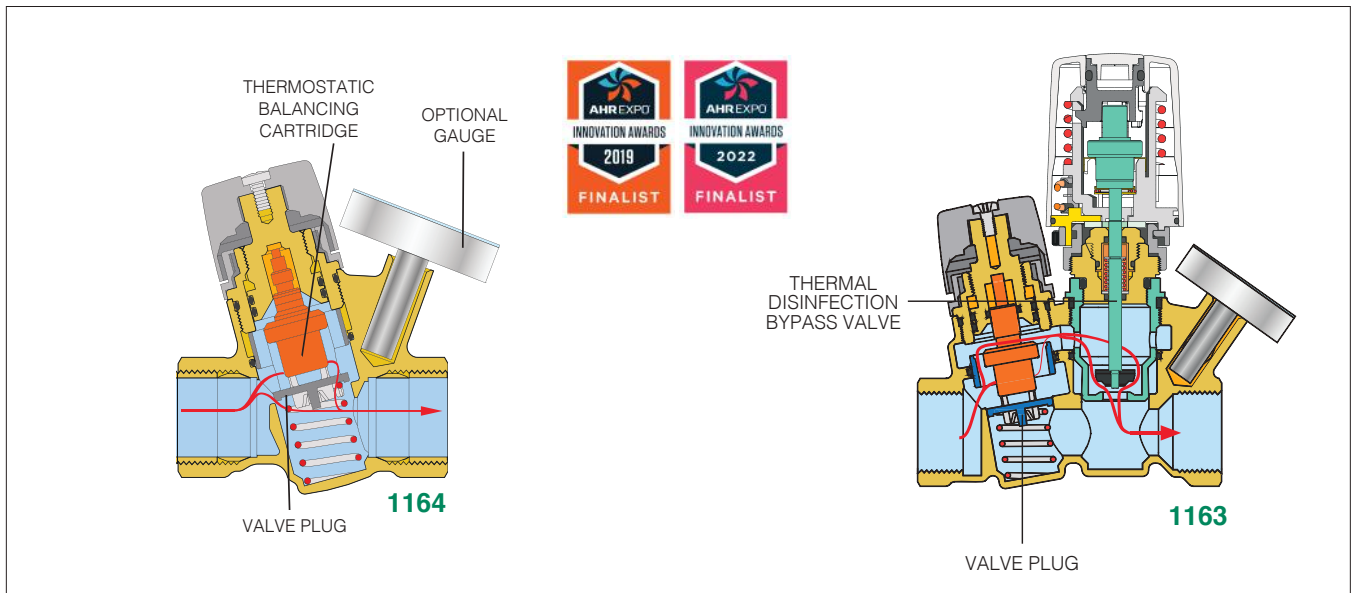

Complies with NSF/ANSI/CAN 372 low lead laws for use in accordance with the U.S. and Canadian plumbing codes, and with NSF/ANSI/CAN 61 (180F).

**THERMAL BALANCING VALVES FOR PLUMBING**



**1162, 1166  
ThermoSetter™**

Adjustable thermal balancing valve for domestic hot water recirculation circuits. With thermal by-pass cartridge for thermal disinfection.  
DZR low-lead brass body.  
Temperature gauge included.  
Max. working pressure: 230 psi.  
½" and ¾" models:  
Adjustment range; 95° – 140°F  
Cv max: 2.1; Cv min: 0.23.  
Cv disinfection: 1.2; Cv design: 0.52.  
1" and 1¼" models:  
Adjustment range; 95° – 150°F  
Cv max: 4.4; Cv min: 1.0.  
Cv disinfection: 2.3; Cv design: 1.9.



**1161  
ThermoSetter™**

Adjustable thermal balancing valve for domestic hot water recirculation circuits. Drywell for optional temperature gauge or probe.  
DZR low-lead brass body.  
Max. working pressure: 230 psi.  
½" and ¾" models:  
Adjustment range; 95° – 140°F  
Cv max: 2.1; Cv min: 0.23.  
Cv disinfection: 1.2; Cv design: 0.52.  
1" and 1¼" models:  
Adjustment range; 95° – 150°F  
Cv max: 4.4; Cv min: 1.0.  
Cv disinfection: 2.3; Cv design: 1.9.

Code	Description	Lbs	USD
116240A	½" FNPT, 160°F bypass	1.8	294.00
116240AC	½" FNPT, check valve, 160°F bypass	2.0	336.00
116250A	¾" FNPT, 160°F bypass	1.7	308.00
116250AC	¾" FNPT, check valve, 160°F bypass	1.9	361.00
116260A	1" FNPT, 160°F bypass	1.8	411.00
116260AC	1" FNPT check, 160°F bypass	2.0	543.00
116270A	1-¼" FNPT, 160°F bypass	1.7	438.00
116270AC	1¼" FNPT, check, 160°F bypass	1.9	583.00
116640A	½" FNPT, 140°F bypass	1.8	294.00
116640AC	½" FNPT, check valve, 140°F bypass	2.0	336.00
116650A	¾" FNPT, 140°F bypass	1.7	308.00
116650AC	¾" FNPT, check valve, 140°F bypass	1.9	361.00
116660A	1" FNPT, 140°F bypass	2.3	411.00
116660AC	1" FNPT, check, 140°F bypass	2.5	543.00
116670A	1¼" FNPT, 140°F bypass	2.2	438.00
116670AC	1¼" FNPT, check, 140°F bypass	2.4	583.00

Code	Description	Lbs	USD
116140A	½" FNPT	1.6	244.00
116140AC	½" FNPT, check valve	1.8	298.00
116141A	½" FNPT, gauge	1.7	260.00
116141AC	½" FNPT, gauge, check valve	1.9	316.00
116150A	¾" FNPT	1.5	262.00
116150AC	¾" FNPT, check valve	1.7	324.00
116151A	¾" FNPT, gauge	1.6	279.00
116151AC	¾" FNPT, gauge, check valve	1.8	342.00
116160A	1" FNPT	2.1	343.00
116160AC	1" FNPT, check	2.3	476.00
116161A	1" FNPT, gauge	2.2	358.00
116161AC	1" FNPT, gauge, check	2.4	492.00
116170A	1¼" FNPT	2.0	369.00
116170AC	1¼" FNPT, check	2.2	515.00
116171A	1¼" FNPT, gauge	2.1	383.00
116171AC	1¼" FNPT, gauge, check	2.3	530.00

**Construction details**

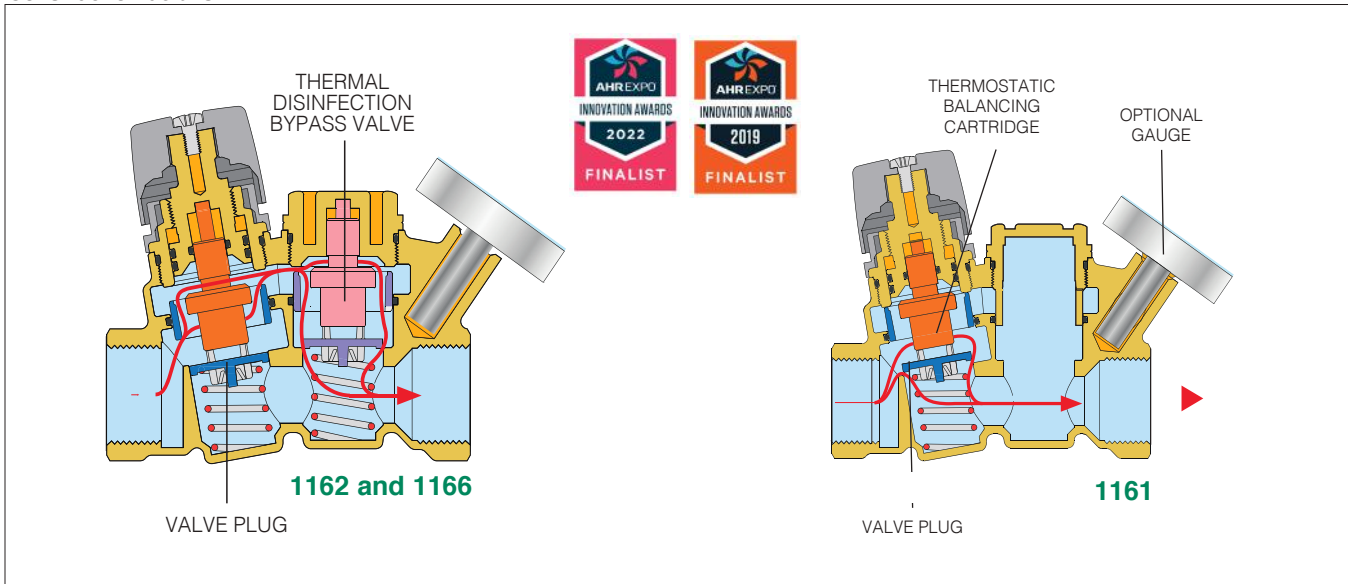

Complies with NSF/ANSI/CAN 372 low lead laws for use in accordance with the U.S. and Canadian plumbing codes, and with NSF/ANSI/CAN 61 (180F).



**THERMAL BALANCING VALVES FOR PLUMBING**



Thermal disinfection bypass cartridges.

Code	Description	Lbs	USD
<b>F0001286</b>	140°F bypass cartridge	0.1	<b>52.70</b>
<b>F0000580</b>	160°F bypass cartridge	0.1	<b>52.70</b>



Replacement main balancing cartridge.

Code	Description	Lbs	USD
<b>F0001516</b>	½", ¾" balancing cartridge	0.1	<b>52.70</b>



Temperature gauge fits 116 ThermoSetter™. Working temperature range: 30° – 180°F.

Code	Description	Lbs	USD
<b>116010</b>	1½" dial temp. gauge	0.1	<b>15.00</b>



Insulation shell fits 116 ThermoSetter™ thermal balancing valve.

Code	Description	Lbs	USD
<b>CBN116140*</b>	Insulation shell for 1161, 1162, 1163	0.1	<b>36.40</b>
<b>CBN116440*</b>	Insulation shell for 1164	0.1	<b>35.70</b>
<b>CBN116160**</b>	Insulation shell for 1161, 1162, 1163	0.1	<b>38.90</b>

\*Fits ½" and ¾"  
\*\*Fits 1" and 1¼"



Actuator disinfection cartridge for use with 656 actuator.

Code	Description	Lbs	USD
<b>116000</b>	Replacement actuator bypass cartridge	0.1	<b>68.00</b>



Check valve fits 116 ThermoSetter™. DZR low-lead brass. Max. working pressure: 150 psi. Max. working temperature: 250°F.

Code	Description	Lbs	USD
<b>NA10469</b>	½" FNPT x MNPT inline check valve	0.1	<b>45.30</b>
<b>NA10467</b>	¾" FNPT x MNPT inline check valve	0.1	<b>52.70</b>
<b>NA51361*</b>	1" MNPT in, 1" FNPT out	1.1	<b>131.00</b>
<b>NA51371*</b>	1¼" MNPT in, 1¼" FNPT out	1.3	<b>144.00</b>



Low lead brass pipe nipples. For connecting NA108 ball valve to other FNPT valves such as 130, 132, 142, 116 Series.

Code	Description	Lbs	USD
<b>NA10834</b>	½" NPT nipple	0.1	<b>4.80</b>
<b>NA10835</b>	¾" NPT nipple	0.1	<b>7.60</b>
<b>NA10836</b>	1" NPT nipple	0.1	<b>11.90</b>
<b>NA10837</b>	1¼" NPT nipple	0.3	<b>20.60</b>
<b>NA10838</b>	1½" NPT nipple	0.3	<b>21.60</b>
<b>NA10839</b>	2" NPT nipple	0.5	<b>31.40</b>



**NA108**

NPT full port ball valves with extended operator handle for insulated or bare pipes. For use with hot or cold water piping in plumbing or hydronic applications. High strength forged low lead brass. Blowout-proof stem with dual o-ring seals. Pressure rating 600 WOG. Temperature rating -4° – 366°F.

Code	Description	Lbs	USD
<b>NA10824</b>	½" FNPT ball valve low lead	0.4	<b>38.40</b>
<b>NA10825</b>	¾" FNPT ball valve low lead	0.6	<b>47.10</b>
<b>NA10826</b>	1" FNPT ball valve low lead	1.0	<b>61.10</b>
<b>NA10827</b>	1¼" FNPT ball valve low lead	1.6	<b>102.00</b>
<b>NA10828</b>	1½" FNPT ball valve low lead	1.9	<b>129.00</b>
<b>NA10829</b>	2" FNPT ball valve low lead	3.0	<b>314.00</b>

To order a ThermoSetter™ with isolation ball valves, add suffix "...001" to any of the 116 Series code numbers listed in these pages. See NA108 Series on page 93 for isolation valve details. **Contact Caleffi for 116...001 List Prices.**



# PRESCAL™ PRVS

## PRECISION ENGINEERED FOR DURABLE PERFORMANCE



The **PresCal™** pressure reducing valve family is constructed of dezincification-resistant low lead brass and low friction moving parts that stand up to hard water and scale for maximum durability. The diaphragm models as well as the new **true piston** models feature a service-friendly **removable cartridge** with integral stainless steel mesh strainer that makes cleaning or rebuilding **fast and easy**. **Approvals include compliance with U.S. and Canadian plumbing codes. CALEFFI GUARANTEED.**



# PRVS, BACKFLOW PREVENTERS AND VACUUM RELIEF VALVES

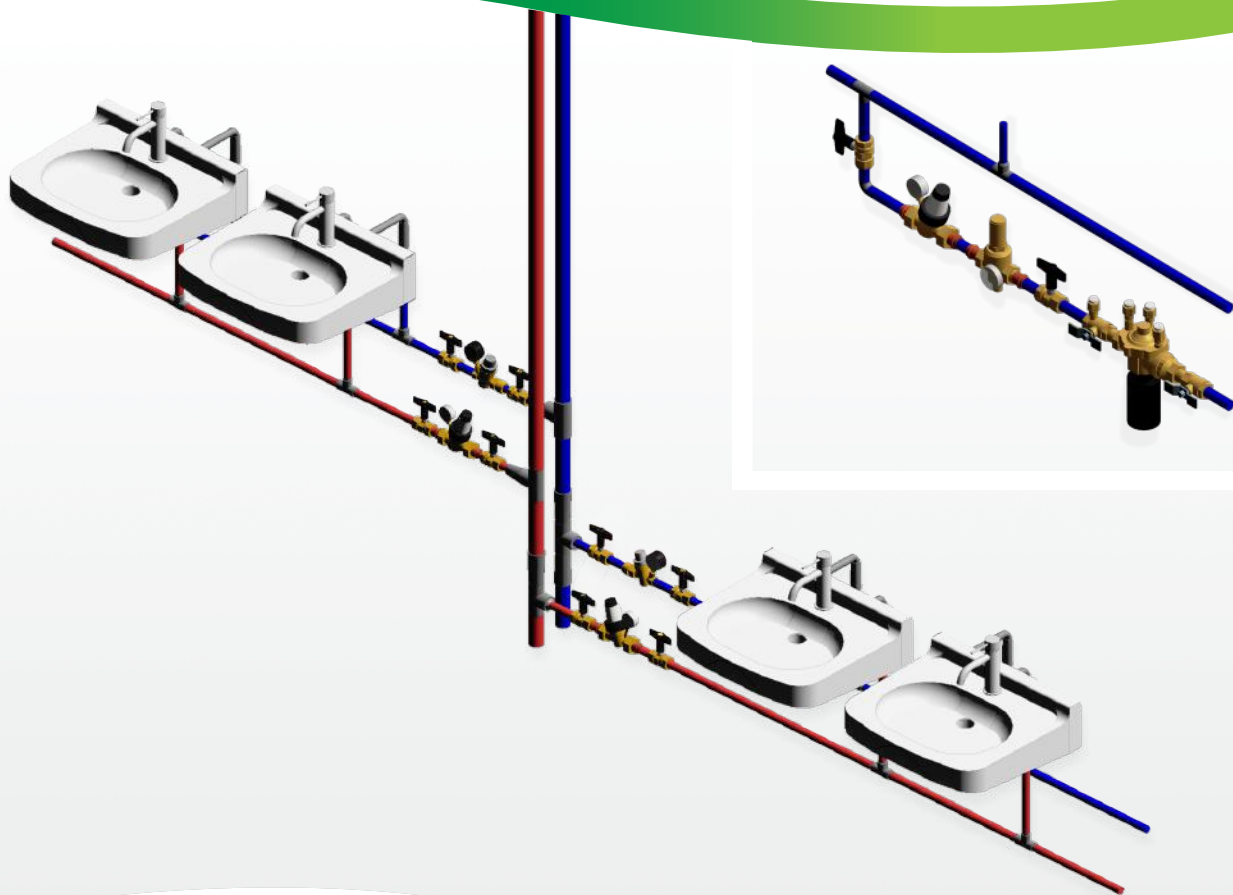

This diagram is for illustration purposes only



**BIM**  
bim.caleffi.com

## PRODUCTS INCLUDED IN SECTION

- Pressure reducing valves
- Backflow preventers, RPZ type
- Backflow preventers, dual check
- Vacuum relief valve

**PRESSURE REDUCING VALVES**



**535H PresCal™ sweat**

Pressure reducing valve for residential and commercial applications. DZR low-lead brass body. Max. working pressure: 300 psi. Max. working temperature: 180°F. Pressure setting range: 15 — 90 psi. Front and back set point indication for visibility in any mounting orientation. UV protective cover included.



**535H PresCal™ NPT**

Pressure reducing valve for residential and commercial applications. DZR low-lead brass body. Max. working pressure: 300 psi. Max. working temperature: 180°F. Pressure setting range: 15 — 90 psi. Front and back set point indication for visibility in any mounting orientation. UV protective cover included.

Code	Description	Max GPM	Lbs	USD
535940HA	½" sweat union	7.3	1.9	<b>117.00</b>
535941HA*	½" sweat union	7.3	2.0	<b>128.00</b>
535950HA	¾" sweat union	12	2.2	<b>128.00</b>
535951HA*	¾" sweat union	12	2.3	<b>140.00</b>
535960HA	1" sweat union	19	2.9	<b>168.00</b>
535961HA*	1" sweat union	19	3.0	<b>180.00</b>
535970HA	1¼" sweat union	34	5.6	<b>372.00</b>
535971HA*	1¼" sweat union	34	5.7	<b>383.00</b>
535980HA	1½" sweat union	44	7.3	<b>522.00</b>
535981HA*	1½" sweat union	44	7.4	<b>533.00</b>
535990HA	2" sweat union	70	9.7	<b>677.00</b>
535991HA*	2" sweat union	70	9.8	<b>689.00</b>

GPM flowrate at 6 feet per second water velocity.  
\*With gauge

Code	Description	Max GPM	Lbs	USD
535340HA	½" NPT female union	7.3	2.0	<b>128.00</b>
535341HA*	½" NPT female union	7.3	2.1	<b>140.00</b>
535350HA	¾" NPT female union	12	2.3	<b>137.00</b>
535351HA*	¾" NPT female union	12	2.4	<b>148.00</b>
535360HA	1" NPT female union	19	3.0	<b>179.00</b>
535361HA*	1" NPT female union	19	3.1	<b>190.00</b>
535370HA	1¼" NPT female union	34	5.7	<b>383.00</b>
535371HA*	1¼" NPT female union	34	5.8	<b>395.00</b>
535380HA	1½" NPT female union	44	7.3	<b>549.00</b>
535381HA*	1½" NPT female union	44	7.4	<b>560.00</b>
535390HA	2" NPT female union	70	9.7	<b>677.00</b>
535391HA*	2" NPT female union	70	9.8	<b>689.00</b>

GPM flowrate at 6 feet per second water velocity.  
\*With gauge

**Construction details 535H PresCal™**

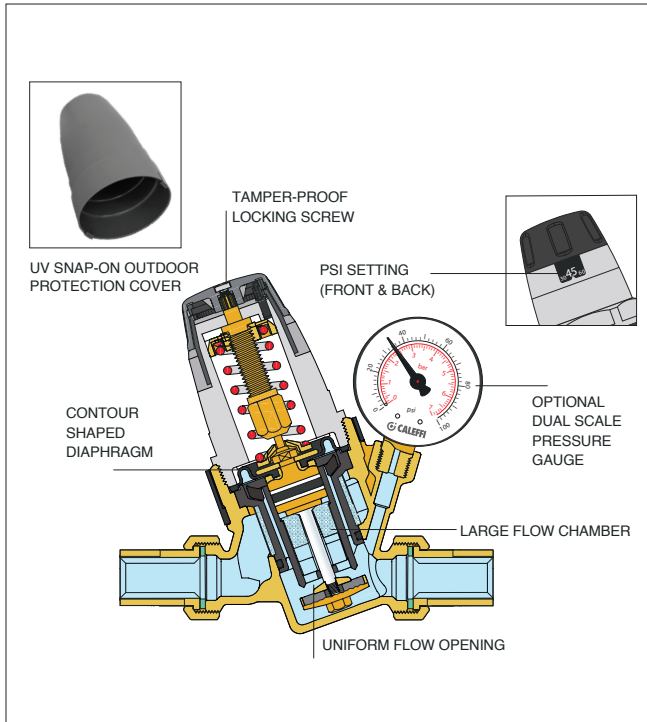

**535H PresCal™ press**



Pressure reducing valve for residential and commercial applications. DZR low-lead brass body. Max. working pressure: 300 psi. Max. working temperature: 180°F. Pressure setting range: 15 — 90 psi. Front and back set point indication for visibility in any mounting orientation. UV protective cover included.

Code	Description	Max GPM	Lbs	USD
535640HA	½" press union	<b>NEW</b> 7.3	1.9	<b>207.00</b>
535641HA*	½" press union	<b>NEW</b> 7.3	2.0	<b>225.00</b>
535650HA	¾" press union	12	2.3	<b>144.00</b>
535651HA*	¾" press union	12	2.4	<b>155.00</b>
535660HA	1" press union	19	3.0	<b>195.00</b>
535661HA*	1" press union	19	3.1	<b>207.00</b>
535670HA	1¼" press union	34	5.8	<b>543.00</b>
535671HA*	1¼" press union	34	5.8	<b>554.00</b>
535680HA	1½" press union	44	7.3	<b>779.00</b>
535681HA*	1½" press union	44	7.4	<b>791.00</b>
535690HA	2" press union	70	9.7	<b>960.00</b>
535691HA*	2" press union	70	9.8	<b>971.00</b>

GPM flowrate at 6 feet per second water velocity.  
\*With gauge

Complies with: ASSE 1003, CSA B356, NSF/ANSI/CAN 61, NSF/ANSI/CAN 372, Low Lead Laws and listed by ICC-ES. Meets codes IPC, IRC & UPC for use in accordance with the U.S. and Canadian plumbing codes. Plenum rated: compliant with the requirements of standard UL 2043.

**PRESSURE REDUCING VALVES**



**535H PresCal™ PEX**

Pressure reducing valve for residential and commercial applications.  
 DZR low-lead brass body.  
 Max. working pressure: 300 psi.  
 Max. working temperature: 180°F.  
 Pressure setting range: 15 — 90 psi.  
 PEX crimp: ASTM F1807.  
 PEX expansion: ASTM F1960.  
 Front and back set point indication for visibility in any mounting orientation.  
 UV protective cover included.

Code	Description	Max GPM	Lbs	USD
535750HA	¾" PEX crimp union	12	2.3	<b>128.00</b>
535751HA*	¾" PEX crimp union	12	2.4	<b>140.00</b>
535550HA	¾" PEX expansion union	19	2.3	<b>168.00</b>
535551HA*	¾" PEX expansion union	19	2.4	<b>180.00</b>
535760HA	1" PEX crimp union	12	3.0	<b>128.00</b>
535761HA*	1" PEX crimp union	12	3.1	<b>140.00</b>
535560HA	1" PEX expansion union	19	3.0	<b>168.00</b>
535561HA*	1" PEX expansion union	19	3.1	<b>180.00</b>

GPM flowrate at 6 feet per second water velocity.  
 \*With gauge



PVC jumper nipple with male union thread. The length of the jumper nipple matches the 535H Series valve body face-to-face dimension (B'), allowing the piping to be completed prior to the installation of valve and permitting quick change out from the jumper to the valve.

Code	Description	Lbs	USD
<b>NA11304</b>	Jumper nipple for 535H ½"	0.1	<b>15.90</b>
<b>NA11305</b>	Jumper nipple for 535H ¾"	0.1	<b>17.50</b>
<b>NA11306</b>	Jumper nipple for 535H 1"	0.2	<b>18.70</b>
<b>NA11307</b>	Jumper nipple for 535H 1¼"	0.3	<b>20.10</b>
<b>NA11308</b>	Jumper nipple for 535H 1½"	0.3	<b>21.90</b>
<b>NA11309</b>	Jumper nipple for 535H 2"	0.5	<b>63.20</b>

Complies with: ASSE 1003, CSA B356, NSF/ANSI/CAN 61, NSF/ANSI/CAN 372, Low Lead Laws and listed by ICC-ES. Meets codes IPC, IRC & UPC for use in accordance with the U.S. and Canadian plumbing codes. Plenum rated: compliant with the requirements of standard UL 2043.



**535H PresCal™ Body**

Replacement valve body.  
 DZR low lead body.  
 Gauge port plug NA10438 included with body.  
 See fitting selection table in Section 8.

Code	Description	Lbs	USD
<b>NA535840HA</b>	½" body	1.9	<b>89.10</b>
<b>NA535841HA</b>	½" body, gauge	2.0	<b>100.80</b>
<b>NA535850HA</b>	¾" body	2.2	<b>93.90</b>
<b>NA535851HA</b>	¾" body, gauge	2.3	<b>105.00</b>
<b>NA535860HA</b>	1" body	2.9	<b>123.90</b>
<b>NA535861HA</b>	1" body, gauge	3.0	<b>135.50</b>
<b>NA535870HA</b>	1¼" body	6.1	<b>270.90</b>
<b>NA535871HA</b>	1¼" body, gauge	6.2	<b>282.50</b>
<b>NA535880HA</b>	1½" body	7.3	<b>382.20</b>
<b>NA535881HA</b>	1½" body, gauge	7.4	<b>393.80</b>
<b>NA535890HA</b>	2" body	9.7	<b>443.10</b>
<b>NA535891HA</b>	2" body, gauge	9.8	<b>455.70</b>



Replacement cartridge for 535H Series pressure reducer.

Code	Description	Lbs	USD
<b>535006HA</b>	Fits 535H ½", ¾", 1"	0.3	<b>65.70</b>
<b>535009HA</b>	Fits 535H 1¼", 1½", 2"	0.5	<b>198.00</b>

**PRESSURE REDUCING VALVES**



**533H PresCal™ Compact sweat**

Compact pressure reducing valve for residential and light commercial applications. DZR low lead body with inlet union connection. Low friction anti-scale moving parts. High flow seat design. Adjustment screw for pressure set point. Tamper-resistant cap included. Max. working pressure: 250 psi. Max. working temperature: 180°F. Pressure setting range: 15-80 psi. Factory setting: 45 psi.



**533H PresCal™ Compact press**

Compact pressure reducing valve for residential and light commercial applications. DZR low-lead brass body with inlet union connection. Low friction anti-scale moving parts. High flow seat design. Adjustment screw for pressure set point. Tamper-resistant cap included. Max. working pressure: 250 psi. Max. working temperature: 180°F. Pressure setting range: 15-80 psi. Factory setting: 45 psi.

Code	Description	Max GPM	Lbs	USD
533940HA*	1/2", sweat union in	5.6	2.0	<b>91.30</b>
533941HA**	1/2", sweat union in	5.6	2.1	<b>104.00</b>
533950HA*	3/4", sweat union in	10	2.3	<b>65.90</b>
533951HA**	3/4", sweat union in	10	2.4	<b>77.30</b>

\*FNPT outlet  
\*\*FNPT outlet with gauge

Code	Description	Max GPM	Lbs	USD
533640HA*	1/2", press union in	10	2.3	<b>99.00</b>
533641HA**	1/2", press union in	10	2.4	<b>115.00</b>
533650HA*	3/4", press union in	10	2.3	<b>65.90</b>
533651HA**	3/4", press union in	10	2.4	<b>77.30</b>

\*FNPT outlet  
\*\*FNPT outlet with gauge



**533H PresCal™ Compact NPT**

Compact pressure reducing valve for residential and light commercial applications. DZR low-lead brass body with inlet union connection. Low friction anti-scale moving parts. High flow seat design. Adjustment screw for pressure set point. Tamper-resistant cap included. Max. working pressure: 250 psi. Max. working temperature: 180°F. Pressure setting range: 15-80 psi. Factory setting: 45 psi.



**533H PresCal™ Compact PEX**

Compact pressure reducing valve for residential and light commercial applications. DZR low-lead brass body with inlet union connection. Low friction anti-scale moving parts. High flow seat design. PEX crimp: ASTM F1807. PEX expansion: ASTM F1960. Adjustment screw for pressure set point. Tamper-resistant cap included. Max. working pressure: 250 psi. Max. working temperature: 180°F. Pressure setting range: 15-80 psi. Factory setting: 45 psi.

Code	Description	Max GPM	Lbs	USD
533340HA*	1/2", NPT female union in	5.6	1.9	<b>100.00</b>
533341HA**	1/2", NPT female union in	5.6	2.0	<b>113.00</b>
533350HA*	3/4", NPT female union in	10	2.2	<b>65.90</b>
533351HA**	3/4", NPT female union in	10	2.3	<b>77.30</b>

\*FNPT outlet  
\*\*FNPT outlet with gauge

Code	Description	Max GPM	Lbs	USD
533750HA*	3/4", PEX crimp union in	10	2.3	<b>65.90</b>
533751HA**	3/4", PEX crimp union in	10	2.4	<b>77.30</b>
533850HA*	3/4", PEX expan union in	10	2.3	<b>65.90</b>
533851HA**	3/4", PEX expan union in	10	2.3	<b>77.30</b>

\*FNPT outlet  
\*\*FNPT outlet with gauge

Complies with: ASSE 1003, CSA B356, NSF/ANSI/CAN 61, NSF/ANSI/CAN 372, Low Lead Laws and listed by ICC-ES. Meets codes IPC, IRC & UPC for use in accordance with the U.S. and Canadian plumbing codes.

**PRESSURE REDUCING VALVES**

**Construction details 533H PresCal™**

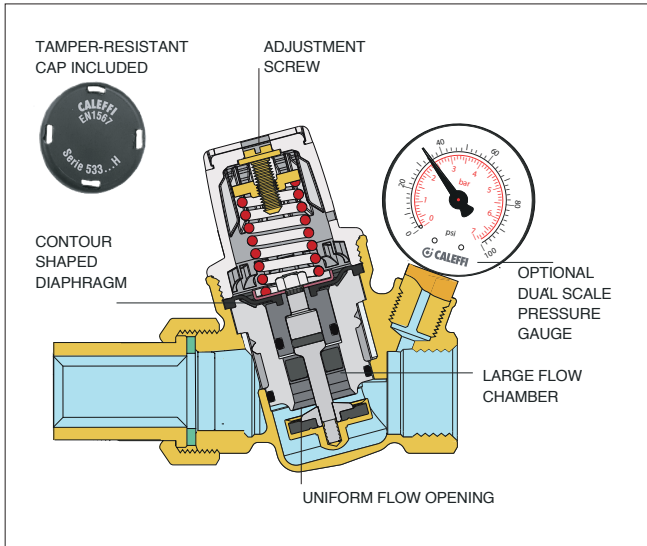

Replacement cartridge for 533H Series pressure reducer.

Code	Description	Lbs	USD
<b>533000H</b>	Fits 533H 1/2", 3/4"	0.2	<b>49.10</b>



**533H PresCal™ Body**

Replacement valve body.  
DZR low lead body.  
Gauge port plug NA10438 included with body.  
See fitting selection table in Section 8.

Code	Description	Lbs	USD
<b>NA533449HA</b>	1/2" body	0.7	<b>81.60</b>
<b>NA533459HA</b>	3/4" body	0.9	<b>86.30</b>

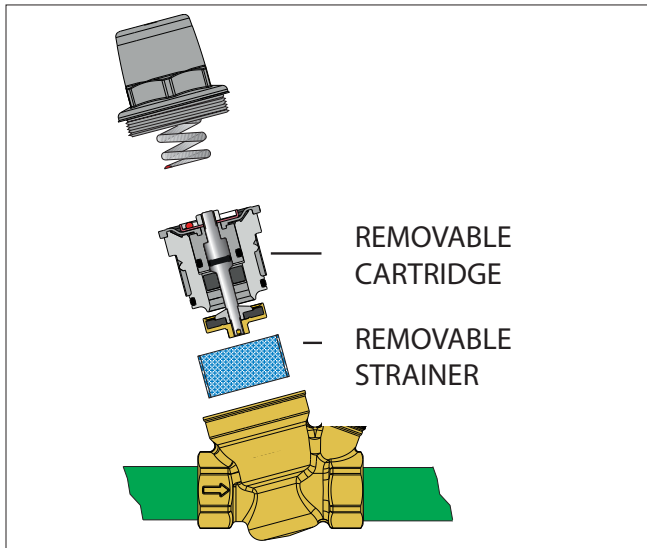

Pressure gauge fits 535H and 533H Series pressure reducers.  
Dial size: 2".  
Pressure range: 0—100 psi /0-7 bar.  
Connection: 1/8" NPT.

Code	Description	Lbs	USD
<b>NA10273</b>	1/8" NPT male	0.1	<b>14.60</b>

**PRESSURE REDUCING VALVES**



**536 PresCal™ HP sweat High Range**

High performance piston type pressure reducing valve for high rise buildings and other applications where high pressures are present and require staged pressure control. DZR low-lead brass body. Pressure gauge: 0-200 psi. Max. working pressure: 360 psi. Max. working temperature: 180°F. Pressure setting range: 90 – 150 psi. Factory setting: 115 psi



**536 PresCal™ HP NPT High Range**

High performance piston type pressure reducing valve for high rise buildings and other applications where high pressures are present and require staged pressure control. DZR low-lead brass body. Pressure gauge: 0-200 psi. Max. working pressure: 360 psi. Max. working temperature: 180°F. Pressure setting range: 90 – 150 psi. Factory setting: 115 psi

Code	Description	Max GPM	Lbs	USD
536043A 109	½" sweat	7.3	3.3	<b>321.00</b>
536053A 109	¾" sweat	12	4.4	<b>354.00</b>
536063A 109	1" sweat	19	5.0	<b>468.00</b>
536073A 109	1¼" sweat	34	7.5	<b>648.00</b>
536083A 109	1½" sweat	44	8.8	<b>793.00</b>
536093A 109	2" sweat	70	12	<b>1,020.00</b>

Code	Description	Max GPM	Lbs	USD
536043A 103	½" NPT female	7.3	3.3	<b>338.00</b>
536053A 103	¾" NPT female	12	4.4	<b>372.00</b>
536063A 103	1" NPT female	19	5.0	<b>491.00</b>
536073A 103	1¼" NPT female	34	7.5	<b>680.00</b>
536083A 103	1½" NPT female	44	8.8	<b>835.00</b>
536093A 103	2" NPT female	70	11	<b>1,073.00</b>

**NEW**



Gauge for high range. 2½" dial. ¼" CBM

Code	Description	Lbs	USD
NA10813	0-200 psi	0.4	<b>54.10</b>

**Application diagram**

The high range 536A PresCal HP is designed for 1st stage pressure control due to its adjustment range of 90 - 150 psi. The 2nd stage PRV is typically a diaphragm type, such as the 535H PresCal, with an adjustment range of 15 - 90 psi.

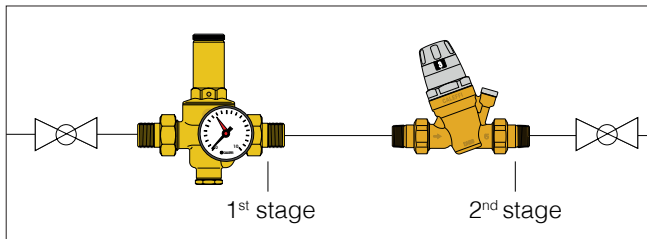

**Construction details 536 PresCal™ HP**

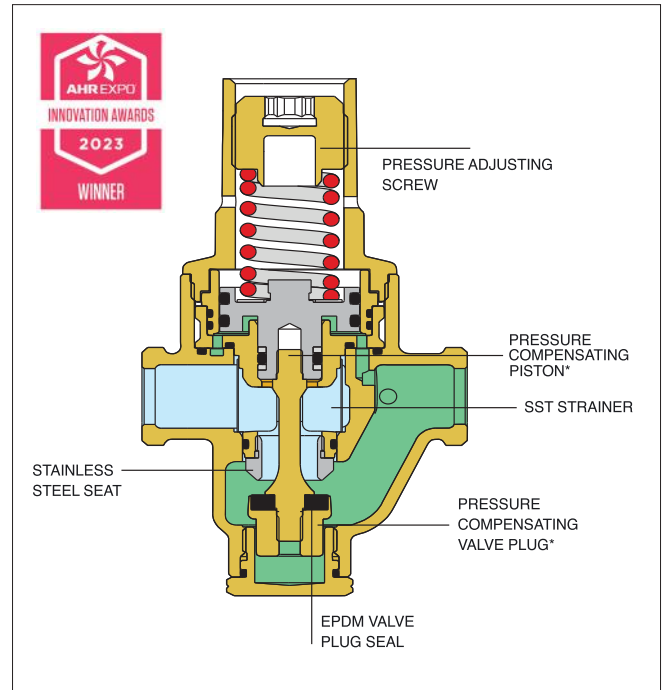

Complies with NSF/ANSI/CAN 372, Drinking Water System Components-Lead Content Reduction of Lead in Drinking Water Act, California Health and Safety Code 116875 S.3874, Reduction in Drinking Water Act, Vermont Act 193 - The Lead in Plumbing Supplies Law and Maryland's Lead Free Law HB.372, as certified by ICC-ES, file PMG-1360.



PRESSURE REDUCING VALVES



**536 PresCal™ HP sweat Low Range**

High performance piston type pressure reducing valve designed for demanding applications where water hammer and pressure spikes are present that would damage a diaphragm type PRV. DZR low-lead brass body. Pressure gauge: 0-100 psi. Max working pressure: 300 psi. Max working temperature: 180°F. Pressure setting range 10 - 90 psi. Factory setting 45 psi

Code	Description	Max GPM	Lbs	USD
536044A 109	1/2" sweat	7.3	3.3	321.00
536054A 109	3/4" sweat	12	4.4	354.00
536064A 109	1" sweat	19	5.0	468.00
536074A 109	1 1/4" sweat	34	7.5	648.00
536084A 109	1 1/2" sweat	44	8.8	793.00



**536 PresCal™ HP press Low Range**

High performance piston type pressure reducing valve designed for demanding applications where water hammer and pressure spikes are present that would damage a diaphragm type PRV. DZR low-lead brass body. Pressure gauge: 0-100 psi. Max working pressure: 300 psi. Max working temperature: 180°F. Pressure setting range 10 - 90 psi. Factory setting 45 psi

Code	Description	Max GPM	Lbs	USD
536044A 106	1/2" press	7.3	3.3	330.00
536054A 106	3/4" press	12	4.4	409.00
536064A 106	1" press	19	5.0	540.00
536074A 106	1-1/4" press	34	7.5	749.00
536084A 106	1-1/2" press	44	8.8	959.00

NEW



O-ring seal and NA10810 gauge adapter for 536A PresCal™ HP valves.

Code	Description	Lbs	USD
R57264*	O-ring seal	0.1	1.00
NA10810**	1/4" G male x 1/4" FNPT	0.3	24.90

\*for NA10810 gauge adapter for high and low range.  
\*\*Gauge adapter fitting for high and low range.

Function

The PresCal™HP 536A Series pressure reducing valve is a high performance true piston-type PRV that can withstand the punishing conditions of water hammer while ensuring high pressure reduction and control. Models 536x3A, with set point adjustment range 90 to 150 psi, provide the first stage of pressure reduction in a two-valve Series where the pressure ratio between the inlet and outlet would be too high for single PRV to control. Models 536x4A, also a piston PRV, comply with ASSE 1003, have a standard adjustment range of 10 to 90 psi and the all-metal design makes them ideal for outdoor locations and irrigation pressure control.



**536 PresCal™ HP NPT Low Range**

High performance piston type pressure reducing valve designed for demanding applications where water hammer and pressure spikes are present that would damage a diaphragm type PRV. DZR low-lead brass body. Pressure gauge: 0-100 psi. Max working pressure: 300 psi. Max working temperature: 180°F. Pressure setting range 10 - 90 psi. Factory setting 45 psi

Code	Description	Max GPM	Lbs	USD
536044A 103	1/2" NPT female	7.3	3.3	338.00
536054A 103	3/4" NPT female	12	4.4	372.00
536064A 103	1" NPT female	19	5.0	491.00
536074A 103	1-1/4" NPT female	34	7.5	680.00
536084A 103	1-1/2" NPT female	44	8.8	835.00

NEW



Gauge for low range. 2 1/2" dial. 1/4" CBM

Code	Description	Lbs	USD
NA10817	0-100 psi gauge, low range	0.4	52.50

Pressure compensating

Caleffi 536A Series pressure reducing valves are designed with a pressure balanced seat/plug. This ensures precise and constant controlled outlet pressure despite upstream pressure fluctuations. In the figure, the thrust towards the opening is counterbalanced by the force created by the closing pressure acting on the compensating piston. Since the piston has a surface area equal to that of the valve plug, the two forces cancel out each other.

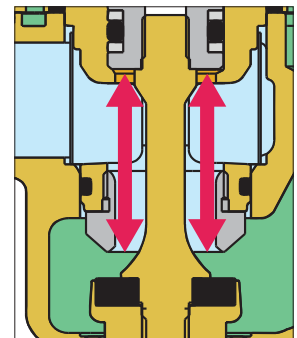

Complies with NSF/ANSI/CAN 372, Drinking Water System Components-Lead Content Reduction of Lead in Drinking Water Act, California Health and Safety Code 116875 S.3874, Reduction in Drinking Water Act, Vermont Act 193 - The Lead in Plumbing Supplies Law and Maryland's Lead Free Law HB.372, as certified by ICC-ES, file PMG-1360.

**BACKFLOW PREVENTERS, RPZ TYPE**

**574  
RPZ Backflow Preventer**



Testable reduced pressure zone backflow preventer.  
DZR low lead brass body.  
Max. working pressure: 150 psi.  
Max. working temperature: 150°F.

**574  
RPZ Backflow Preventer**



Testable reduced pressure zone backflow preventer.  
DZR low lead brass body.  
Max. working pressure: 150 psi.  
Max. working temperature: 150°F.

Code	Description	Lbs	USD
574004A	½" FNPT	5.0	<b>361.00</b>
574064A	½" press	5.1	<b>382.00</b>
59977*	Upstream check valve	0.1	<b>22.40</b>
59978*	Downstream check valve	0.2	<b>25.90</b>
59979*	Discharge valve assembly	0.1	<b>40.20</b>
NA11604**	Rebuild kit (½") incl. checks, disch valve	0.7	<b>80.00</b>
59980*	Discharge air gap	0.1	<b>54.10</b>
F0001006*	Test port valve (½" - 1")	0.2	<b>24.70</b>

\*Replacement  
\*\*Rebuild kit

**Function**

Caleffi 574 Series RPZ backflow preventers have dual unions for simple removal of the body for service or rebuilding. Access to the internal components from the top is also easy without removing the valve from the piping, if desired. Rebuild parts are available by ordering a single part number kit, for each size RPZ. The PT ports are located on top for easy access whether flow is right-to-left or left-to-right.

**Construction details ½" RPZ Backflow Preventer**

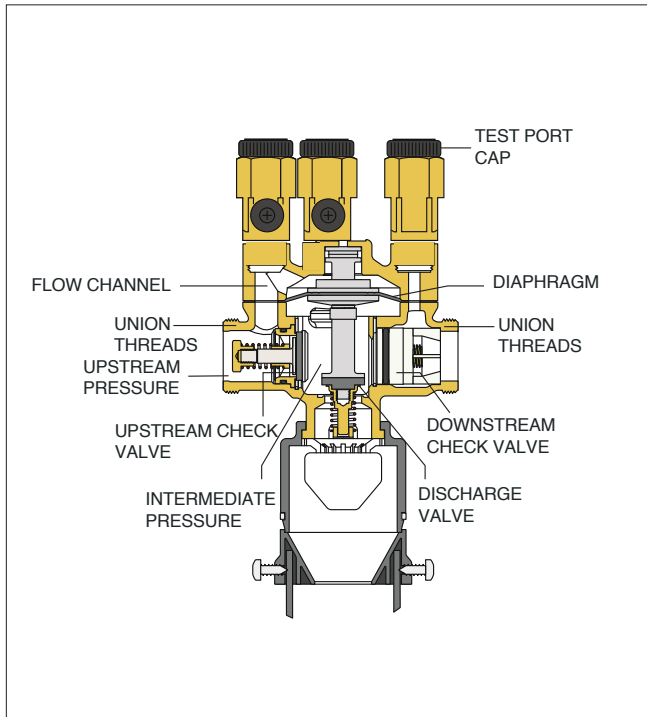

Code	Description	Lbs	USD
574050A	¾" FNPT	9.5	<b>433.00</b>
574056A	¾" press	9.6	<b>471.00</b>
59469*	Upstream check valve (¾")	0.2	<b>57.60</b>
59470*	Downstream check valve (¾")	0.2	<b>61.20</b>
59471*	Discharge valve assembly (¾")	0.3	<b>122.00</b>
59472*	Valve seat (¾")	0.1	<b>43.20</b>
NA11605**	Checks, disch valve, seat for (¾")	0.8	<b>258.00</b>
39623*	Discharge air gap (¾" to 2")	0.2	<b>59.50</b>
F0001006*	Test port valve (½" to 1")	0.2	<b>24.70</b>

\*Replacement  
\*\*Rebuild kit

**Function**

The backflow preventer can be used in all systems where there is danger of the potable water supply system being contaminated. It prevents an accidental reduction in the pressure in the distribution system from causing backflow from contaminated water in user installations.

**Construction details ¾ and 1" RPZ Backflow Preventer**

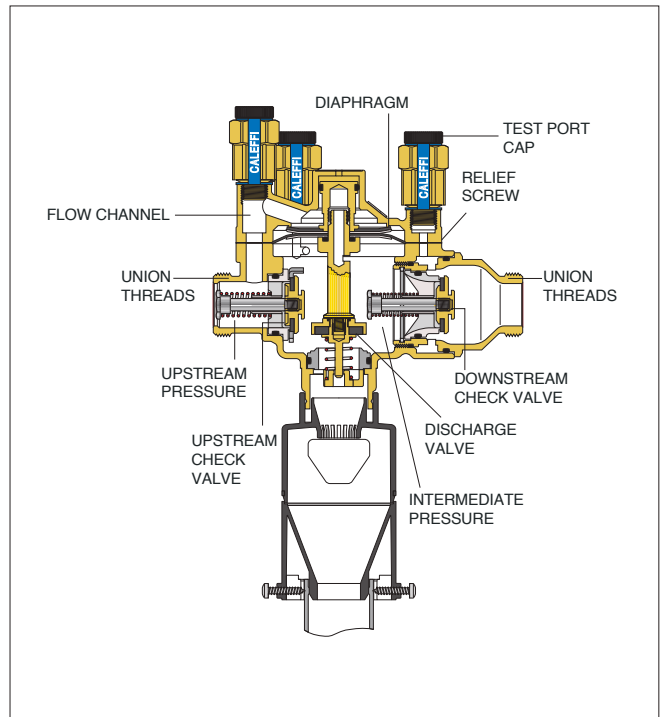

Complies with: ASSE 1013, CSA B64.4, NSF/ANSI/CAN 372, Low Lead Laws and listed by ICC-ES. Meets codes IPC, IRC & UPC for use in accordance with the U.S. and Canadian plumbing codes.

**BACKFLOW PREVENTERS, RPZ TYPE**

**574 RPZ Backflow Preventer**



Testable reduced pressure zone backflow preventer.  
DZR low lead brass body.  
Max. working pressure: 150 psi.  
Max. working temperature: 150°F.

Code	Description	Lbs	USD
574006A	1" FNPT	11	<b>451.00</b>
574066A	1" press	11	<b>501.00</b>
59455*	Upstream check valve (1")	0.3	<b>94.10</b>
59456*	Downstream check valve (1")	0.3	<b>94.10</b>
59471*	Discharge valve assembly (1")	0.3	<b>122.00</b>
59472*	Valve seat (1")	0.1	<b>43.20</b>
NA11606**	Checks, disch valve, seat (1")	0.1	<b>303.00</b>
39623*	Discharge air gap (3/4" to 2")	0.2	<b>59.50</b>
F0001006*	Test port valve (1/2" to 1")	0.2	<b>24.70</b>

\*Replacement  
\*\*Rebuild kit

**574 RPZ Backflow Preventer**



Testable reduced pressure zone backflow preventer.  
DZR low lead brass body.  
Max. working pressure: 150 psi.  
Max. working temperature: 150°F.

Code	Description	Lbs	USD
574700A	1 1/4" FNPT	14	<b>821.00</b>
574706A	1 1/4" press	14	<b>934.00</b>
59455*	Upstream check valve (1 1/4")	0.3	<b>94.10</b>
59456*	Downstream check valve (1 1/4")	0.3	<b>94.10</b>
59457*	Discharge valve assembly (1 1/4")	0.6	<b>133.00</b>
59458*	Valve seat (1 1/4")	0.2	<b>45.40</b>
NA11607**	Incl. checks, disch valve, seat for (1 1/4")	1.4	<b>367.00</b>
39623*	Discharge air gap (3/4" to 2")	0.2	<b>59.50</b>
F0001901	Test port valve (1 1/4" to 2")	0.2	<b>20.10</b>

\*Replacement  
\*\*Rebuild kit

**574 RPZ Backflow Preventer**



Testable reduced pressure zone backflow preventer.  
DZR low lead brass body.  
Max. working pressure: 150 psi.  
Max. working temperature: 150°F.

Code	Description	Lbs	USD
574801A	1 1/2" FNPT	14	<b>887.00</b>
574806A	1 1/2" press	14	<b>1,006.00</b>
59455*	Upstream check valve (1 1/2")	0.3	<b>94.10</b>
59456*	Downstream check valve (1 1/2")	0.6	<b>94.10</b>
59457*	Discharge valve assembly (1 1/2")	0.6	<b>133.00</b>
59458*	Valve seat (1 1/2")	0.2	<b>45.40</b>
NA11608**	incl. checks, disch valve, seat for (1 1/2")	1.4	<b>367.00</b>
39623*	Discharge air gap (3/4" to 2")	0.2	<b>59.50</b>
F0001901	Test port valve (1 1/4" to 2")	0.2	<b>20.10</b>

\*Replacement  
\*\*Rebuild kit

**574 RPZ Backflow Preventer**



Testable reduced pressure zone backflow preventer.  
DZR low lead brass body.  
Max. working pressure: 150 psi.  
Max. working temperature: 150°F.

Code	Description	Lbs	USD
574900A	2" FNPT	20	<b>1,396.00</b>
574906A	2" press	20	<b>1,606.00</b>
59459*	Upstream check valve (2")	0.4	<b>152.00</b>
59460*	Downstream check valve (2")	0.4	<b>135.00</b>
59461*	Discharge valve assembly (2")	0.7	<b>258.00</b>
59462*	Valve seat (2")	0.3	<b>51.90</b>
NA11609**	incl. checks, disch valve, seat for (2")	1.8	<b>709.00</b>
39623*	Discharge air gap (3/4" to 2")	0.2	<b>59.50</b>
F0001901	Test port valve (1 1/4" to 2")	0.2	<b>20.10</b>

\*Replacement  
\*\*Rebuild kit

**Construction details 1 1/4" and 1 1/2" RPZ Backflow Preventer**

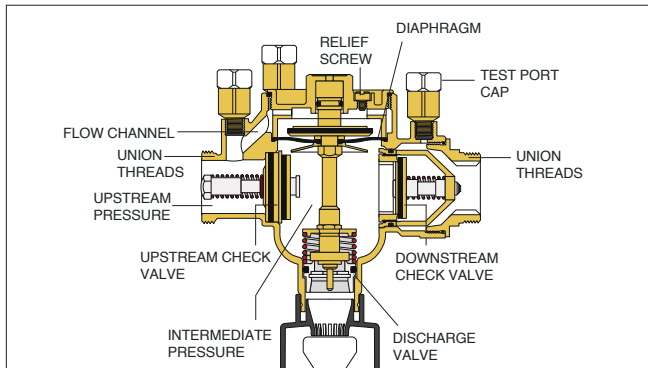

**Construction details 2" RPZ Backflow Preventer**

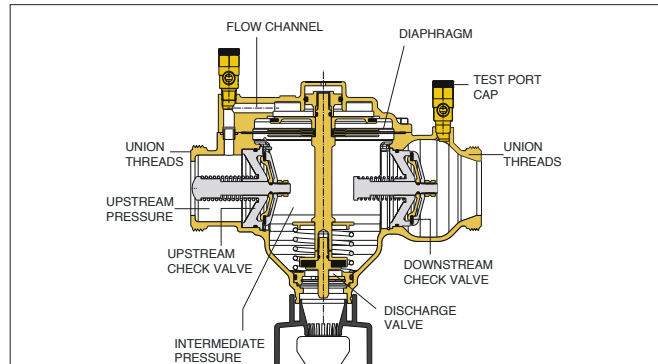

Complies with: ASSE 1013, CSA B64.4, NSF/ANSI/CAN 372, Low Lead Laws and listed by ICC-ES. Meets codes IPC, IRC & UPC for use in accordance with the U.S. and Canadian plumbing codes.

**BACKFLOW PREVENTERS, DUAL CHECK**

**NEW**

**3048  
Dual Check Backflow  
Preventer sweat**



Serviceable inline spring check valves.  
DZR low-lead brass body.  
Max working pressure 160 psi (11 bar).  
Operating temperature range 32° – 150° F

Code	Description	Lbs	USD
<b>304849A</b>	½" sweat	1.2	<b>79.00</b>
<b>304859A</b>	¾" sweat	1.6	<b>80.00</b>
<b>304869A</b>	1" sweat	1.6	<b>89.00</b>

**Function**

Dual check backflow preventer for residential domestic water supply lines or commercial low-hazard backflow applications, wherever **ASSE 1024** backflow preventers are approved.

**NEW**

**3048  
Dual Check Backflow  
Preventer PEX**



Serviceable inline spring check valves.  
DZR low-lead brass body.  
Max working pressure 160 psi (11 bar).  
Operating temperature range 32° – 150° F  
PEX crimp: ASTM F1807.  
PEX expansion: ASTM F1960.

Code	Description	Lbs	USD
<b>304847A</b>	½" PEX crimp	1.0	<b>79.00</b>
<b>304848A</b>	½" PEX expansion	1.0	<b>79.00</b>
<b>304857A</b>	¾" PEX crimp	1.2	<b>80.00</b>
<b>304858A</b>	¾" PEX expansion	1.2	<b>80.00</b>
<b>304867A</b>	1" PEX crimp	1.4	<b>89.00</b>
<b>304868A</b>	1" PEX expansion	1.4	<b>89.00</b>

**NEW**

**3048  
Dual Check Backflow  
Preventer MNPT**



Serviceable inline spring check valves.  
DZR low-lead brass body.  
Max working pressure 160 psi (11 bar).  
Operating temperature range 32° – 150° F

Code	Description	Lbs	USD
<b>304840A</b>	½" MNPT	1.0	<b>85.00</b>
<b>304850A</b>	¾" MNPT	1.2	<b>86.00</b>
<b>304860A</b>	1" MNPT	1.6	<b>94.00</b>

**NEW**

**3048  
Dual Check Backflow  
Preventer press**



Serviceable inline spring check valves.  
DZR low-lead brass body.  
Max working pressure 160 psi (11 bar).  
Operating temperature range 32° – 150° F

Code	Description	Lbs	USD
<b>304846A</b>	½" press	1.0	<b>92.00</b>
<b>304856A</b>	¾" press	1.2	<b>93.00</b>
<b>304866A</b>	1" press	1.4	<b>102.00</b>

**NEW**

**3048  
Dual Check Backflow  
Preventer FNPT**



Serviceable inline spring check valves.  
DZR low-lead brass body.  
Max working pressure 160 psi (11 bar).  
Operating temperature range 32° – 150° F

Code	Description	Lbs	USD
<b>304843A</b>	½" FNPT	1.2	<b>85.00</b>
<b>304853A</b>	¾" FNPT	1.6	<b>86.00</b>

**Construction details**

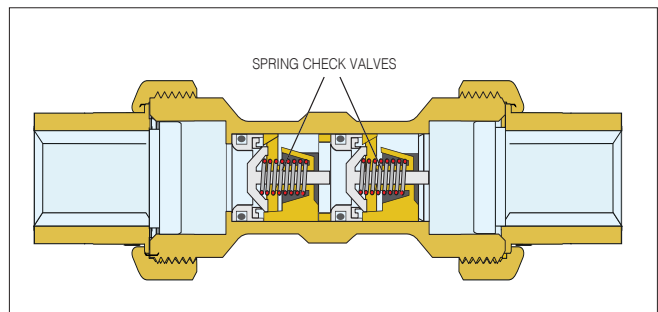

Complies with the requirement of ASSE 1024 and NSF/ANSI/CAN 372, Low Lead Laws and listed by ICC-ES. Meets codes IPC, IRC & UPC for use in accordance with the U.S. and Canadian plumbing codes.

**BACKFLOW PREVENTERS, DUAL CHECK**



**573 Dual Check Backflow Preventer**

Dual check continuous pressure backflow preventer with atmospheric vent.  
 DZR low Lead brass body.  
 Max. working pressure: 175 psi.  
 Working temperature range: 32°–250°F.  
 Emergency backpressure temperature: 250°F.  
 Certified to: ASSE 1012, CSA B64.3, NSF/ANSI/CAN 372, Low Lead Laws and listed by ICC-ES. Meets codes IPC, IRC & UPC for use in accordance with the U.S. and Canadian plumbing codes.

**Construction details**

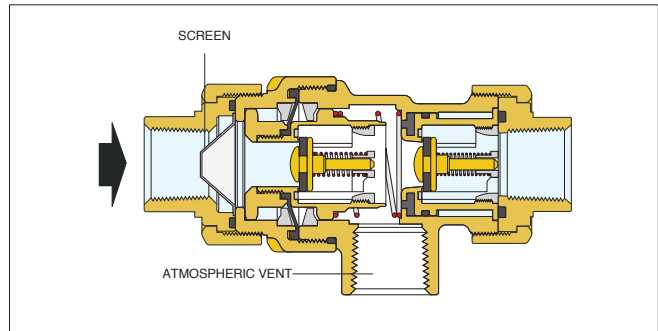

Code	Description	Lbs	USD
573403A	1/2" NPT female unions	1.7	97.50
573406A	1/2" press unions	1.7	119.00
573409A	1/2" sweat unions	1.7	92.70
573493A	1/2" sweat union inlet, 1/2" FNPT union outlet	1.7	95.40
573503A	3/4" NPT female unions	1.7	102.00
573100A*	Replacement body w/washers	1.5	71.60

\*See fitting selection table in Section 8

**VACUUM RELIEF VALVE**

**NEW**



**304 Vacuum Relief Valve (VRV)**

Vacuum relief valves automatically allow air to enter into the piping system to prevent vacuum conditions that could siphon the water from the system and damage water heater/tank equipment. VRVs are suitable for water and low pressure steam service and are ideal for use in water heaters and supply tanks, table top heaters, jacketed steam kettles, unit heaters, low pressure steam systems, and steam coil heaters.

DZR low-lead brass body.  
 Max working pressure 160 psi.  
 Operating temperature range 32° – 150°F.

Code	Description	Lbs	USD
304040A	1/2" MNPT	0.8	35.00
304050A	3/4" MNPT	0.8	38.00

**Application diagram**

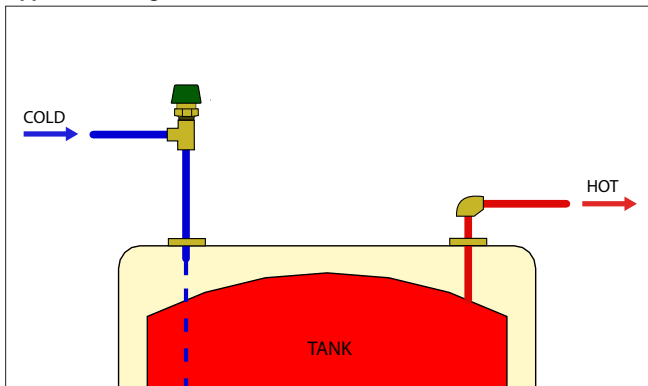

**Construction details**

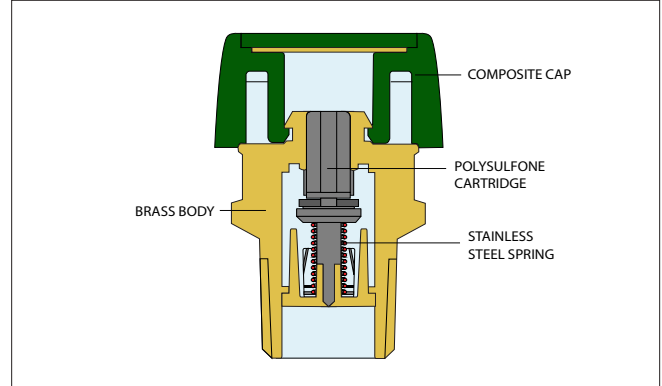

Approvals: ANSI 21.22-2015, ANSI/NSF/CAN 372 low lead lead laws and ANSI/NSF/CAN 61 certified by ICC-ES.

# PLUMBVENT™ LOW LEAD AIR VENT



**PLUMBVENT™** is the market's **only** low lead air vent designed to automatically remove air from domestic water at high points in plumbing systems. As water within the system warms, air naturally comes out of solution. It can accumulate into air pockets, risking efficient pump performance. PLUMBVENT ensures reliable recirculation flow. **Approvals include compliance with U.S. and Canadian plumbing codes. CALEFFI GUARANTEED.**



# PLUMBING MISCELLANEOUS COMPONENTS

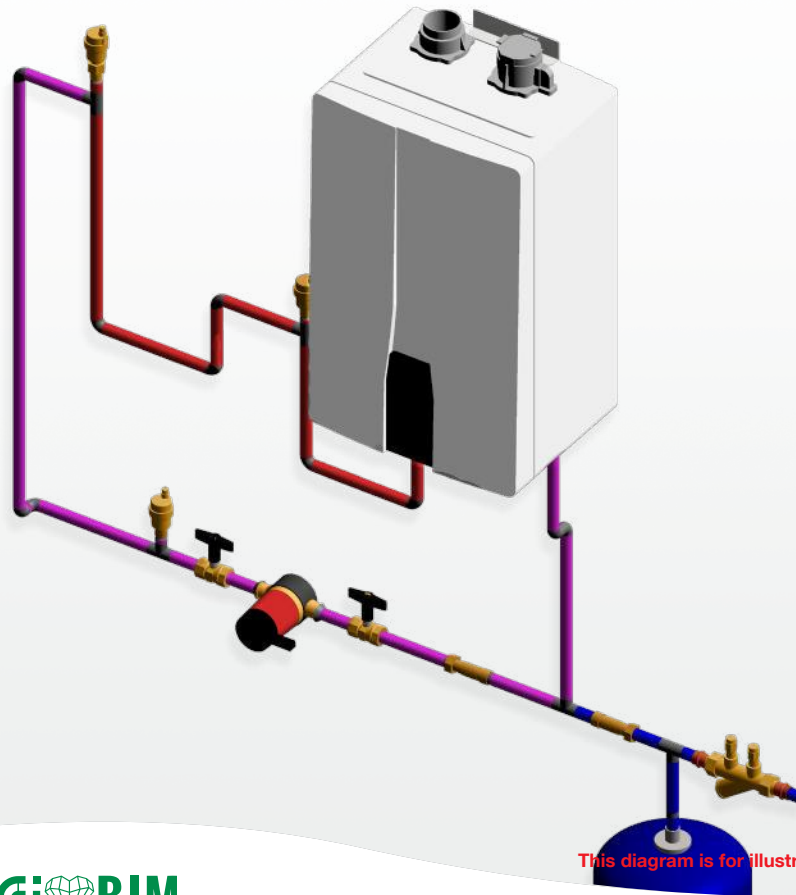

 **BIM**  
bim.caleffi.com

## PRODUCTS INCLUDED IN SECTION

- Union Y-strainers for plumbing and hydronics
- Y-strainer with ball valve for hydronics
- Isolation ball valves
- Tankless water heater service valve kit
- Serviceable low lead check valves
- Automatic air vent for plumbing

**UNION Y-STRAINERS FOR PLUMBING AND HYDRONICS**

**NEW**



**128 Y-strainer sweat**

Y-strainer with union connections. PT ports included. 1/2" FNPT plugged blowdown port. Max. working pressure: 400 psi. Temperature range: 32°–212°F. Max. percentage of glycol: 50%

Code	Description	Lbs	USD
128749A 000	Union strainer 1/2" sweat, PT ports	1.3	<b>133.00</b>
128759A 000	Union strainer 3/4" sweat, PT ports	1.5	<b>136.00</b>
128769A 000	Union strainer 1" sweat, PT ports	1.7	<b>141.00</b>

**NEW**



**128 Y-strainer PEX**

Y-strainer with union connections. PT ports included. 1/2" FNPT plugged blowdown port. Max. working pressure: 400 psi. Temperature range: 32°–212°F. Max. percentage of glycol: 50%

Code	Description	Lbs	USD
128744A 000	Union strainer 1/2" PEX crimp, PT ports	1.5	<b>137.00</b>
128754A 000	Union strainer 3/4" PEX crimp, PT ports	1.5	<b>141.00</b>
128764A 000	Union strainer 1" PEX crimp, PT ports	1.7	<b>143.00</b>
128742A 000	Union strainer 1/2" PEX expan., PT ports	1.5	<b>137.00</b>
128752A 000	Union strainer 3/4" PEX expan., PT ports	1.5	<b>141.00</b>
128762A 000	Union strainer 1" PEX expan., PT ports	1.7	<b>143.00</b>

**NEW**



**128 Y-strainer NPT**

Y-strainer with union connections. PT ports included. 1/2" FNPT plugged blowdown port. Max. working pressure: 400 psi. Temperature range: 32°–212°F. Max. percentage of glycol: 50%

Code	Description	Lbs	USD
128741A 000	Union strainer 1/2" NPT male, PT ports	1.5	<b>144.00</b>
128751A 000	Union strainer 3/4" NPT male, PT ports	1.5	<b>147.00</b>
128761A 000	Union strainer 1" NPT male, PT ports	1.7	<b>149.00</b>

**NEW**



**128 Y-strainer press**

Y-strainer with union connections. PT ports included. 1/2" FNPT plugged blowdown port. Max. working pressure: 400 psi. Temperature range: 32°–212°F. Max. percentage of glycol: 50%

Code	Description	Lbs	USD
128746A 000	Union strainer 1/2" press, PT ports	1.5	<b>153.00</b>
128756A 000	Union strainer 3/4" press, PT ports	1.5	<b>157.00</b>
128766A 000	Union strainer 1" press, PT ports	1.7	<b>166.00</b>

**Construction details**

The 128 Series Y-strainer uses the same brass body as the 128 Series FlowCal balancing valve, with dual unions and PT ports included. The 20 mesh stainless steel screen can be easily removed for cleaning without removing the body from the piping or a 1/2" purge valve can replace the plug for easy dirt blowdown.

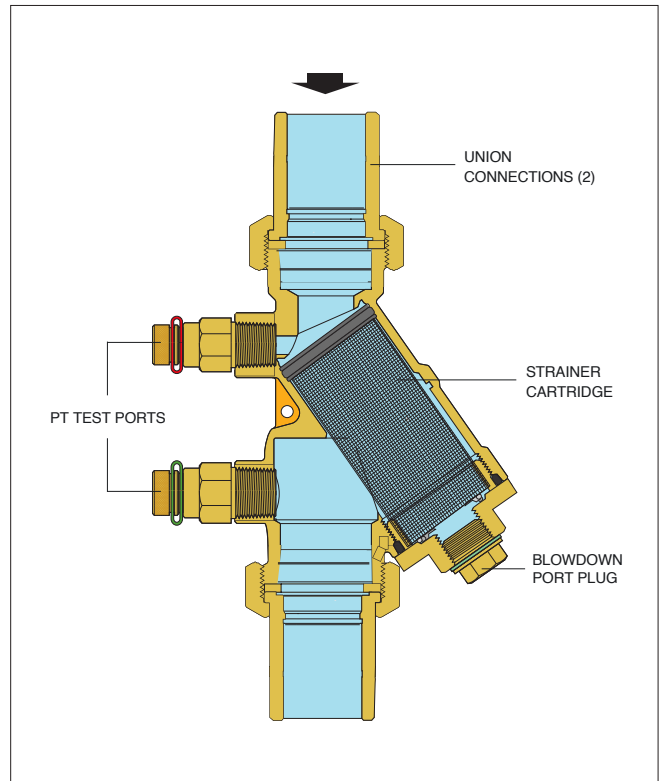



**Y-STRAINER WITH BALL VALVE FOR HYDRONICS**



**120 Y-strainer**

Y-strainer with integral ball valve for hydronic applications only, not for plumbing.  
 Brass body.  
 Stainless steel strainer cartridge.  
 Maximum working pressure: 400 psi (400 WOG).  
 Working temperature range: 32°–212°F.  
 Max. percentage glycol: 50%.  
 Strainer (20 mesh).  
 Connections: —body: FNPT union x FNPT, sweat union x sweat.  
 Pressure and temperature ports: ¼" NPT.  
 Drain port connection: ¼" for ½" & ¾" or ½" for 1" & 1¼".

Code	Description	Cv	Lbs	USD
<b>120141A 000</b>	½" NPT female	8.0	3.0	<b>129.00</b>
<b>120149A 000</b>	½" sweat	8.0	3.0	<b>123.00</b>
<b>120151A 000</b>	¾" NPT female	8.4	3.0	<b>130.00</b>
<b>120159A 000</b>	¾" sweat	8.4	3.0	<b>124.00</b>
<b>120161A 000</b>	1" NPT female	19	6.0	<b>258.00</b>
<b>120169A 000</b>	1" sweat	19	6.0	<b>245.00</b>
<b>120171A 000</b>	1¼" NPT female	20	6.0	<b>294.00</b>
<b>120179A 000</b>	1¼" sweat	20	6.0	<b>280.00</b>
<b>120341A 000</b>	½" NPT female with PT	8.0	3.5	<b>139.00</b>
<b>120349A 000</b>	½" sweat with PT	8.0	3.5	<b>134.00</b>
<b>120351A 000</b>	¾" NPT female with PT	8.4	3.5	<b>141.00</b>
<b>120359A 000</b>	¾" sweat with PT	8.4	3.5	<b>135.00</b>
<b>120361A 000</b>	1" NPT female with PT	19	6.5	<b>269.00</b>
<b>120369A 000</b>	1" sweat with PT	19	6.5	<b>255.00</b>
<b>120371A 000</b>	1¼" NPT female with PT	20	6.5	<b>304.00</b>
<b>120379A 000</b>	1¼" sweat with PT	20	6.5	<b>290.00</b>

**Construction details**

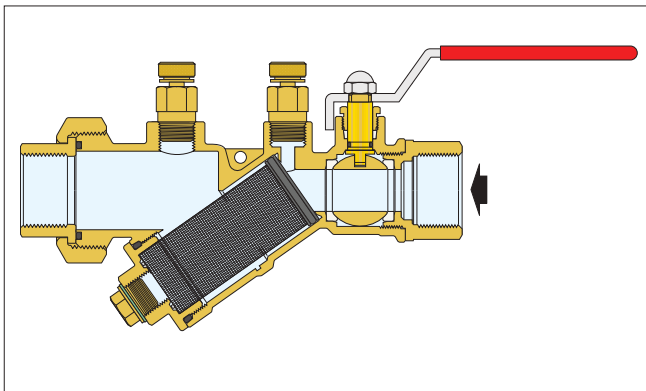

**DRAIN VALVES AND PT PORTS**



Drain valves for field installation in blow-down-port connection of the 120 Series Y-strainer.  
 Brass body.  
 With ¾" garden hose connection.  
 Max. working pressure: 150 psi.  
 Max. working temperature: 250°F.

Code	Description	Lbs	USD
<b>538202 FD</b>	¼" NPT fits ½–¾" 120 Series	0.3	<b>15.20</b>
<b>538402 FD</b>	½" NPT fits 1–1¼" 120 Series	0.3	<b>15.60</b>



Fast-plug pressure/temperature test ports fits FlowCal™ automatic flow balancing valves and the 120 Series Y-strainer. The double-sealing core insures long and trouble free service.  
 Low Lead brass body.  
 Nordel Core.  
 Connections: ¼" NPT male.  
 Cap thread: ⅜"-24 UNF.  
 Working temperature range: 0°–275°F.  
 Max. working pressure: 435 psi.  
 Pair (2 ports included).

Code	Description	Lbs	USD
<b>100001A</b>	Standard size, 1½" length (pair)	0.5	<b>16.10</b>

**ISOLATION BALL VALVES**



**290  
Isolation Valve**

Isolation ball valve.  
Low lead MxF union fits between valve body and tailpiece.

Code	Description	Lbs	USD
<b>290030</b>	1" M x 1" F union ball valve	1.0	<b>47.60</b>
<b>NA10815</b>	Stem extension for 290030	0.2	<b>27.10</b>

Example: 290 valves on 520 and 521 series mixing valves

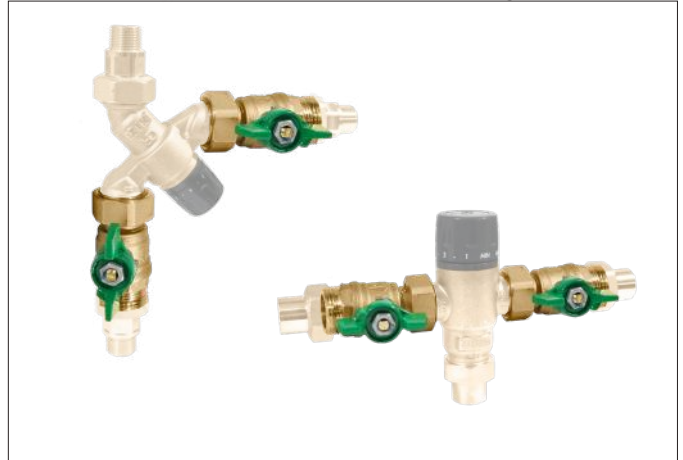

**NA108**

NPT full port ball valves with extended operator handle for insulated or bare pipes. For use with hot or cold water piping in plumbing or hydronic applications. High strength forged low lead brass. Blowout-proof stem with dual o-ring seals. Pressure rating 600 WOG. Temperature rating -4° — 366°F.

Code	Description	Lbs	USD
<b>NA10824</b>	½" FNPT ball valve low lead	0.4	<b>38.40</b>
<b>NA10825</b>	¾" FNPT ball valve low lead	0.6	<b>47.10</b>
<b>NA10826</b>	1" FNPT ball valve low lead	1.0	<b>61.10</b>
<b>NA10827</b>	1¼" FNPT ball valve low lead	1.6	<b>102.00</b>
<b>NA10828</b>	1½" FNPT ball valve low lead	1.9	<b>129.00</b>
<b>NA10829</b>	2" FNPT ball valve low lead	3.0	<b>314.00</b>

Example: NA108 valves + nipples on 116 series balancing valves



Low lead brass pipe nipples.  
For connecting NA108 ball valve to other FNPT valves such as 130, 132, 142, 116 Series.

Code	Description	Lbs	USD
<b>NA10834</b>	½" NPT nipple	0.1	<b>4.80</b>
<b>NA10835</b>	¾" NPT nipple	0.1	<b>7.60</b>
<b>NA10836</b>	1" NPT nipple	0.1	<b>11.90</b>
<b>NA10837</b>	1¼" NPT nipple	0.3	<b>20.60</b>
<b>NA10838</b>	1½" NPT nipple	0.3	<b>21.60</b>
<b>NA10839</b>	2" NPT nipple	0.5	<b>31.40</b>

**TANKLESS WATER HEATER SERVICE VALVE KIT**

2<sup>nd</sup> QTR



**290 Tankless Water Heater Service Valve Kit**

Tankless water heater service valves have union connections that attach directly to 3/4" water heater MNPT nipples. Isolation valves and 3/4" garden hose connections allow for flushing and servicing the water heater. A pressure relief valve, set to 150 psi, is included with each kit. DZR low lead brass body. Max working pressure 400 psi (27 bar). Operating temperature range 32° – 210°F (0° – 100°C).

Code	Description	Lbs	USD
290503A	3/4" FNPT service valve kit	2.0	156.00

**Construction details**

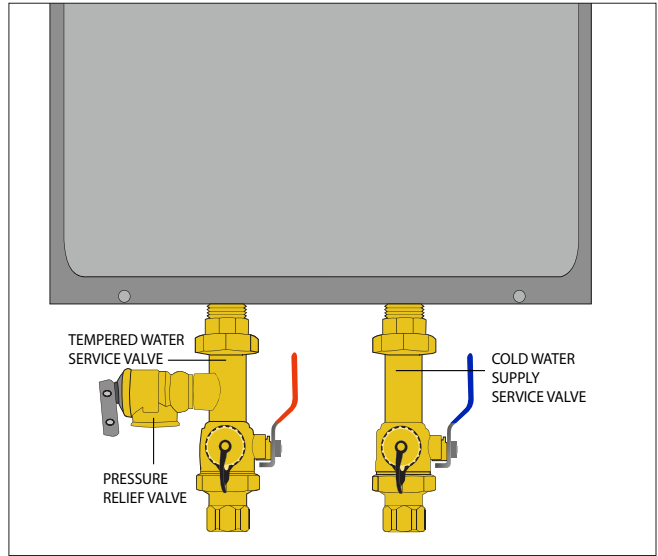

The tankless water heater service valve kit is available standalone (shown) or with the 520 Series TankMixer thermostatic mixing valve assembly.

2<sup>nd</sup> QTR



**290 Service Valve Kit with 520 TankMixer™**

Relief valve and temperature gauge are included with the kit. DZR low lead brass body CW724R. Max working pressure 400 psi (27 bar). Operating temperature range 32° – 210°F

Code	Description	Lbs	USD
290516A	3/4" press	5.0	475.00
290519A	3/4" sweat	5.0	456.00
290510A	3/4" FNPT	5.0	467.00
290517A	3/4" PEX crimp	5.0	456.00
290518A	3/4" PEX exp	5.0	456.00

**Construction details for TankMixer™ Kit**

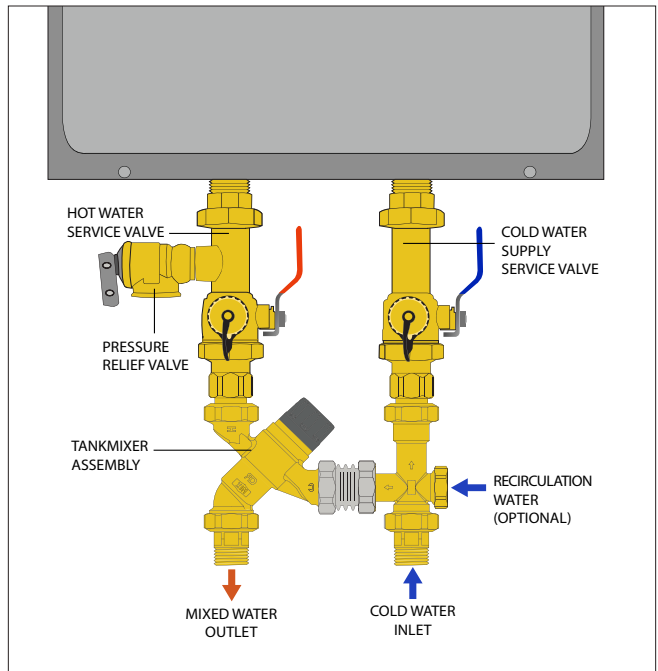

**SERVICEABLE LOW LEAD CHECK VALVES**



**NA51 sweat**

Serviceable low lead check valve.  
 Max. working pressure: 150 psi (10 bar).  
 Operating temperature range: 32° – 150°F (0° – 65°C).  
 Max. temperature: for one hour: 190°F (88°C).  
 Opening pressure differential: 0.25 psi (½" through 1¼"); 0.50 psi (1½", 2").

Code	Description	Cv	Lbs	USD
<b>NA51249</b>	½" sweat	17	0.4	<b>79.00</b>
<b>NA51259</b>	¾" sweat	17	0.4	<b>86.70</b>
<b>NA51369</b>	1" sweat	30	0.9	<b>123.00</b>
<b>NA51379</b>	1¼" sweat	30	1.1	<b>138.00</b>
<b>NA51489</b>	1½" sweat	75	2.4	<b>344.00</b>
<b>NA51499</b>	2" sweat	75	2.4	<b>366.00</b>



**NA51 MNPT**

Serviceable low lead check valve.  
 Max. working pressure: 150 psi (10 bar).  
 Operating temperature range: 32° – 150°F (0° – 65°C).  
 Max. temperature: for one hour: 190°F (88°C).  
 Opening pressure differential: 0.25 psi (½" through 1¼"); 0.50 psi (1½", 2").

Code	Description	Cv	Lbs	USD
<b>NA51240</b>	½" MNPT	17	0.4	<b>94.30</b>
<b>NA51250</b>	¾" MNPT	17	0.6	<b>99.50</b>
<b>NA51360</b>	1" MNPT	30	1.1	<b>130.00</b>
<b>NA51370</b>	1¼" MNPT	30	1.3	<b>143.00</b>
<b>NA51480</b>	1½" MNPT	75	2.6	<b>366.00</b>
<b>NA51490</b>	2" MNPT	75	2.6	<b>388.00</b>



**NA51 FNPT**

Serviceable low lead check valve.  
 Max. working pressure: 150 psi (10 bar).  
 Operating temperature range: 32° – 150°F (0° – 65°C).  
 Max. temperature: for one hour: 190°F (88°C).  
 Opening pressure differential: 0.25 psi (½" through 1¼"); 0.50 psi (1½", 2").

Code	Description	Cv	Lbs	USD
<b>NA51243</b>	½" FNPT	17	0.4	<b>107.00</b>
<b>NA51253</b>	¾" FNPT	17	0.6	<b>114.00</b>
<b>NA51363</b>	1" FNPT	30	1.1	<b>138.00</b>
<b>NA51373</b>	1¼" FNPT	30	1.3	<b>150.00</b>
<b>NA51493</b>	2" FNPT	75	2.6	<b>403.00</b>



**NA51 press**

Serviceable low lead check valves  
 Max. working pressure: 150 psi (10 bar).  
 Operating temperature range: 32° – 150°F (0° – 65°C).  
 Max. temperature: for one hour: 190°F (88°C).  
 Opening pressure differential: 0.25 psi (½" through 1¼"); 0.50 psi (1½", 2").

Code	Description	Cv	Lbs	USD
<b>NA51246</b>	½" press	17	0.4	<b>114.00</b>
<b>NA51256</b>	¾" press	17	0.6	<b>123.00</b>
<b>NA51366</b>	1" press	30	1.1	<b>178.00</b>
<b>NA51376</b>	1-¼" press	30	1.3	<b>209.00</b>
<b>NA51486</b>	1½" press	75	2.6	<b>451.00</b>
<b>NA51496</b>	2" press	75	2.6	<b>495.00</b>



**NA51 PEX**

Serviceable low lead check valve.  
 Max. working pressure: 150 psi (10 bar).  
 Operating temperature range: 32° – 150°F (0° – 65°C).  
 Max. temperature: for one hour: 190°F (88°C).  
 Opening pressure differential: 0.25 psi (½" through 1¼"); 0.50 psi (1½", 2").  
 PEX crimp: ASTM F1807  
 PEX expansion: ASTM F1960

Code	Description	Cv	Lbs	USD
<b>NA51247</b>	½" PEX crimp	17	0.4	<b>86.70</b>
<b>NA51257</b>	¾" PEX crimp	17	0.6	<b>94.30</b>
<b>NA51248</b>	½" PEX expansion	17	0.4	<b>86.70</b>
<b>NA51258</b>	¾" PEX expansion	17	0.6	<b>94.30</b>



**NA51 body**

Serviceable low lead check valve without fittings.  
 Max. working pressure: 150 psi (10 bar).  
 Operating temperature range: 32° – 150°F (0° – 65°C).  
 Max. temperature: for one hour: 190°F (88°C).  
 Opening pressure differential: 0.25 psi (½" through 1¼"); 0.50 psi (1½", 2").

Code	Description	Cv	Lbs	USD
<b>NA51200</b>	½", ¾" body, small	17	0.2	<b>56.00</b>
<b>NA51300</b>	1", 1¼" body, medium	30	0.5	<b>71.40</b>
<b>NA51400</b>	1½", 2" body, large	75	1.8	<b>186.00</b>



Replacement checks.

Code	Description	Cv	Lbs	USD
<b>NA10117</b>	Fits ½", ¾" (small body)	17	0.1	<b>10.30</b>
<b>NA10370</b>	Fits 1", 1¼" (medium body)	30	0.1	<b>10.30</b>
<b>NA10371</b>	Fits 1½", 2" (large body)	75	0.2	<b>17.80</b>

**AUTOMATIC AIR VENT FOR PLUMBING**



**NA5026  
PLUMBVENT™**

Automatic air vent with low lead brass body.  
 Compatible with plumbing systems.  
 Hygroscopic cap (anti-drip).  
 Max. working pressure: 150 psi.  
 Max. discharge pressure: 90 psi.  
 Max. discharge rate: 1.75 SCFM.  
 Max working temperature: 240°F.  
 Approval: NSF/ANSI/CAN 372 low lead.

**Function**

Float type automatic air vent designed to vent air from water at high points in plumbing system piping. Example applications include risers, domestic hot water storage tanks and recirculation system pump inlets. The automatic air vent is installed in the vertical position in parts of the system where air can accumulate and cause circulator air-lock or reduced efficiency. It is supplied complete with a safety hygroscopic cap that automatically closes the air discharge in case of contact with water.

Code	Description	Lbs	USD
<b>NA502640A</b>	1/2" MNPT	0.6	<b>50.00</b>

**Application Diagram**

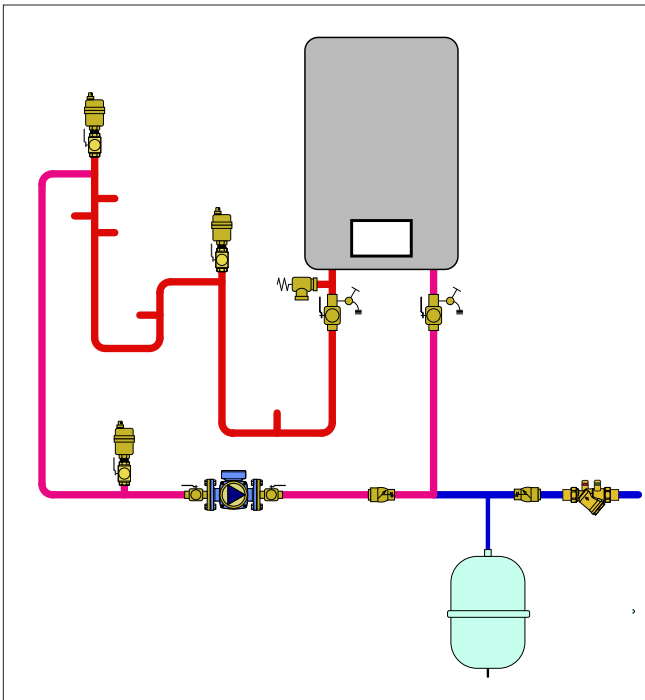

**Construction details**

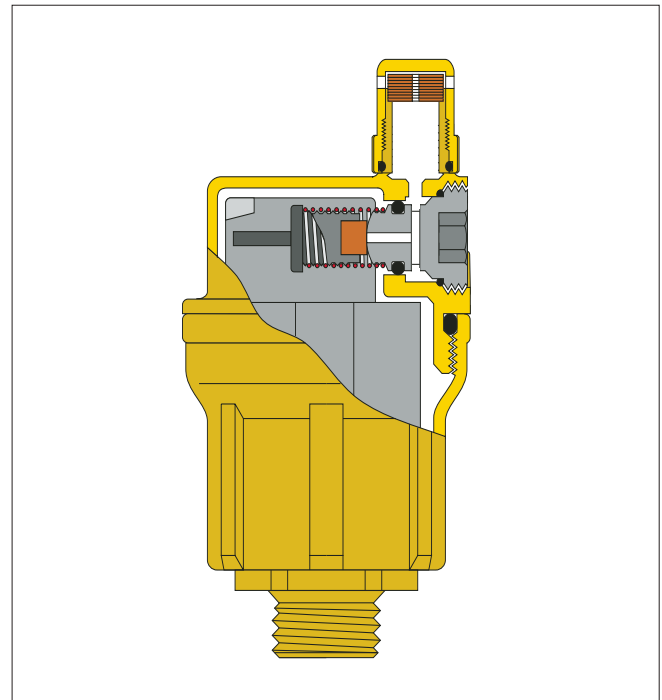

Complies with NSF/ANSI/CAN 372, Drinking Water System Components-Lead Content Reduction of Lead in Drinking Water Act, California Health and Safety Code 116875 S.3874, Reduction in Drinking Water Act, Vermont Act 193 - The Lead in Plumbing Supplies Law and Maryland's Lead Free Law HB.372, as certified by ICC-ES, file PMG-1360.

# AUTOFILL™ SET IT AND FORGET IT



The highly regarded and widely used **AutoFill™** is known among contractors as the **Set It and Forget It** hydronic system pressure control valve solution. The **fast-fill function** simplifies system fill by automatically opening fully until fill pressure is reached. System pressure is automatically maintained with set point dial or integral shutoff valve that can be closed for system isolation. The **AutoFill Combo** is conveniently available with an **ASSE 1012** dual check type or **ASSE 1013** RPZ backflow preventer. **CALEFFI GUARANTEED.**



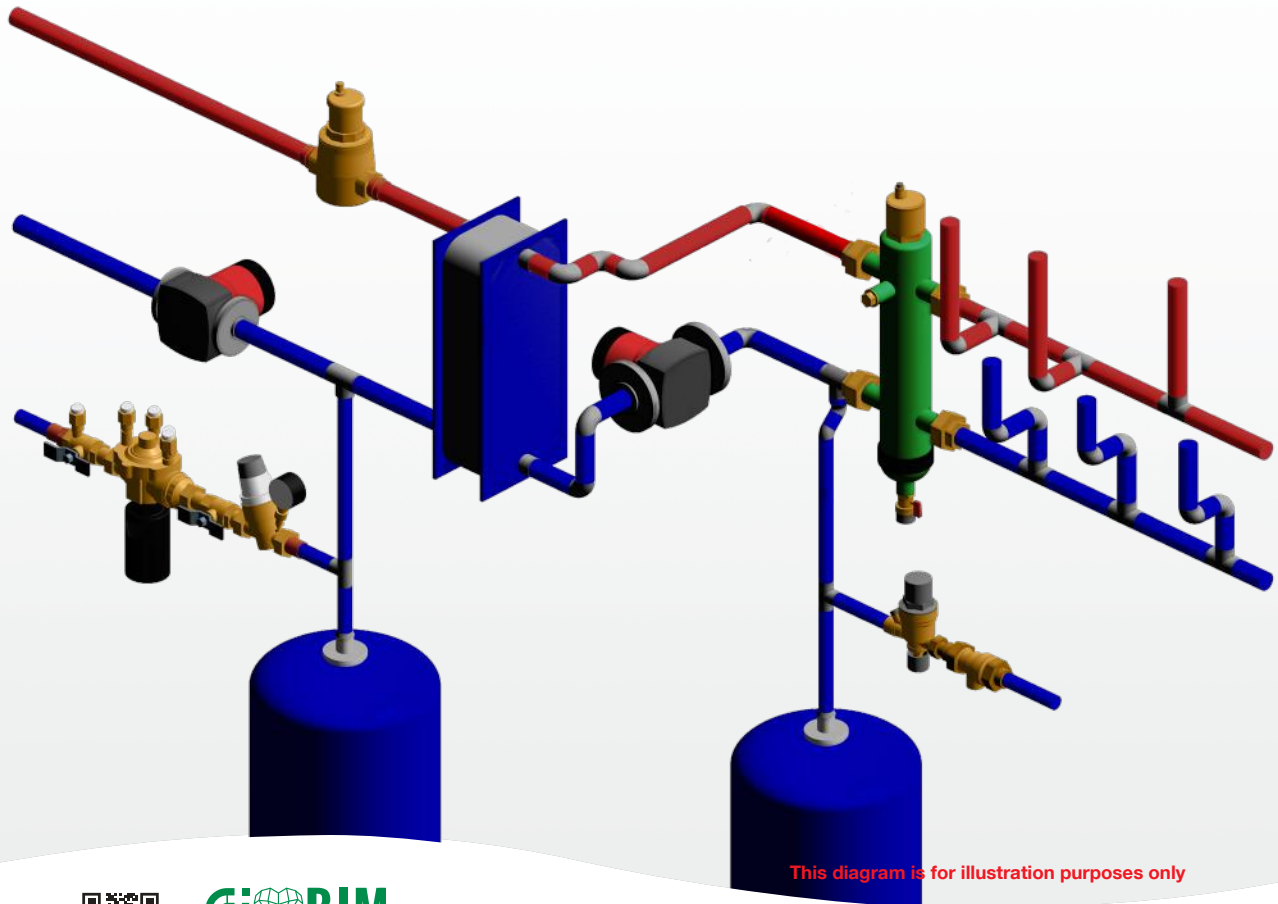

This diagram is for illustration purposes only



**BIM**  
bim.caleffi.com

### PRODUCTS INCLUDED IN SECTION

- Water treatment filling units
- Fill and Flush cart
- Automatic filling units
- Boiler trim kits

WATER TREATMENT FILLING UNITS



NA573

Replenishment water treatment filling unit, demineralizes site water through a color changing (indicates when to change) demineralizing cartridge.  
 Max. inlet pressure: 125.  
 Max. working temperature: 100°F.  
 Max. flow: 1 gpm.  
 TDS of water after treatment: < 30 ppm.

Code	Description	Lbs	USD
NA573022*	1/2" FNPT	7.4	417.00
NA573100**	Replacement filter housing assembly	3.4	190.00
NA573102	Replacement color-changing filter	1.0	96.80

\*Complete including back flow preventer, isolation valves, filter housing with resin cartridge and AutoFill™.  
 \*\*Filter housing only. Includes color changing demineralizing cartridge.

Function

The replenishment water treatment filling unit is an assembly consisting of a backflow preventer, isolation valves, filter housing unit with replaceable resin cartridge and AutoFill™ pre-adjustable fill valve. This unit is installed on the water inlet piping in sealed hydronic heating or cooling systems. Three important functions are provided in this single filling unit assembly: maintaining the pressure of the system stable at a set value and automatically filling up with water as required; protecting drinking water systems from return flow, caused by back-siphoning or back pressure of contaminated fluids; and producing from site-sourced water, demineralized water of an ideal grade for use in closed hydronic heating and cooling systems. Minerals causing hardness are almost entirely eliminated. This prevents premature equipment malfunction including reduced efficiency or component failure due to lime scale formation – a common affliction of heat exchangers. Demineralized water is low in electrical conductivity to minimize corrosion due to galvanic attack. Demineralized water eliminates the variability of mineral content found in untreated site water which provides more reliable dosing when chemical additives are used – such as glycol.

Construction detail

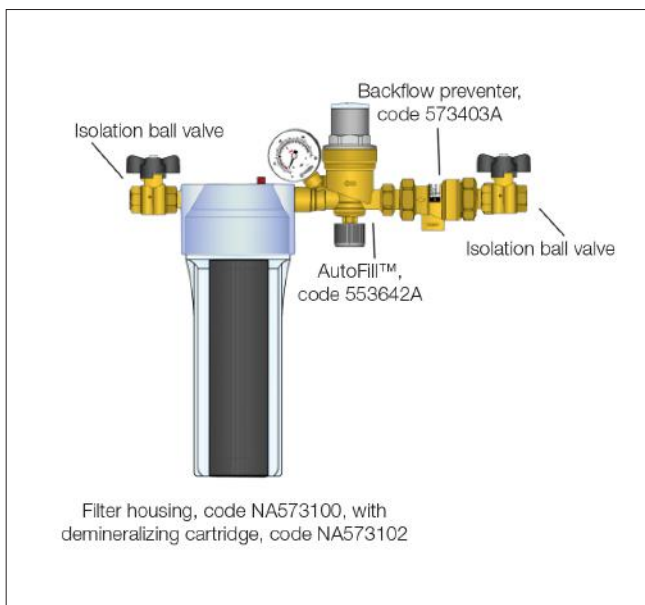

Installation

The replacement water treatment filling unit must be horizontally installed following the direction of flow as indicated by the arrow on the AutoFill™ or 573 backflow preventer body. The replacement water treatment filling unit is factory pre-assembled. Fittings may have loosened during shipping and handle. Check the fittings and tighten accordingly.

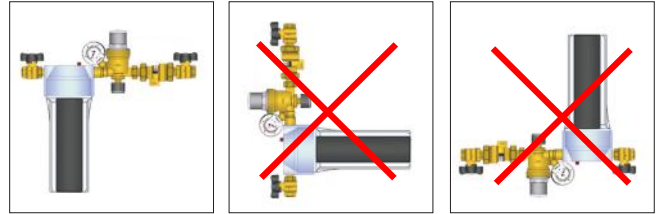

Cartridge change

1. Close the isolation ball valves. 2. Turn the cartridge with white plastic wrench included with unit. 3. Remove the used cartridge and discard them. 4. Insert the new cartridge. 5. Turn the cartridge and tighten in place with the white plastic wrench. 6. Re-open the isolation ball valves to return to normal operation.

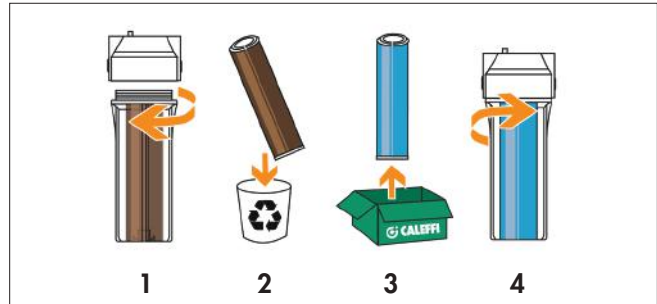

NA570 HYDROFILL™ replacement twist-on lid.

Code	Description	Lbs	USD
NA57094	Replacement twist-on lid	3.0	686.00

NA570 HYDROFILL™ replacement parts.



Code	Description	Lbs	USD
NA57092	Replacement internal inlet/outlet screens	1.5	62.70
NA57093	Replacement o-ring seal kit	0.1	101.00



Resin bags for NA570 HYDROFILL™ in reusable plastic pail.

Code	Description	Lbs	USD
NA570971	Two resin bags for NA570912	22	504.00
NA570974	Four resin bags for NA570924	43	1,008.00



**FILL AND FLUSH CART**



**NA255  
HYDROFLUSH™**

The fill and flush pump cart is portable, leak-tested for a safe, quick and clean way to fill and flush solar, geo thermal and hydronic systems.

- Medium: water, glycol and cleaning fluids.
- Tank: 10 gallon with dirt filter.
- Max. tank medium temperature: 140°F.
- Pump delivery flow: 1–15 gpm.
- Pump feet of head: 125
- Max. pump pressure: 55 psi.
- Pump power: ½ HP (120 V AC).
- Isolating ball valves: ¾" garden hose thread.
- Transfer hoses: 8' with ¾" GHT (2 ea).
- Dimensions: 48"H x 20"W x 18"D.

**Function**

The fill and flush pump cart is portable and leak-tested for a safe, quick and clean way to fill and flush solar, geothermal and hydronic systems.

Connect the fill/purge valves to the fill and flush system, allow fluid to circulate and remove air and dirt in system.

Code	Description	Lbs	USD
<b>NA25510</b>	Clean, fill and flush cart	60	<b>3,489.00</b>
<b>NA11338</b>	Replacement hose, ¾" ID, FxF GHT	3.0	<b>65.00</b>

**Dimensions:**

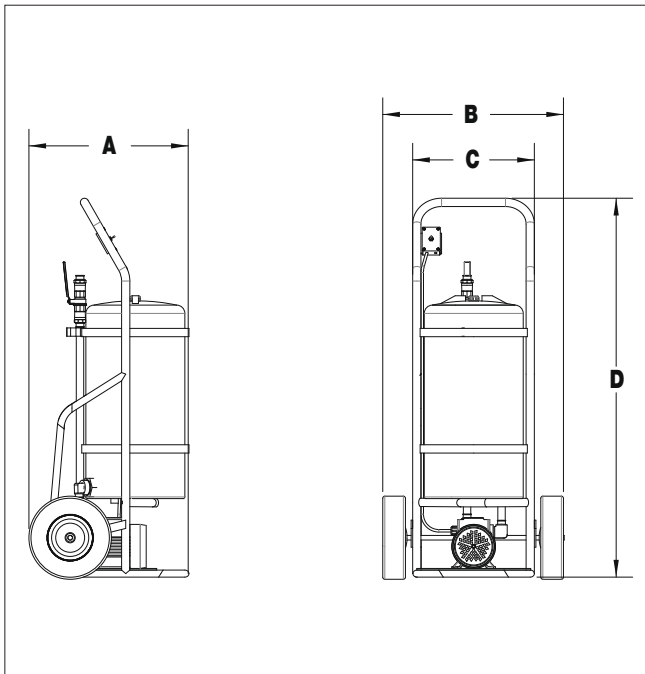

Code	A	B	C	D	Weight	Capacity
NA25510	19 ½"	20 "	14"	46 ¼"	85 lbs	10 gallon

**Radiant**

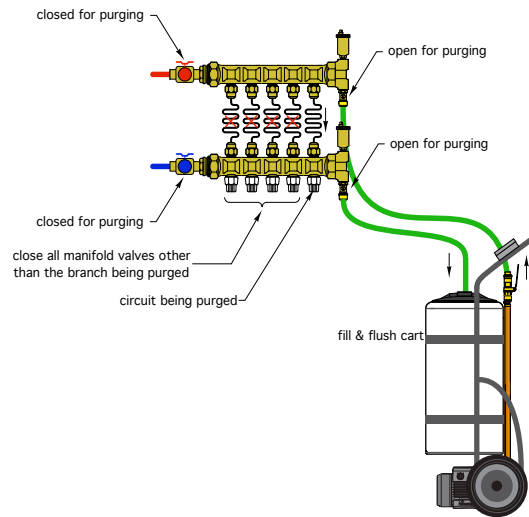

**Hydronic**

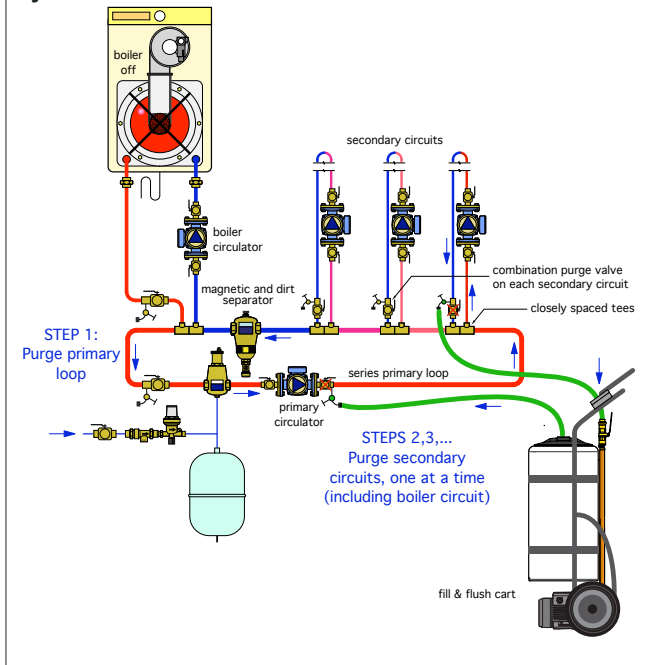

**AUTOMATIC FILLING UNITS**



**553 AutoFill™**

Pre-adjustable automatic filling valve, anti-scale, visual system pressure indicator. Complete with manual shut-off valve, strainer and check valve. Brass body.  
 Max. inlet pressure: 230 psi.  
 Max. working temperature: 150°F.  
 Setting pressure range: 3–60 psi.  
 Preset outlet pressure: 15 psi.  
 Pressure gauge scale: 0–60 psi / 0–4 bar.

Code	Description	Lbs	USD
553549A	½" sweat union in, ½" FNPT out	1.7	<b>119.00</b>
553649A*	½" sweat union in, ½" FNPT out	1.7	<b>134.00</b>
553542A	½" NPT male union in, ½" FNPT out	1.7	<b>127.00</b>
553642A*	½" NPT male union in, ½" FNPT out	1.7	<b>142.00</b>

\*With pressure gauge.



**573 AutoFill™ Combo**

Pre-adjustable automatic filling valve with backflow preventer. Brass body.  
 Max. inlet pressure: 175 psi.  
 Max. working temperature: 150°F.  
 Setting pressure range: 3–60 psi.  
 Preset outlet pressure: 15 psi.  
 Pressure gauge scale: 0–60 psi / 0–4 bar.

Code	Description	Lbs	USD
573002A	½" NPT female union in, ½" FNPT out	5.0	<b>214.00</b>
573012A*	½" NPT female union in, ½" FNPT out	5.0	<b>231.00</b>
573006A	½" press union in, ½" press out	5.0	<b>239.00</b>
573016A*	½" press union in, ½" press out	5.0	<b>258.00</b>
573007A	½" press union in, ½" FNPT out	5.0	<b>228.00</b>
573017A*	½" press union in, ½" FNPT out	5.0	<b>245.00</b>
573009A	½" sweat union in, ½" FNPT out	5.0	<b>204.00</b>
573019A*	½" sweat union in, ½" FNPT out	5.0	<b>221.00</b>

\*With pressure gauge.



**574 AutoFill™ Combo**

Pre-adjustable automatic filling valve with testable reduced pressure zone backflow preventer. Brass body.  
 Max. working pressure: 150 psi.  
 Max. working temperature: 150°F.  
 Setting pressure range: 3–60 psi.  
 Preset outlet pressure: 15 psi.  
 Pressure gauge scale: 0–60 psi / 0–4 bar.

Code	Description	Lbs	USD
574002A	½" FNPT	9.4	<b>474.00</b>
574012A	½" FNPT, gauge	9.4	<b>487.00</b>
574206A	½" press	9.4	<b>495.00</b>
574216A	½" press, gauge	9.4	<b>484.00</b>
574207A	½" press in x FNPT out	9.4	<b>460.00</b>
574217A	½" press in x FNPT out, gauge	9.4	<b>499.00</b>



Code	Description	Lbs	USD
NA10363	0-60 psi/0-4 bar, ¼" NPT	0.1	<b>15.60</b>



Code	Description	Lbs	USD
F59650	553 AutoFill™ replacement cartridge	0.2	<b>35.40</b>



Code	Description	Lbs	USD
NA10197	AutoFill™ clear plastic disc cover	0.1	<b>1.60</b>

**Application Diagram**

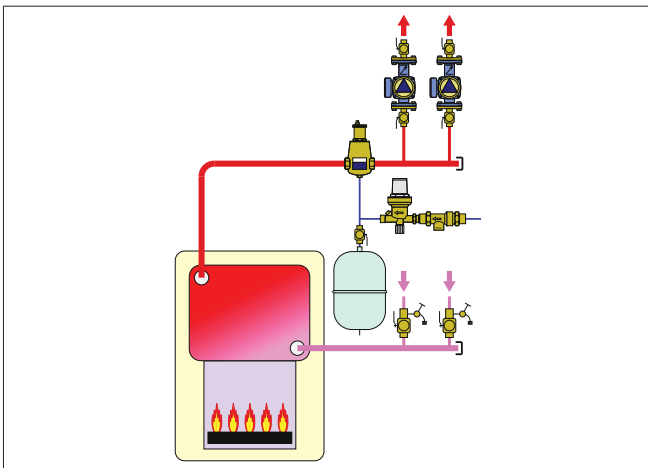

**Construction**

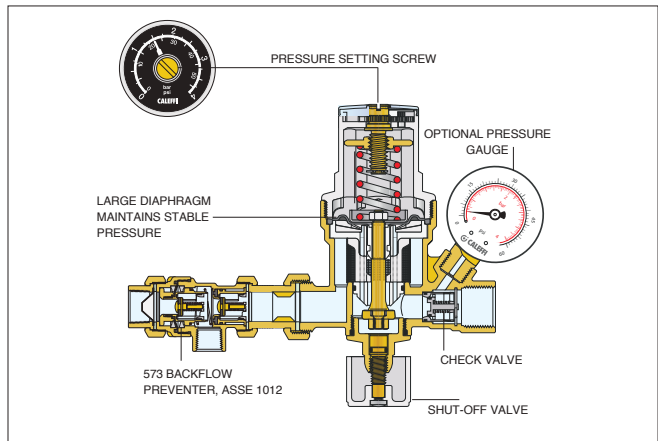

**COMMERCIAL AUTOMATIC FILLING UNITS**



**5350 AutoFill™**

Automatic filling valve. Complete with integral downstream pressure gauge and pressure setting adjustment knob. Max. working pressure: 365 psi. Max. working temperature: 140°F. Pressure gauge scale: 0–100 psi / 0–7 bar. Pressure setting range: 6–90 psi. Preset outlet pressure: 15 psi.

Code	Description	Lbs	USD
535059A	¾" sweat union	2.3	153.00
535069A	1" sweat union	2.4	164.00
535051A	¾" NPT male union	2.3	157.00
535061A	1" NPT male union	2.4	165.00
535056A	¾" press union	2.3	160.00
535066A	1" press union	2.4	173.00
535057A	¾" PEX crimp union	2.3	153.00
535067A	1" PEX crimp union	2.4	166.00
535058A	¾" PEX expansion union	2.3	153.00
535068A	1" PEX expansion union	2.4	166.00



**5350 AutoFill™ Body**

Automatic filling valve. Brass body. Complete with integral downstream pressure gauge and pressure setting adjustment knob. See fitting selection table in Section 8.

Code	Description	Lbs	USD
535951A	AutoFill™ body, no fittings	2.0	109.00



**574 AutoFill™ Combo**

Pre-adjustable automatic filling valve with testable reduced pressure zone backflow preventer. Max. working pressure: 150 psi. Max. working temperature: 140°F. Pressure gauge scale: 0–100 psi / 0–7 bar. Pressure setting range: 6–90 psi. Preset outlet pressure: 15 psi.

Code	Description	Lbs	USD
574151A	¾" FNPT in, ¾" NPT male union out	9.4	578.00
574161A	1" FNPT in, 1" NPT male union out	9.4	579.00
574156A	¾" press	9.4	614.00
574166A	1" press	9.4	633.00
574157A	¾" press in, ¾" NPT male union out	9.4	596.00
574167A	1" press in, 1" NPT male union out	9.4	626.00



**NA102**

Pressure gauge fits 5350 Series AutoFill™. Dial size: 2". Pressure range: 0–100 psi / 0–7 bar. Connection: 1/8" NPT.

Code	Description	Lbs	USD
NA10273	0-100 psi / 0-7 bar, 1/8" MNPT	0.2	14.60



Replacement cartridge for 5350 Series AutoFill™.

Code	Description	Lbs	USD
535004	AutoFill™ 5350 Series replacement cartridge	0.2	56.40

**BOILER TRIM KITS**



**NA553**

Boiler Trim Kits. 6 configurations combining 8 boiler installation components in one box. This kit includes:

- (1) Caleffi DISCAL® air separator
- (1) Dual check backflow preventer: ½" NPT, sweat or press union
- (1) AutoFill™
- (1) Expansion tank check valve
- (2) Brass nipples: 3"
- (1) NPT brass tee
- (1) Expansion tank

Code	Description	Tank size (gal)	Lbs	USD
NA553369	1" sweat	4.4	15	578.00
NA553379	1¼" sweat	4.4	16	671.00
NA553362	1" FNPT	4.4	15	591.00
NA553372	1¼" FNPT	4.4	16	685.00
NA553366	1" press	4.4	15	633.00
NA553376	1¼" press	4.4	16	761.00



**NA553**

Boiler Trim Kits. 6 configurations combining 8 boiler installation components in one box. This kit includes:

- (1) Caleffi DISCAL® air separator
- (1) RPZ backflow preventer
- (1) AutoFill™
- (1) Expansion tank check valve
- (2) Brass nipples: 3"
- (1) NPT brass tee
- (1) Expansion tank

Code	Description	Tank size (gal)	Lbs	USD
NA553369R	1" sweat	4.4	19	930.00
NA553379R	1¼" sweat	4.4	20	1,021.00
NA553362R	1" FNPT	4.4	19	940.00
NA553372R	1¼" FNPT	4.4	20	1,036.00
NA553366R	1" press	4.4	19	985.00
NA553376R	1¼" press	4.4	20	1,114.00

# FAST CONNECTIONS EASY & VERSATILE



**Fast, leak-proof and no-flame** Press and PEX connections are becoming the preferred standard by many professionals. Caleffi offers these convenient connections on our most popular products. Dual union valve bodies allow for flexible **mixing or matching of inlet and outlet fitting choices** to save transition adapters. **CALEFFI GUARANTEED.**



# FITTINGS AND MISCELLANEOUS COMPONENTS

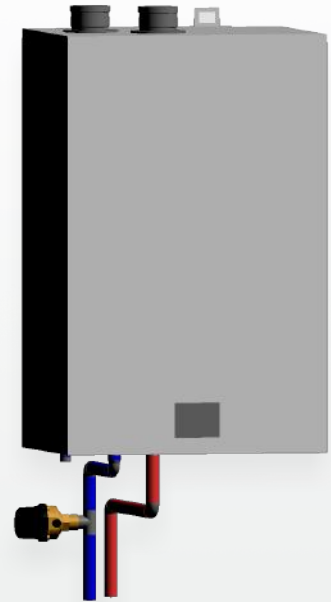
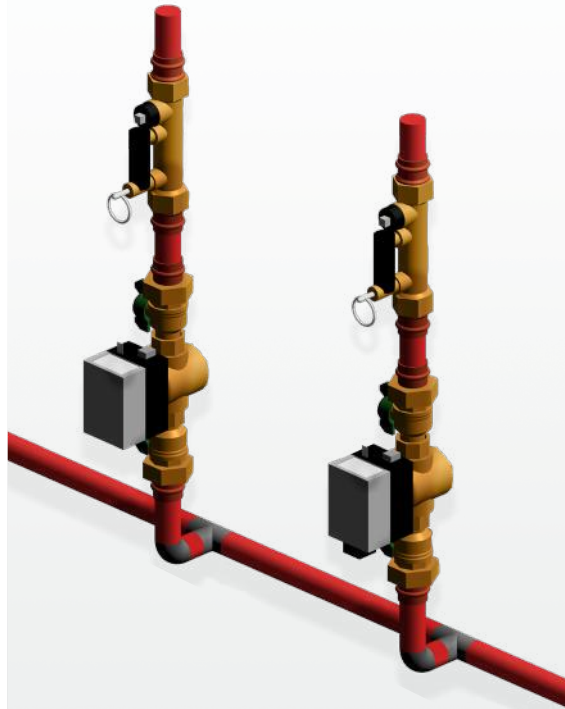
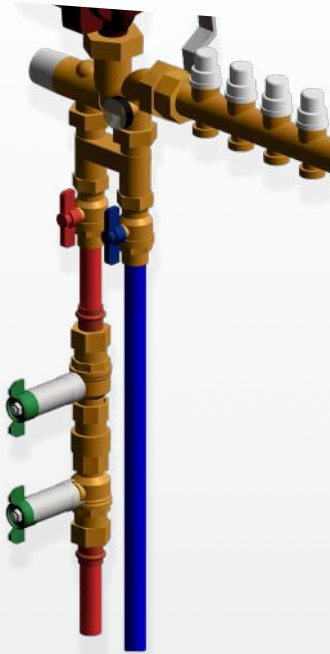

This diagram is for illustration purposes only



  
bim.caleffi.com

## PRODUCTS INCLUDED IN SECTION

- Fittings configuration table
- Small mixing valves, zone valves, others with 1" union fittings
- PresCal™ pressure reducing valve fittings
- Press fitting kits
- Mixing valve fittings
- AutoFill™ and backflow preventer fittings
- Hydro separator fittings
- Fittings with threads
- Differential pressure bypass
- Uni-Switch™ Universal flow switch
- Miscellaneous components

## FITTING CONFIGURATION TABLE

Product Series	Code	Description	Nut code	Tailpiece code	Washer code	USD
535H PresCal™ (½") 533H PresCal™ (½") 553 AutoFill™	NA20543	½" FNPT, ¾" nut, washer	incl. w/tail	F49644	incl. w/tail	<b>20.90</b>
	NA20540	½" MNPT, ¾" nut, washer	F41186	F31868	R0001458	<b>17.30</b>
	NA20549	½" sweat, ¾" nut, washer	incl. w/tail	F49655	incl. w/tail	<b>15.10</b>
	NA20546	½" press, ¾" nut, washer	F41186	NA10809	R0001458	<b>17.70</b>
127 FlowCal™	NA20643	½" FNPT, 1" nut, washer	F0000698	NA10569	R20011	<b>20.90</b>
	NA20640	½" MNPT, 1" nut, washer	F61008	R31981	R20011	<b>18.00</b>
	NA20640C	½" MNPT, 1" nut, washer, check	F61008	59893A	R20011	<b>28.10</b>
	NA20649	½" sweat, 1" nut, washer	F61008	NA10002	R20011	<b>14.90</b>
	NA20649C	½" sweat, 1" nut, washer, check	F61008	NA10164	R20011	<b>25.10</b>
	NA20646	½" press, 1" nut, washer	F61008	NA10403	R20011	<b>19.30</b>
	NA20646C	½" press, 1" nut, washer, check	F61008	NA10869C	R20011	<b>20.70</b>
	NA20647	½" PEX crimp, 1" nut, washer	F61008	F0000492	R20011	<b>14.90</b>
	NA20647C	½" PEX crimp, 1" nut, washer, check	F61008	NA10484	R20011	<b>25.10</b>
	NA20648	½" PEX expansion, 1" nut, washer	F61008	F0001007	R20011	<b>14.90</b>
520 TankMixer™	NA20648C	½" PEX expansion, 1" nut, washer, check	F61008	NA10634	R20011	<b>25.10</b>
	NA20653	¾" FNPT, 1" nut, washer	incl. w/tail	F49645	incl. w/tail	<b>23.80</b>
521 MixCal™	NA20650	¾" MNPT, 1" nut, washer	F61008	31901A	R20011	<b>20.90</b>
	NA20650C	¾" MNPT, 1" nut, washer, check	F61008	59840A	R20011	<b>35.90</b>
5213 TMV (req. inlet port check)	NA20659	¾" sweat, 1" nut, washer	F61008	NA10003	R20011	<b>17.90</b>
5350 AutoFill™	NA20659C	¾" sweat, 1" nut, washer, check	F61008	NA10165	R20011	<b>32.90</b>
533H PresCal™ (¾")	NA20656	¾" press, 1" nut, washer	incl. w/tail	NA16265	R20011	<b>21.00</b>
535H PresCal™ (¾")	NA20656C	¾" press, 1" nut, washer, check	incl. w/tail	NA16265LC	R20011	<b>46.70</b>
5517 DISCAL®	NA20657	¾" PEX crimp, 1" nut, washer	F61008	F0000520	R20011	<b>17.90</b>
	NA20657C	¾" PEX crimp, 1" nut, washer, check	F61008	NA10485	R20011	<b>32.90</b>
6000 LEGIOMIX (¾")	NA20658	¾" PEX expansion, 1" nut, washer	F61008	F0001008	R20011	<b>17.90</b>
644 Ball Valve	NA20658C	¾" PEX expansion, 1" nut, washer, check	F61008	NA10635	R20011	<b>32.90</b>
676 Zone Valve	NA20660	1" MNPT, 1" nut, washer	incl. w/tail	59817A	R20011	<b>34.60</b>
	NA20660C	1" MNPT, 1" nut, washer, check	incl. w/tail	59894A	R20011	<b>49.60</b>
Z2, Z3 Zone Valve	NA20669	1" sweat, 1" nut, washer	incl. w/tail	59834A	R20011	<b>31.20</b>
NA512xx Serviceable check	NA20669C	1" sweat, 1" nut, washer, check	incl. w/tail	59906A	R20011	<b>46.20</b>
	NA20666	1" press, 1" nut, washer	incl. w/tail	NA16266	R20011	<b>36.40</b>
V40 Flow Meter	NA20666C	1" press, 1" nut, washer, check	incl. w/tail	NA16266LC	R20011	<b>71.40</b>
	NA20667	1" PEX crimp, 1" nut, washer	F61008	F0000521	R20011	<b>31.20</b>
	NA20667C	1" PEX crimp, 1" nut, washer, check	F61008	NA10486	R20011	<b>46.20</b>
	NA20668	1" PEX expansion, 1" nut, washer	F000698	F0001009	R20011	<b>31.20</b>
	NA20668C	1" PEX expansion, 1" nut, washer, check	F000698	NA10636	R20011	<b>46.20</b>
535H PresCal™ (1")	NA20760	1" MNPT, 1¼" nut, washer	R31495	NA10116	R0001454	<b>30.30</b>
	NA20763	1" FNPT, 1¼" nut, washer	incl. w/tail	F49646	incl. w/tail	<b>33.30</b>
	NA20767	1" PEX crimp, 1¼" nut, washer	R31495	NA10496	R0001454	<b>31.90</b>
	NA20768	1" PEX expansion, 1¼" nut, washer	R31495	NA10556	R0001454	<b>31.20</b>
	NA20766	1" press, 1¼" nut, washer	R11222	NA10747	R0001454	<b>40.20</b>
520 AngleMix™ (1")	NA20769	1" sweat, 1¼" nut, washer	incl. w/tail	F49657	incl. w/tail	<b>24.60</b>
	NA20873	1¼" FNPT, 1½" nut, washer	incl. w/tail	F49647	incl. w/tail	<b>60.60</b>
535H PresCal™ (1¼")	NA20879	1¼" sweat, 1½" nut, washer	R31589	41787 CST	R0001457	<b>54.60</b>
	NA513xx Serviceable check	NA20876	1¼" press, 1½" nut, washer	R11221	NA10707	R0001457
535H PresCal™ (1½")	NA20983	1½" FNPT, 2" nut, washer	incl. w/tail	F0000493	incl. w/tail	<b>92.00</b>
	NA20989	1½" sweat, 2" nut, washer	incl. w/tail	F0000494	incl. w/tail	<b>76.50</b>
	NA20986	1½" press, 2" nut, washer	incl. w/tail	NA10715	R0001459	<b>167.00</b>

**FITTING CONFIGURATION TABLE**

Product Series	Code	Description	Nut code	Tailpiece code	Washer code	USD
535H PresCal™ (2")	NA21193	2" FNPT, 2½" nut, washer	incl. w/tail	F0000495	R0001460	<b>128.00</b>
	NA21199	2" sweat, 2½" nut, washer	incl. w/tail	F0000496	incl. w/tail	<b>139.00</b>
NA514xx Serviceable check	NA21196	2" press, 2½" nut, washer	incl. w/tail	NA10709	R0001460	<b>233.00</b>
548, 5495 Seps (1")	NA20863	1" FNPT, 1½" nut, washer	R0001452	31553 FD	R50005	<b>37.30</b>
	NA20869	1" sweat, 1½" nut, washer	R0001452	31554 FD	R50005	<b>37.70</b>
	NA20866	1" press 1½" nut, washer	R0001452	NA10406	R50005	<b>61.90</b>
548, 5495 Seps (1¼")	NA20973	1¼" FNPT, 2" nut, washer	R53003	31401 FD	R50008	<b>79.40</b>
	NA20979	1¼" sweat, 2" nut, washer	R53003	31403 FD	R50008	<b>106.00</b>
	NA20976	1¼" press 2" nut, washer	R53003	NA10407	R50008	<b>109.00</b>
548, 5495 Seps (1½")	NA21083	1½" FNPT, 2¼" nut, washer	R53004	R41441	R50047	<b>86.50</b>
	NA21089	1½" sweat, 2¼" nut, washer	R53004	41882A	R50047	<b>110.00</b>
5461 DISCALDIRTMAG™ (1½")	NA21086	1½" press 2¼" nut, washer	R53004	NA10408	R50047	<b>145.00</b>
548, 5495 Seps (2")	NA21293	2" FNPT, 2¾" nut, washer	R53005	31426 FD	R50048	<b>133.00</b>
	NA21299	2" sweat, 2¾" nut, washer	R53005	31428 FD	R50048	<b>157.00</b>
5461 DISCALDIRTMAG™ (2")	NA21296	2" press 2¾" nut, washer	R53005	NA10409	R50048	<b>214.00</b>
5231 MixCal+™ (1") 6000 LEGIOMIX® (1")	NA20860	1" MNPT 1½" nut, washer	R31589	NA10009	R0001457	<b>41.50</b>
	NA20869	1" sweat, 1½" nut, washer	R31589	31554 FD	R0001457	<b>37.70</b>
	NA20866	1" press, 1-½" nut, washer	R31589	NA10706	R0001457	<b>61.90</b>
5231 MixCal+™ (1¼") 6000 LEGIOMIX® (1¼")	NA20870	1¼" MNPT 1½" nut, washer	R31589	R41660	R0001457	<b>72.90</b>
	NA20879	1¼" sweat, 1½" nut, washer	R31589	41787 CST	R0001457	<b>54.60</b>
	NA20876	1-¼" press, 1-½" nut, washer	R11221	NA10707	R0001457	<b>80.00</b>
5231 MixCal+™ (1½") 6000 LEGIOMIX® (1½")	NA21180	1½" MNPT 2½" nut, washer	R51838	41371A	R0001460	<b>123.00</b>
	NA21189	1½" sweat 2½" nut, washer	R51838	41788 CST	R0001460	<b>107.00</b>
	NA21186	1½" press, 2-½" nut, washer	R51838	NA10708	R0001460	<b>161.00</b>
5231 MixCal+™ (2") 6000 LEGIOMIX® (2")	NA21190	2" MNPT 2½" nut, washer	R51838	41372A	R0001460	<b>153.00</b>
	NA21199	2" sweat 2½" nut, washer	R51838	41789 CST	R0001460	<b>139.00</b>
	NA21196	2" press, 2-½" nut, washer	incl. w/tail	NA10709	R0001460	<b>233.00</b>

**SMALL MIXING VALVES, ZONE VALVES, OTHERS WITH 1" UNION FITTINGS**



Tail piece with check valve.  
Low lead brass.

Code	Description	Lbs	USD
<b>59893A</b>	½" NPT male fits 1" nut	0.2	<b>21.80</b>
<b>59840A</b>	¾" NPT male fits 1" nut	0.3	<b>29.80</b>



Tail piece without check valve.  
Low lead brass.

Code	Description	Lbs	USD
<b>R31981</b>	½" NPT male fits 1" nut	0.3	<b>11.60</b>
<b>31901A</b>	¾" NPT male fits 1" nut	0.4	<b>15.10</b>



Tail piece.  
Low lead brass. Requires sealing washer R20011, not included.

Code	Description	Lbs	USD
<b>59817A</b>	1" NPT male with 1" nut	0.4	<b>32.90</b>
<b>59894A</b>	1" NPT male with 1" nut w/check valve	0.5	<b>47.80</b>



Tail piece with check valve.  
Low lead brass.

Code	Description	Lbs	USD
<b>59904A</b>	½" sweat fits 1" nut	0.2	<b>19.00</b>
<b>59905A</b>	¾" sweat for 1" nut	0.3	<b>26.60</b>



Copper press tail piece with 1" brass union nut. Low lead. Requires sealing washer, not included.

Code	Description	Lbs	USD
<b>NA16264</b>	½" press with 1" union nut	0.3	<b>17.60</b>
<b>NA16265</b>	¾" press with 1" union nut	0.4	<b>19.40</b>
<b>NA16266</b>	1" press with 1" union nut	0.5	<b>34.50</b>



Long copper press tail piece with 1" brass union slip nut. Low lead. Requires sealing washer, not included.

Code	Description	Lbs	USD
<b>NA10864L</b>	½" press with 1" union nut <b>NEW</b>	0.3	<b>17.10</b>
<b>NA10864LC</b>	½" press with 1" union nut/check valve <b>NEW</b>	0.3	<b>23.00</b>
<b>NA16265L</b>	¾" long press with 1" union slip nut	0.3	<b>44.40</b>
<b>NA16265LC</b>	¾" long press with 1" union nut/check valve	0.3	<b>56.20</b>
<b>NA16266L</b>	1" long press with 1" union slip nut	0.3	<b>66.30</b>
<b>NA16266LC</b>	1" long press with 1" union nut/check valve	0.3	<b>68.90</b>



Washer fits 1" union thread.

Code	Description	Lbs	USD
<b>R20011</b>	1" union washer	0.1	<b>1.60</b>



Tail piece.  
Low lead brass.

Code	Description	Lbs	USD
<b>NA10002</b>	½" sweat fits 1" nut	0.2	<b>8.40</b>
<b>NA10003</b>	¾" sweat fits 1" nut	0.3	<b>11.60</b>



Tail piece.  
Low lead brass. Requires sealing washer R20011, not included.

Code	Description	Lbs	USD
<b>59834A</b>	1" sweat with 1" nut	0.4	<b>29.70</b>
<b>59906A</b>	1" sweat with 1" nut w/check valve	0.5	<b>44.70</b>



Tail piece with high temperature check valve.  
Low lead brass.

Code	Description	Lbs	USD
<b>NA10164</b>	½" sweat fits 1" nut	0.2	<b>26.30</b>
<b>NA10165</b>	¾" sweat fits 1" nut	0.3	<b>30.70</b>



Tail piece with high temperature check valve.  
Low lead brass. Requires sealing washer R20011, not included.

Code	Description	Lbs	USD
<b>NA10166</b>	1" sweat with 1" nut w/check valve	0.4	<b>50.30</b>



Copper press low lead tail piece with check valve, requires F0000698 1" slip nut.

Code	Description	Lbs	USD
<b>NA10419C</b>	¾" press long fits 1" slip nut w/check	0.3	<b>45.00</b>



Copper press low lead tail piece, requires F0000698 1" slip nut.

Code	Description	Lbs	USD
<b>NA10403</b>	½" press fits 1" nut	0.1	<b>22.90</b>
<b>NA10864</b>	½" press long fits 1" nut <b>NEW</b>	0.1	<b>21.70</b>
<b>NA10744</b>	¾" press fits 1" slip nut <b>NEW</b>	0.1	<b>16.50</b>
<b>NA10419</b>	¾" press long fits 1" slip nut	0.3	<b>38.40</b>
<b>NA10404</b>	1" press fits 1" slip nut	0.4	<b>34.60</b>
<b>NA10786</b>	1" press long fits 1" slip nut	0.5	<b>58.40</b>



**SMALL MIXING VALVES, ZONE VALVES, OTHERS WITH 1" UNION FITTINGS**



Union nut fits 1" union thread.

Code	Description	Lbs	USD
<b>F61008</b>	1" brass nut	0.2	<b>4.60</b>
<b>F0000698</b>	1" brass slip nut	0.2	<b>6.40</b>



Compression fitting.

Code	Description	Lbs	USD
<b>F0000718</b>	3/8" compression tailpiece for 1" nut	0.1	<b>17.10</b>



PEX crimp (ASTM F1807) tailpiece for 1" union nut, requires sealing washer and nut, not included.

Code	Description	Lbs	USD
<b>F0000492</b>	1/2" PEX for 1" union nut	0.1	<b>8.40</b>
<b>F0000520</b>	3/4" PEX for 1" union nut	0.1	<b>11.60</b>
<b>F0000521</b>	1" PEX for 1" union nut	0.1	<b>24.90</b>



PEX expansion (ASTM F1960) tailpiece for 1" union nut, requires sealing washer and nut, not included.

Code	Description	Lbs	USD
<b>F0001007</b>	1/2" PEX for 1" union nut	0.1	<b>8.40</b>
<b>F0001008</b>	3/4" PEX for 1" union nut	0.1	<b>11.60</b>
<b>F0001009</b>	1" PEX for 1" union nut	0.1	<b>24.90</b>



PEX crimp (ASTM F1807) tailpiece for 1" union nut with check valve, requires sealing washer and nut, not included.

Code	Description	Lbs	USD
<b>NA10484</b>	1/2" PEX for 1" union nut	0.1	<b>19.00</b>
<b>NA10485</b>	3/4" PEX for 1" union nut	0.1	<b>26.60</b>
<b>NA10486</b>	1" PEX for 1" union nut	0.1	<b>39.90</b>



PEX expansion (ASTM F1960) tailpiece for 1" union nut with check valve, requires sealing washer and nut, not included.

Code	Description	Lbs	USD
<b>NA10634</b>	1/2" PEX for 1" union nut	0.1	<b>19.00</b>
<b>NA10635</b>	3/4" PEX for 1" union nut	0.1	<b>26.60</b>
<b>NA10636</b>	1" PEX for 1" union nut	0.1	<b>39.90</b>

**5231 AND 6000 SERIES MIXING VALVE FITTINGS**



Press tail piece.  
Low lead brass.

Code	Description	Lbs	USD
<b>NA10809</b>	1/2" press tailpiece for 3/4" nut <b>NEW</b>	0.2	<b>16.50</b>
<b>NA10744</b>	3/4" press tailpiece for 1" nut <b>NEW</b>	0.2	<b>16.50</b>
<b>NA10747</b>	1" press tailpiece for 1 1/4" slip nut <b>NEW</b>	0.4	<b>22.80</b>
<b>NA10707</b>	1 1/4" press tailpiece for 1 1/2" nut	0.4	<b>84.20</b>
<b>NA10708</b>	1 1/2" press tailpiece with 2" nut	0.5	<b>121.00</b>
<b>NA10709</b>	2" press tailpiece with 2 1/2" nut	0.5	<b>214.00</b>



Sweat tail piece.  
Low lead brass.

Code	Description	Lbs	USD
<b>31554 FD</b>	1" sweat	0.3	<b>36.50</b>
<b>41787 CST</b>	1 1/4" sweat	0.3	<b>35.80</b>
<b>41788 CST</b>	1 1/2" sweat	0.4	<b>56.80</b>
<b>41789 CST</b>	2" sweat	0.5	<b>73.90</b>



NPT male tailpiece.  
Low lead brass.

Code	Description	Lbs	USD
<b>NA10009</b>	1" NPT male	0.3	<b>45.80</b>
<b>R41660</b>	1 1/4" NPT male	0.3	<b>52.40</b>
<b>41371A</b>	1 1/2" NPT male	0.4	<b>59.10</b>
<b>41372A</b>	2" NPT male	0.5	<b>76.50</b>



Union nut.

Code	Description	Lbs	USD
<b>F61008</b>	1" brass nut	0.2	<b>4.60</b>
<b>F0000698*</b>	1" brass slip nut	0.2	<b>6.40</b>
<b>R31589**</b>	1 1/2" union nut	0.2	<b>15.60</b>
<b>R11221</b>	1 1/2" slip union nut for 1-3/4" press	0.2	<b>15.20</b>
<b>R51838***</b>	2 1/2" union nut	0.3	<b>38.10</b>

\* Fits 3/4" valves  
\*\* Fits 1" and 1 1/4" valves  
\*\*\* Fits 1 1/2" and 2" valves



Washer.

Code	Description	Lbs	USD
<b>R0001462*</b>	1" union washer	0.1	<b>1.60</b>
<b>R0001457**</b>	1 1/2" union washer	0.1	<b>3.60</b>
<b>R0001460***</b>	2 1/2" union washer	0.1	<b>17.00</b>

\* Fits 3/4" valves  
\*\* Fits 1" and 1 1/4" valves  
\*\*\* Fits 1 1/2" and 2" valves

**PRESCAL™ PRESSURE REDUCING VALVE FITTINGS**



NPT female tailpieces with union nut and washer.

Code	Description	Lbs	USD
<b>F49644</b>	½" NPT female tailpiece with ¾" union nut	0.4	<b>20.30</b>
<b>F49645</b>	¾" NPT female tailpiece with 1" union nut	0.5	<b>23.00</b>
<b>F49646</b>	1" NPT female tailpiece with 1¼" union nut	0.6	<b>30.60</b>
<b>F49647</b>	1¼" NPT female tailpiece with 1½" union nut	0.7	<b>51.00</b>
<b>F0000493</b>	1½" NPT female tailpiece with 2" union nut	0.9	<b>91.70</b>
<b>F0000495</b>	2" NPT female tailpiece with 2½" union nut	1.0	<b>109.00</b>



PEX expansion tailpieces (ASTM F1960) for union nut.

Code	Description	Lbs	USD
<b>F0001008</b>	¾" PEX expansion tailpiece for 1" union nut	0.1	<b>11.60</b>
<b>NA10556</b>	1" PEX expansion tailpiece for 1¼" union nut	0.2	<b>15.20</b>



NPT male tailpieces for union nut.

Code	Description	Lbs	USD
<b>F31868</b>	½" NPT male tailpiece for ¾" union nut	0.1	<b>12.20</b>
<b>31901A</b>	¾" NPT male tailpiece for 1" union nut	0.1	<b>15.10</b>



PEX crimp tailpieces (ASTM F1807) for union nut.

Code	Description	Lbs	USD
<b>F0000520</b>	¾" PEX crimp tailpiece for 1" union nut	0.1	<b>11.60</b>
<b>NA10496</b>	1" PEX crimp tailpiece for 1¼" union nut	0.2	<b>27.10</b>



Sweat tailpieces.

Code	Description	Lbs	USD
<b>NA10001</b>	½" sweat tailpiece for ¾" union nut	0.1	<b>10.20</b>
<b>NA10003</b>	¾" sweat tailpiece for 1" union nut	0.2	<b>11.60</b>
<b>F49657*</b>	1" sweat tailpiece with 1¼" nut	0.4	<b>20.30</b>
<b>41787 CST</b>	1¼" sweat tailpiece for 1½" union nut	0.3	<b>35.80</b>
<b>F0000494*</b>	1½" sweat tailpiece with 2" union nut	0.7	<b>68.90</b>
<b>F0000496*</b>	2" sweat tailpiece with 2½" union nut	0.8	<b>94.30</b>

\*With washer



Union nut.

Code	Description	Lbs	USD
<b>F41186</b>	¾" union nut for ½" 535H	0.1	<b>3.80</b>
<b>F61008</b>	1" union nut for ¾" 535H	0.2	<b>4.60</b>
<b>R0000915</b>	1" slip union nut for ¾" 535H	0.2	<b>4.60</b>
<b>R31495</b>	1 ¼" union nut for 1" 535H	0.3	<b>7.60</b>
<b>R11222</b>	1 ¼" slip nut for 1" 535H	0.3	<b>7.60</b>
<b>R31589</b>	1 ½" union nut for 1-¼" 535H	0.4	<b>15.60</b>
<b>R53003</b>	2" union nut for 1-½" 535H	0.4	<b>31.00</b>
<b>R51838</b>	2 ½" union nut for 2" 535H	0.5	<b>38.10</b>



Press tailpieces.

Code	Description	Lbs	USD
<b>NA16265</b>	¾" press with 1" union nut	0.2	<b>19.40</b>
<b>NA10497</b>	1" press tailpiece with 1¼" union nut	0.4	<b>38.20</b>
<b>NA10707</b>	1¼" press tailpiece for 1½" union nut	0.6	<b>84.20</b>
<b>NA10715</b>	1½" press tailpiece with 2" union nut	0.8	<b>167.00</b>
<b>NA10709</b>	2" press tailpiece with 2½" union nut	0.9	<b>214.00</b>
<b>NA10744</b>	¾" press tailpiece for 1" nut <b>NEW</b>	0.2	<b>16.50</b>
<b>NA10747</b>	1" press tailpiece for 1¼" slip nut <b>NEW</b>	0.4	<b>22.80</b>
<b>NA10809</b>	½" press tailpiece for ¾" nut <b>NEW</b>	0.2	<b>16.50</b>



Union washers.

Code	Description	Lbs	USD
<b>R0001458</b>	¾" union washer for ½" 535H	0.1	<b>1.50</b>
<b>R20011</b>	1" union washer for ¾" 535H	0.1	<b>1.60</b>
<b>R0001454</b>	1-¼" union washer 1" 535H	0.1	<b>2.50</b>
<b>R0001457</b>	1½" union washer for 1¼" 535H	0.1	<b>3.60</b>
<b>R0001459</b>	2" union washer for 1½" 535H	0.1	<b>6.90</b>
<b>R0001460</b>	2½" union washer for 2" 535H	0.1	<b>17.00</b>

**AUTOFILL™ FITTINGS**



AutoFill™ union nut.

Code	Description	Lbs	USD
<b>F41186</b>	¾" union nut	0.1	<b>3.00</b>



AutoFill™ tail piece.

Code	Description	Lbs	USD
<b>NA10001</b>	½" sweat	0.3	<b>9.40</b>



AutoFill™ tail piece.

Code	Description	Lbs	USD
<b>F31868</b>	½" NPT male	0.1	<b>11.20</b>



AutoFill™ washer.

Code	Description	Lbs	USD
<b>R0001458</b>	¾" union washer	0.1	<b>1.40</b>

**BACKFLOW PREVENTER FITTINGS**



Tail piece with screen fits 573 backflow preventer.

Code	Description	Lbs	USD
<b>R0000892</b>	½" NPT female, outlet	0.1	<b>15.20</b>
<b>R0001393</b>	½" NPT female, inlet	0.1	<b>7.30</b>



Tail piece fits 573 backflow preventer.

Code	Description	Lbs	USD
<b>41380A</b>	½" sweat	0.1	<b>14.50</b>



Washer union fits 573 backflow preventer.

Code	Description	Lbs	USD
<b>R0001622</b>	Union washer	0.1	<b>3.50</b>

**SEPARATOR FITTINGS**



Tail piece for steel 548, 5495, 5461.

Code	Description	Lbs	USD
<b>31553 FD</b>	1" NPT female, fits 54...6A	0.3	<b>18.10</b>
<b>31401 FD</b>	1¼" NPT female, fits 54...7A	0.3	<b>39.20</b>
<b>R41441</b>	1½" NPT female, fits 54...8A	0.3	<b>39.60</b>
<b>31426 FD</b>	2" NPT female, fits 54...9A	0.4	<b>77.50</b>



Tail piece for steel 548, 5495, 5461.

Code	Description	Lbs	USD
<b>31554 FD</b>	1" sweat, fits 54...6A	0.3	<b>36.50</b>
<b>31403 FD</b>	1¼" sweat, fits 54...7A	0.3	<b>67.80</b>
<b>41882A</b>	1½" sweat, fits 54...8A	0.3	<b>64.20</b>
<b>31428 FD</b>	2" sweat, fits 54...9A	0.4	<b>105.00</b>



Press tail piece for steel 548, 5495, 5461.

Code	Description	Lbs	USD
<b>NA10707</b>	1¼" press tailpiece for 1½" nut	0.4	<b>1.40</b>
<b>NA10708</b>	1½" press tailpiece with 2" nut	0.5	<b>1.40</b>
<b>NA10709</b>	2" press tailpiece with 2½" nut	0.5	<b>1.40</b>



Union nut for steel 548, 5495, 5461.

Code	Description	Lbs	USD
<b>R0001452</b>	fits 54...6A	0.4	<b>15.10</b>
<b>R53003</b>	fits 54...7A	0.4	<b>31.00</b>
<b>R53004</b>	fits 54...8A	0.4	<b>31.00</b>
<b>R53005</b>	fits 54...9A	0.4	<b>35.50</b>



Union washer for steel 548, 5495, 5461.

Code	Description	Lbs	USD
<b>R50005</b>	fits 54...6A	0.2	<b>3.60</b>
<b>R50008</b>	fits 54...7A	0.2	<b>7.20</b>
<b>R50047</b>	fits 54...8A	0.2	<b>14.50</b>
<b>R50048</b>	fits 54...9A	0.2	<b>17.60</b>

**FITTINGS WITH 3/4" THREADS**



Union nut.

Code	Description	Lbs	USD
<b>F41186</b>	3/4" union nut	0.1	<b>3.00</b>

**FITTINGS WITH 1" THREADS**



Double nipple.

Code	Description	Lbs	USD
<b>NA12173</b>	1" NPT x 1" NPT	0.4	<b>27.40</b>



Sweat adapter.

Code	Description	Lbs	USD
<b>NA10062</b>	1" sweat adaptor w/ 1" male thread	0.1	<b>23.80</b>



Union nut fits 1" union thread.

Code	Description	Lbs	USD
<b>F61008</b>	1" brass nut	0.2	<b>4.60</b>
<b>F0000698</b>	1" brass slip nut	0.2	<b>6.40</b>



Nipple.

Code	Description	Lbs	USD
<b>NA12162</b>	3/4" male w/ O-ring x 1" male thread	0.2	<b>25.30</b>



Nipple.

Code	Description	Lbs	USD
<b>NA10064</b>	1" NPT w/ 1" male thread	0.2	<b>24.70</b>

**FITTINGS WITH 1 1/4" THREADS**



Sweat adapter.

Code	Description	Lbs	USD
<b>NA10119</b>	1" sweat adapter x 1 1/4" union thread	0.4	<b>30.20</b>



Bushing.

Code	Description	Lbs	USD
<b>NA10087</b>	1" female x 1 1/4" male thread bushing	0.4	<b>22.10</b>



Bushing.

Code	Description	Lbs	USD
<b>61215A</b>	1" NPT F x 1 1/4" M thread bushing	0.8	<b>22.00</b>



Nipple.

Code	Description	Lbs	USD
<b>R31706</b>	1" male x 1 1/4" male nipple	0.3	<b>27.40</b>



Union nut.

Code	Description	Lbs	USD
<b>R31495</b>	1 1/4" union nut	0.1	<b>7.60</b>



Washer.

Code	Description	Lbs	USD
<b>R0001454</b>	1 1/4" washer	0.1	<b>2.50</b>

**DIFFERENTIAL PRESSURE BYPASS**



**519**

Differential pressure by-pass valve. Adjustable from 2 to 10 psid. Brass body. Max. working pressure: 150 psi. Working temperature range: 32° – 230°F. ¾" flow up to 9 gpm. 1" flow up to 40 gpm. 1¼" flow up to 45 gpm.

Code	Description	Lbs	USD
519502A	¾" NPT male union	1.0	<b>134.00</b>
519566A	¾" press union	1.0	<b>152.00</b>
519599A	¾" sweat union	1.0	<b>133.00</b>
519600A	1" FNPT in, 1" NPT male union out	1.4	<b>210.00</b>
519609A	1" FNPT in, 1" sweat union out	1.4	<b>210.00</b>
519700A	1¼" FNPT in, 1¼" NPT male union out	1.5	<b>252.00</b>
519709A	1¼" FNPT in, 1¼" sweat union out	1.5	<b>252.00</b>

**UNIVERSAL FLOW SWITCH**



**626 Uni-Switch™**

Universal flow switch. Suitable for 1" to 8" pipe size. Working pressure: 150 psi. Working temperature range: -20° – 250°F. Minimum flow: 5.7 gpm. Switch contacts: NO or NC. Switch rating: 15 A. CE, cUL, NEMA Type 3, IP 54.



Code	Description	Lbs	USD
626600A	1" NPT male thread	2.3	<b>263.00</b>
626009	Replacement paddle assembly*	0.1	<b>24.60</b>

\* stainless steel

**MISCELLANEOUS COMPONENTS**



**NA101**

Ball valve. Brass body. Max. working pressure: 600 psi. Max. working temperature: 365°F.

Code	Description	Lbs	USD
NA10167	½" sweat x ½" sweat	0.5	<b>10.30</b>



**NA510**

NBR, POM check valve. Max. percentage of glycol: 50%. Max. working pressure: 150 psi. Temperature range: 32° – 150°F (190°F for max. 1 hour). Opening pressure differential: 0.25 psi (½" through 1¼"); 0.50 psi (1½", 2").

Code	Description	Cv	Lbs	USD
NA51069	1" sweat union	17	1.0	<b>76.50</b>



**538**

Drain valve. Brass body. ¾" garden hose thread with cap. Max. working pressure: 150 psi. Max. working temperature: 250°F.

Code	Description	Lbs	USD
538202 FD	¼" NPT male x ¾" GHT	0.3	<b>15.20</b>
538402 FD	½" NPT male x ¾" GHT	0.3	<b>15.60</b>



**NA503**

Tridicator dual pressure / temperature gauge for boilers. Dial size: 3 1/8". Pressure range: 0–75 psi. Temperature range: 60°–320°F. ¼" NPT rear probe. For direct fluid stream submersion.

Code	Description	Lbs	USD
NA503040	¼" NPT male center back	0.2	<b>38.10</b>

# PODCAST SERIES EXCELLENCE IN EDUCATION



**ASK**   
**CALEFFI**



The **Ask Caleffi** podcast Series features our tech support wizards behind the mic. Listen in as Greg Tubbs and Dan Firkus discuss **tricky heating and plumbing system problems**. Learn how this dynamic duo solves in-the-field perplexities while intermingling helpful technical tips and entertaining experiences. **CALEFFI GUARANTEED.**

# RENEWABLES, SOLAR AND BIOMASS DEVICES

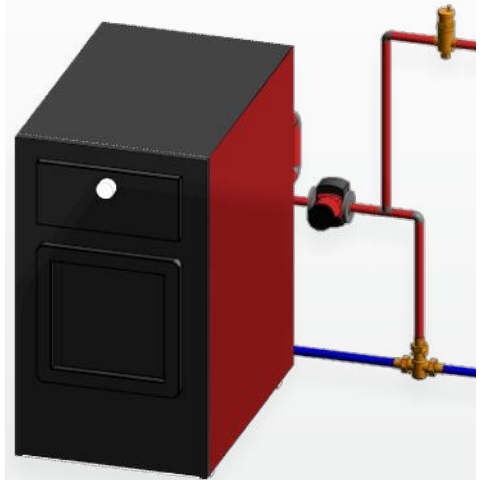
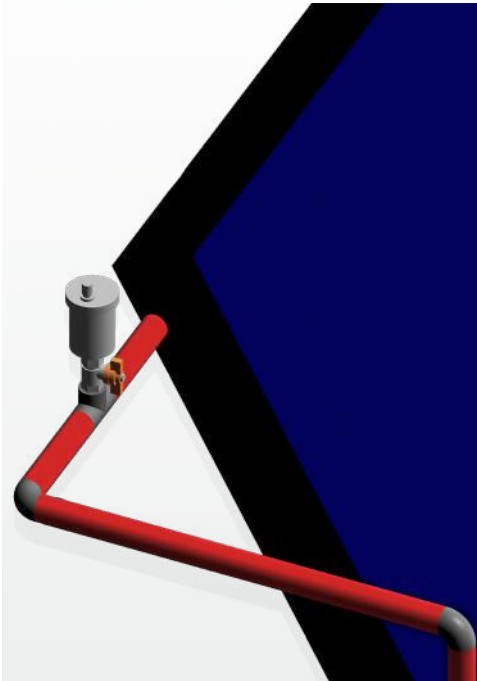
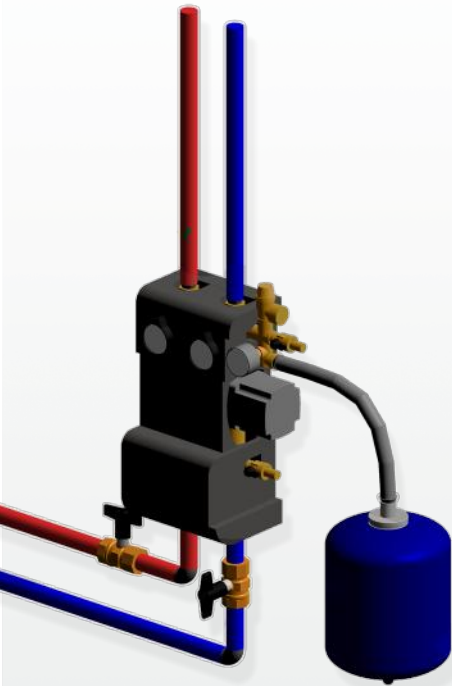

This diagram is for illustration purposes only



[bim.caleffi.com](http://bim.caleffi.com)

## PRODUCTS INCLUDED IN SECTION

- Pump stations and fittings
- Solar mixing valves
- Air vents, air separator, and safety relief valves
- Boiler protection valve accessories
- Boiler protection high-flow thermostatic mixing valves

**SOLAR PUMP STATIONS**

**278 & 279**



Solar pump stations are pre-assembled and leak-tested. Safety relief valve. Ball valves with built-in flow checks in return (and flow for dual-line models). Temperature gauges in return (and flow for dual-line models). Pressure gauge. Manual air vent (dual-line models only). Expansion tank connection. Connections for flushing and filling. Foam insulation. Balance/flow meter: 1 – 8 gpm scale. Pump: three speed. Pump performance: 19 ft head/8 gpm. Safety relief valve: 90 psi. Max. working pressure: 145 psi. Max. working temp: 350°F. Connections: ¾" female thread.

(Select adaptors to the right)



Code	Description	Lbs	USD
<b>279051A</b>	Dual-line solar pump station	17	<b>1,058.00</b>
<b>279051</b>	Dual-line solar station w/o pump	12	<b>846.00</b>
<b>278751A</b>	Single-line solar pump station	14	<b>923.00</b>
<b>278751</b>	Single-line solar station w/o pump	10	<b>711.00</b>
<b>278011</b>	Controller housing	0.5	<b>51.50</b>

**DRAINBACK PUMP STATION**

**278**



Drainback solar pump station designed with a high head and steep pump curve which are pre-assembled and leak-tested. Safety relief valve, ball valve, temperature gauge, pressure gauge, air fill valve. Connections for flushing and filling with foam insulation. Balance/flow meter: 2—8 gpm scale. Pump: Grundfos UP15-100. Performance: 36 feet head / 8 gpm. Safety relief valve: 90 psi. Max. working pressure: 145 psi. Max. working temp: 350°F. Connections: ¾" female thread. (Select adaptors to the left)

Code	Description	Lbs	USD
<b>278951A</b>	Drainback solar pump station	14	<b>985.00</b>



Replacement pump fits current solar pump stations 278 & 279, plus discontinued 255 & 256 stations. 3 speed 115 V. 1" male union thread. Agency approval: cULus. (install in-line with NA122 union fittings on page 84)

Code	Description	Lbs	USD
<b>NA10481</b>	Grundfos 15-58U, 21' head / 18 gpm	5.0	<b>273.00</b>

**HIGH TEMPERATURE PREMIX GLYCOL**



**NA101 SolarHD™**

Pre-mixed 50% high temperature non toxic glycol, FDA reference: 21 CRF 182.1666, Gosselin TOXICITY INDEX 1, Generally recognized as safe for use as direct food additives. NSF listed, Category Code: HT1, HT2, NSF Registration No. 144912. Compatible with other propylene glycols.

Code	Description	Lbs	USD
<b>NA10103</b>	5 gallon bucket	45	<b>324.00</b>





**PUMP STATION FITTINGS**



3/4" sweat fittings to top or bottom.  
2 each.

Code	Description	Lbs	USD
<b>NA26659</b>	3/4" male thread x 3/4" sweat fitting	0.6	<b>87.00</b>



3/4" sweat fittings to top and bottom. 4 each.

Code	Description	Lbs	USD
<b>NA26759</b>	3/4" male thread x 3/4" sweat fitting	1.0	<b>174.00</b>



1" sweat fittings to top or bottom.  
2 each.

Code	Description	Lbs	USD
<b>NA26669</b>	3/4" male thread x 1" sweat fitting	0.6	<b>95.40</b>



1" sweat fittings to top and bottom. 4 each.

Code	Description	Lbs	USD
<b>NA26769</b>	3/4" male thread x 1" sweat fitting	1.0	<b>191.00</b>

**BOILER PROTECTION ACCESSORIES**



**F296**

Replacement thermostatic sensor cartridges. Sensor cartridge accuracy: ±4°F. By-pass from boiler complete closing temperature: Tset +18°F (130°+18°=148°F).

Fits 280 and 281 Series boiler protection valves. Easy replacement to change the 280 valve set temperature without removing the valve body from the piping.

Code	Description	Lbs	USD
<b>F29633</b>	115°F Tset	0.2	<b>32.20</b>
<b>F29634</b>	130°F Tset	0.2	<b>32.20</b>
<b>F29635</b>	140°F Tset	0.2	<b>32.20</b>
<b>F29636</b>	160°F Tset	0.2	<b>32.20</b>

Selection note: thermostatic sensor cartridge will completely close at Tset value +18°F. Example: (130°F Tset +18°F=148°F completely closed) ±4°F.

**BOILER PROTECTION HIGH-FLOW THERMOSTATIC MIXING VALVES**

**280 ThermoProtect™**



Boiler protection high-flow thermostatic mixing valve. Changeable thermostatic sensor cartridge. Brass body and lower plug. Max. working pressure: 150 psi. Working temperature range: 40°—212°F. Thermostatic sensor cartridge: 130°F & 140°F Tset standard selections, see below. 115°F, 160°F Tset optional (field replaceable). Sensor cartridge accuracy: ±4°F. By-pass from boiler complete closing temperature: Tset +18°F (ex. 130°+18°=148°F).

Code	Description	Lbs	USD
<b>280965A</b>	1" sweat unions 130°F Tset	11	<b>319.00</b>
<b>280165A</b>	1" NPT female unions 130°F Tset	11	<b>341.00</b>
<b>280966A</b>	1" sweat unions 140°F Tset	11	<b>319.00</b>
<b>280166A</b>	1" NPT female unions 140°F Tset	11	<b>341.00</b>
<b>280975A</b>	1 1/4" sweat unions 130°F Tset	11	<b>375.00</b>
<b>280175A</b>	1 1/4" NPT female unions 130°F Tset	11	<b>391.00</b>
<b>280976A</b>	1 1/4" sweat unions 140°F Tset	11	<b>375.00</b>
<b>280176A</b>	1 1/4" NPT female unions 140°F Tset	11	<b>391.00</b>

**BOILER PROTECTION RECIRCULATION AND DISTRIBUTION UNITS**

**281 ThermoBloc™**



ThermoBloc replacement pump only, for existing installations.

Code	Description	Lbs	USD
<b>F19379</b>	Replacement Pump	5.0	<b>416.00</b>



**F295**

Dual scale temperature gauge 280 and 281 Series boiler protection valves.

Code	Description	Lbs	USD
<b>F29571</b>	32—250°F	0.2	<b>27.30</b>

**SOLAR LOW LEAD MIXING VALVES**



**2521**

Adjustable thermostatic three-way mixing valve for solar systems with built-in inlet check valves.  
 Setting range: 80°—150°F.  
 Max. working pressure: 200 psi.  
 Max. inlet temperature: 210°F.  
 Connection: ½", ¾", 1" sweat.  
 Certified to ASSE 1017, CSA B125.3, UPC, IPC, Low Lead Laws and listed by ICC-ES for use in accordance with the U.S. and Canadian plumbing codes.

**Operating principle**

The controlling element of the solar thermostatic mixing valve is a temperature sensor that is fully immersed in the mixed water outlet passage. As it expands or contracts, the sensor continuously establishes the correct proportion of hot and cold water entering the valve. The flow is regulated by a piston sliding in a cylinder between the hot and cold water passages. Even when there are pressure drops due to the drawing off of hot or cold water for other uses or variations in the incoming temperature, the mixer automatically regulates the water flow to obtain the required temperature.

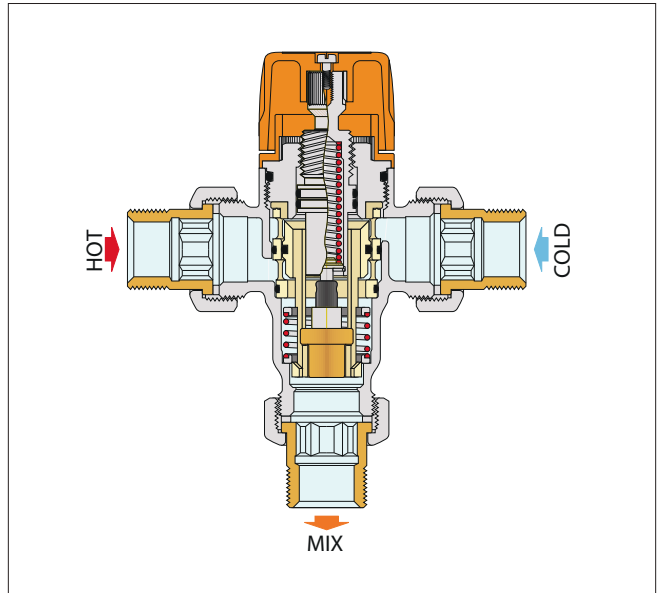

Code	Description	Lbs	USD
<b>252149A</b>	½" sweat unions	1.2	<b>203.00</b>
<b>252158A</b>	¾" sweat unions with gauge	1.2	<b>264.00</b>
<b>252159A</b>	¾" sweat unions	1.2	<b>214.00</b>
<b>252168A</b>	1" sweat unions with gauge	1.2	<b>300.00</b>
<b>252169A</b>	1" sweat unions	1.2	<b>249.00</b>



Check valve for use in 2521 mixing valve.  
 Max. inlet temperature: 210°F.

Code	Description	Lbs	USD
<b>R29326</b>	Check valve insert	0.1	<b>7.60</b>

**AIR SEPARATOR AND SAFETY RELIEF VALVES**



**251 DISCAL®**

Air separator for solar heating systems.  
 Working temperature range: -20°—320°F.  
 Max. working pressure: 150 psi.  
 Max. discharge pressure: 150 psi.  
 Connections: Main, ¾" NPT, female.  
 Bottom, ½" NPT, female.



**253**

Safety relief valves for solar systems.  
 Working temperature range: -20°—360°F.  
 Normal pressure: 150 psi.  
 Opening over pressure: 10%.  
 Closing differential: 20%.  
 Discharge capacity: 171,000 Btu.  
 Connections: Inlet, ½" female.  
 Discharge, ¾" female.  
 TÜV certified to TRD-721-SV100 7.7.  
 Meets ANSI Z21.22 standard.

TÜV Rheinland is an approved U.S. Nationally Recognized Testing Laboratory (NRTL) Certification Body for Pressure Equipment. Meets ANSI Z21.22 "Relief Valves for Hot Water Supply Systems."



Code	Description	Lbs	USD
<b>251003A</b>	¾" FNPT	2.0	<b>188.00</b>

Code	Description	Lbs	USD
<b>253042</b>	Factory set to 35 psi	0.3	<b>63.00</b>
<b>253043</b>	Factory set to 45 psi	0.3	<b>63.00</b>
<b>253044</b>	Factory set to 60 psi	0.3	<b>63.00</b>
<b>253046</b>	Factory set to 90 psi	0.3	<b>63.00</b>
<b>253048</b>	Factory set to 120 psi	0.3	<b>63.00</b>
<b>253040</b>	Factory set to 150 psi	0.3	<b>63.00</b>

**AUTOMATIC AIR VENTS**

**250**



Automatic air vent for solar systems.  
Working temperature range: -20°—360°F.  
Max. working pressure: 150 psi.  
Max. discharge pressure: 75 psi.

Code	Description	Lbs	USD
<b>250041A</b>	½" MNPT	0.3	<b>66.50</b>

**Function**

Automatic air vents are used in the closed circuits of solar heating systems. They allow air contained in the fluid to be released automatically during the filling process, through a valve operated by a float in contact with fluid in the system.

The shut-off valves are used in combination with the automatic air vents to isolate them after filling the circuit of solar heating systems. This product has been specially made to work at high temperatures with a glycol medium.

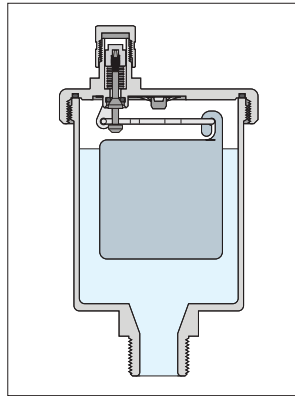

**NA292**



Shut-off fits automatic air vent.  
Working temperature range: -20°—360°F.  
Max. working pressure: 150 psi.

Code	Description	Lbs	USD
<b>NA29284</b>	½" FNPT x ½" MNPT	0.2	<b>51.60</b>

**251**

**DISCALAIR®**



High-performance automatic air vent for solar heating systems.  
Working temperature range: -20°—320°F.  
Max. working pressure: 150 psi.  
Max. discharge pressure: 150 psi.

Code	Description	Lbs	USD
<b>251004A</b>	½" FNPT and ¾" MNPT	0.8	<b>142.00</b>

**Function**

DISCALAIR® solar devices are used in hydronic systems or in the filling and start-up phase of solar heating systems to discharge evenly discharge large quantities of air that have formed in the circuits. This function is performed even when there is considerable pressure due to the special geometry of the discharge mechanism, which is identical to the mechanism on DISCAL® Solar 251 Series air separators.

This product has been specifically designed to work at high temperature with a glycol medium, which is typical of solar heating systems.

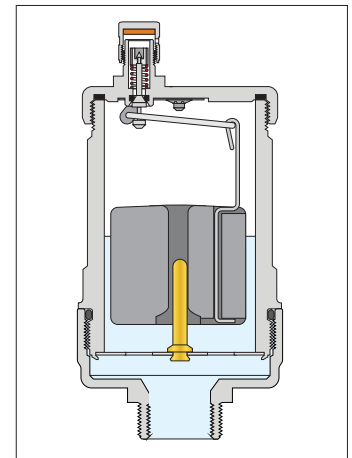

**NA102**



Vent cap adapter to connect discharge tube. Fits all air vents and air separators except 5026 and 5027 Series.

Code	Description	Lbs	USD
<b>NA10204</b>	¼" MNPT	0.1	<b>22.00</b>

# CONTECA™

## MEASURE RECORD THERMAL ENERGY



**CONTECA™** is a direct heat meter that precisely measures and records instantaneous and totalized thermal energy usage in residential and commercial buildings. Data transmission includes RS-485 with selectable Modbus or M-Bus protocol. CONTECA is easy to install and commission. **The heat meter complies with ASTM E3137/ E3137M and is approved by Measurement Canada. CALEFFI GUARANTEED.**



# ENERGY METERS

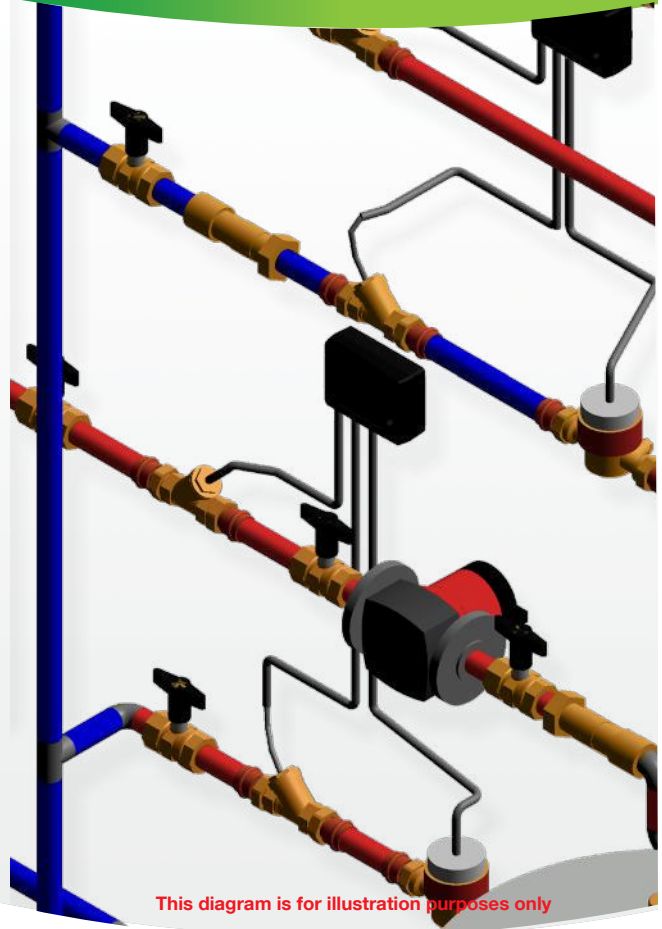
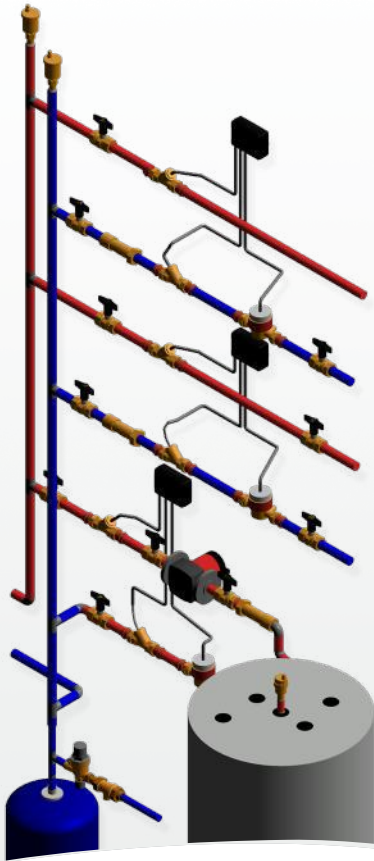

  
bim.caleffi.com

## PRODUCTS INCLUDED IN SECTION

- Energy meters
- Energy meter accessories

ENERGY METERS



Code	Description	Lbs	USD
750449A	Energy Meter, 0.25 to 10 GPM, ½" sweat	6.2	1,043.00
750440A	Energy Meter, 0.25 to 10 GPM, ½" MNPT	6.2	1,084.00
750446A	Energy Meter, 0.25 to 10 GPM, ½" press	6.2	1,137.00
750459A	Energy Meter, 0.25 to 10 GPM, ¾" sweat	7.1	1,056.00
750450A	Energy Meter, 0.25 to 10 GPM, ¾" MNPT	7.1	1,097.00
750456A	Energy Meter, 0.25 to 10 GPM, ¾" press	7.1	1,149.00
750469A	Energy Meter, 0.25 to 10 GPM, 1" sweat	7.9	1,109.00
750460A	Energy Meter, 0.25 to 10 GPM, 1" MNPT	7.9	1,149.00
750466A	Energy Meter, 0.25 to 10 GPM, 1" press	7.9	1,203.00
750463A	Energy Meter, 0.3 to 15 GPM, 1" FNPT	12	1,547.00
750473A	Energy Meter, 0.5 to 25 GPM, 1¼" FNPT	13	1,652.00
750483A	Energy Meter, 1 to 45 GPM, 1½" FNPT	19	1,916.00
750410A	Energy Meter, 11 - 110 GPM, 2½" flanges	27	2,916.00
750411A	Energy Meter, 14 - 140 GPM, 3" flanges	29	3,679.00
750412A	Energy Meter, 22 - 220 GPM, 4" flanges	44	4,830.00
750413A	Energy Meter, 35 - 350 GPM, 5" flanges	51	5,514.00
750414A	Energy Meter, 88 - 880 GPM, 6" flanges	88	6,562.00
750415A	Energy Meter, 100 - 1000 GPM, 8" flanges	110	7,351.00

Standard installation

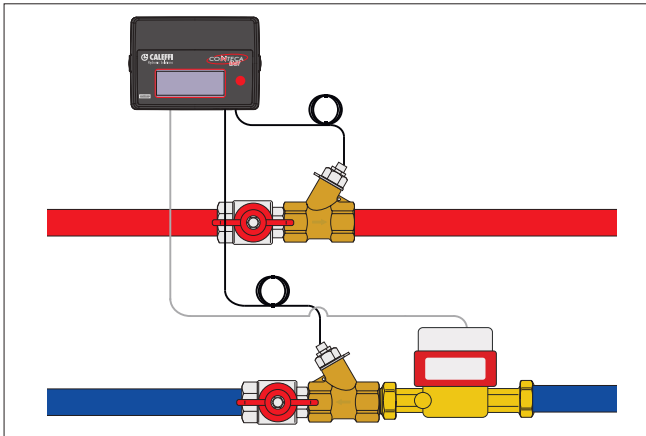

7504  
CONTECA™ Energy meter

CONTECA™ is a direct heat meter designed to measure instantaneous and recorded history of thermal energy usage in residential and commercial buildings.

Micro processor:

Power supply: 24 VAC, 50/60 Hz, 1W.

Data transmission: 2-wire RS-485; selectable Modbus or M-bus (for use with Datalogger).

Ambient temperature: 40° – 113°F (4° – 45°C).

Environmental rating: NEMA 3S (IP 54).

Pulse inputs: Class 1B per EN 1434-2.

Temperature sensors:

Cable length: 26¼ feet (8 m).

Sensor type: 100 kohm NTC matched.

Temperature sensitivity: < 0.1°F.

Flow meters:

Body material: Brass.

Body threads: ISO 228 male straight.

Piping connections: Dual unions, tailpieces NPT, sweat, flanged, press.

Max. working pressure: 150 psi (10 bar)



Function

The CONTECA meter features an 8-digit liquid crystal display that enables easy reading of BTU consumed as well as a range of technical data indicating equipment operating status and data logging.

Each CONTECA includes an electronic calculator/user interface, two temperature sensors, fittings included. The flow meter comes with the CONTECA meter kit. In addition to the two temperature inputs and flow meter input, four additional pulse inputs, for optional equipment monitoring and data logging. The CONTECA is easy to install and commission, and complies with ASTM E3137 specification for heat metering instrumentation and European directive 2014/32/UE EN 1434 (MI 004). Approved by Measurement Canada for use in heat metering applications in Canada.

The meter has integral RS-485 Modbus protocol 2-wire communication (default) for remote access and configuration when BAS is MODBUS-RT. The RS-485 protocol must be changed to M-bus when using the Datalogger. Up to 250 CONTECA meters can connect to one CONTECA data logger.

Lead seals (included with each kit) to prevent tampering

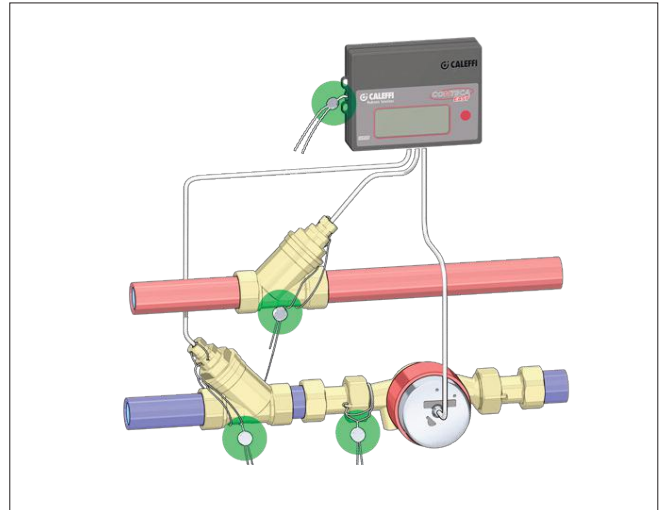

ENERGY METERS

**7504**  
**CONTECA™ Datalogger**



Power supply: 24 V (DC) ±10%, 24 V (AC) - 3 W.  
2 Ethernet ports: ETH1 (PoE), ETH2.  
Ambient temperature range: 32°—122°F.  
Mounting: on a 35 mm DIN rail (EN 60715).  
Network addresses: up to 250 Conteca heat meters.  
Daily data logging: 10 years.  
Reports: In XLS or CSV format.



Code	Description	Lbs	USD
<b>750450</b>	Conteca Datalogger	2.0	<b>2,436.00</b>



MODBUS-RT-to-BACnet gateway.  
Converts CONTECA™ controller MODBUS-RT (RS-485 serial) output communication to BACnet IP or MSTP communication.  
Network capacity: up to 1500 registers (approx. 50 CONTECA heat meters).

Code	Description	Lbs	USD
<b>755052</b>	MODBUS-RT-to-BACnet gateway	1.0	<b>2,007.00</b>



Wall transformer.  
Input voltage: 120 V AC.  
Output voltage: 24 V AC.  
Power output: 20 VA.  
Agency approval: cULus.

Code	Description	Lbs	USD
<b>NA10759</b>	24 V AC wall transformer, 20 VA	1.0	<b>40.60</b>

**V40 Replacement**



Replacement flow meter (body only)  
Single jet rotary pulse flow meter measures liquid flow for energy heat metering production or consumption. Accurate to International Standards OIML R75, EN1434 and MID.  
Brass body.  
Sweat connections included.  
Working temperature range: -40°—210°F.  
Max. fluid temperature: 265°F  
Max. working pressure: 235 psi.  
Maximum glycol: 50%.

Code	Description	Lbs	USD
<b>R79701</b>	0.25 to 10 GPM	3.0	<b>478.00</b>

**V40 Replacement**



Replacement flow meter (body only)  
Multi-jet rotary pulse flow meter measures liquid flow for energy heat metering production or consumption. Accurate to International Standards OIML R75, EN1434 and MID.  
Brass body.  
Sweat connections included.  
Working temperature range: -40°—210°F.  
Max. fluid temperature: 265°F.  
Max. working pressure: 235 psi.  
Maximum glycol: 50%.

Code	Description	Lbs	USD
<b>R79702</b>	0.3 to 15 GPM	5.0	<b>852.00</b>
<b>R79703</b>	0.5 to 25 GPM	8.0	<b>1,008.00</b>
<b>R79704</b>	1 to 45 GPM	14	<b>1,197.00</b>

Application Diagram

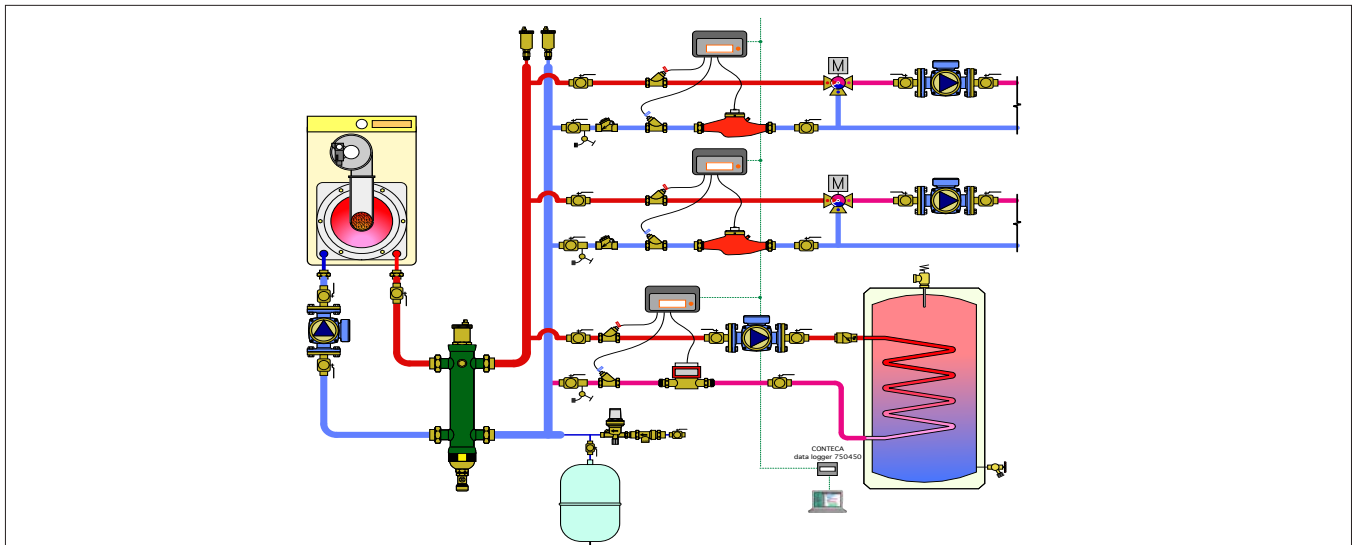

# CALEFFI BIM LIBRARY THE HEART OF YOUR DESIGNS



## BIM



Caleffi is BIM ready and we are eager to share our design know-how. The whole library is natively modeled in REVIT so files are of the highest quality, delivered in a user-friendly file size. Each family contains the parametric variants to allow calculation functions within AUTODESK® REVIT®. Choose Caleffi as part of your standard of excellence in design. **CALEFFI GUARANTEED.**

**Download the free library**

[bim.caleffi.com](http://bim.caleffi.com)

**For more information**

[woody.dickinson@caleffi.com](mailto:woody.dickinson@caleffi.com)





# LIMITED WARRANTY

**COVERAGE:** Caleffi North America Inc. ("WARRANTOR") warrants that each Caleffi PRODUCT will be free from defects in material and workmanship for a period of two years\* from the date of shipment/delivery of the PRODUCT (that can be identified by the "Caleffi" trademark, trade name, or logo affixed to them). The Limited Warranty is referred to herein as "the Limited warranty." The PURCHASER's sole and exclusive remedy under this Limited Warranty for defects in the PRODUCT shall be the repair, replacement or refund of the purchase price, in WARRANTOR's sole discretion, of the defective PRODUCT, or components thereof.

**\*PRODUCT warranty exceptions:**

Switching Zone Relays	3 years
Switching zone relays + valves (Z-one valves and Z-one relays installed together)	5 years

**NOT COVERED:** This Limited Warranty also does not apply to, and WARRANTOR shall have no liability or responsibility in respect of, damages or expenses relating to:

- The failure to properly store, transport, install or use the PRODUCT as, for example, specified in any manuals or other literature supplied by WARRANTOR, on WARRANTOR's website, or in accordance with any applicable laws, codes, regulators or standards;
- Any PRODUCT purchased from any entity other than WARRANTOR;
- Alteration, change or modification of the PRODUCT, including its subcomponents, parts or assemblies;
- WARRANTOR also makes no warranty that a PRODUCT manufactured does not infringe the intellectual property or other proprietary rights of any third party;
- Accidents, misuse, abuse, abnormal use, improper use, negligent use, wilful misconduct, or use exceeding the recommended and permitted limits of the PRODUCT, and/or normal wear or deterioration;
- Any defect or non-conformity that has not been timely and promptly communicated in writing to WARRANTOR as set forth herein.
- Any damage, cost or expense caused by Act of God; or
- Loss of time, loss of use, inconvenience, loss of profits, lost business, lost business opportunities, damage to reputation, goodwill and any incidental or consequential damages arising out of or relating to the PRODUCT, or other matters not specifically covered hereunder.

**PROCEDURE:** Upon delivery, PURCHASER shall, within one (3) business day, inspect the PRODUCT for conformity and visible defects. PURCHASER shall give WARRANTOR immediate written, specific and detailed notice of any non-conformities or defects regarding the PRODUCT. Upon receipt of the written notice of claim, WARRANTOR shall have the right to inspect the PRODUCT. In the event of a defect covered by this Limited Warranty, WARRANTOR will, at WARRANTOR's discretion, repair or replace the PRODUCT or any component of the PRODUCT or refund the purchase price for that particular PRODUCT. In the event that PURCHASER submits a warranty claim that, in the sole reasonable discretion of the WARRANTOR, is unfounded, the PURCHASER shall reimburse the WARRANTOR all reasonable costs incurred by the WARRANTOR in evaluating the warranty claim (i.e. travel, lodging, expert evaluations, etc.). WARRANTOR must approve, in advance and in writing, all repairs or replacements covered under or performed pursuant to this Limited Warranty. Any warranty repairs or service must be performed exclusively by WARRANTOR or other authorized representative of WARRANTOR or by another servicing facility pre-approved in writing by WARRANTOR. Acceptance of any Limited Warranty claim is not an admission that any PRODUCT or any of its component parts are defective. The PURCHASER forfeits any rights it may have under this Limited Warranty if the PURCHASER does not follow the procedure described herein.

All requests and notices under this Limited Warranty shall be directed to:

**Caleffi North America Inc.**  
3883 West Milwaukee Road  
Milwaukee, WI 53208  
E-Mail: returns.us@caleffi.com  
Phone (414) 238-2360  
Fax: (414) 238-2366

**LIMITATION OF DAMAGES:** Except as expressly provided by this Limited Warranty, **WARRANTOR SHALL NOT BE RESPONSIBLE FOR ANY INCIDENTAL OR CONSEQUENTIAL DAMAGES ASSOCIATED WITH THE USE OR NON-USE OF THE PRODUCT OR A CLAIM UNDER THIS LIMITED WARRANTY, WHETHER THE CLAIM IS BASED ON CONTRACT, TORT OR OTHERWISE.** The foregoing statements of warranty are exclusive and in lieu of all other remedies or damages. Some states do not allow the exclusion or limitation of incidental or consequential damages, so only in this case this limitation or exclusion may not apply to you. This Limited Warranty shall be the sole and exclusive remedy available to the PURCHASER with respect to this PRODUCT. In the event of any alleged breach of any warranty or any legal action brought by the PURCHASER, based on breach of warranty, alleged negligence or other tortious conduct by WARRANTOR, the PURCHASER's sole and exclusive remedy will be the repair or replacement of any defective PRODUCT as stated herein. In no event shall the liability of the WARRANTOR exceed the purchase price of the PRODUCT.

**DISCLAIMER: ANY IMPLIED WARRANTY OF MERCHANTABILITY OR FITNESS FOR A PARTICULAR PURPOSE AND ALL IMPLIED WARRANTIES ARISING FROM A COURSE OF DEALING, USAGE OF TRADE, BY STATUTE OR OTHERWISE, IS HEREBY STRICTLY LIMITED TO THE TERM OF THIS WRITTEN WARRANTY.** This Limited Warranty shall be the sole and exclusive remedy available to the PURCHASER with respect to this PRODUCT. In the event of any alleged breach of any warranty or any legal action brought by the PURCHASER based on alleged negligence or other tortious conduct by WARRANTOR, the PURCHASER'S sole and exclusive remedy will be repair or replacement of defective materials or refund of the purchase price, as stated herein.

**TRANSFER OF LIMITED WARRANTY:** This warranty is made by WARRANTOR with only first PURCHASER of the PRODUCT and does not extend to any subsequent PURCHASER or any third parties. The unexpired portion of this Limited Warranty may not be transferred to any entity.

**APPLICABLE LAW:** The parties expressly acknowledge and irrevocably agree that any and all claims or disputes arising out of or otherwise relating to this Limited Warranty shall be decided by a binding arbitration administered by the American Arbitration Association pursuant to Commercial Industry Rules in effect as of the date of this Limited Warranty, to the exclusion of any courts of any place, except as necessary for the enforcement of arbitration rights. The place for any such arbitration shall be The State of Wisconsin. PURCHASER expressly waives any provision of law in the jurisdiction in which PURCHASER is located or any other potentially applicable law which conflicts with any provision of this Limited Warranty at any time.

**OTHER RIGHTS: Your acceptance of delivery of The PRODUCT constitutes your acceptance of the terms of this Limited Warranty.** This Limited Warranty gives you specific legal rights, and you may also have other rights which vary from state to state. If any term or provision of this Limited Warranty is invalid or unenforceable under any local, state, or federal law, statute, judicial decision, regulation, ordinance, executive order or other rule of law, such term shall be deemed reformed or deleted, but only to the extent necessary to comply with such statute, regulation, ordinance, order or rule and the remaining provisions of this Limited Warranty shall remain in full force and effect.

**ENTIRE AGREEMENT:** This document alone contains the entire Limited Warranty given by WARRANTOR in respect of the PRODUCT. Nothing in WARRANTOR's product literature, marketing materials, advertisements and technical specifications expand or enlarge the scope of this Limited Warranty. There are no terms, promises, conditions or warranties regarding the PRODUCT other than those expressly contained herein. WARRANTOR specifically does not authorize any person, including but not limited to any dealer or other agent or employee of WARRANTOR, to extend the time, scope, terms or conditions of this Limited Warranty or to create or assume for WARRANTOR any other obligation or liability with respect to the PRODUCT or other products designed, manufactured or sold by WARRANTOR. All terms of this Limited Warranty are contractual and not mere recitals, and constitute material terms of this Limited Warranty. It is agreed and acknowledged that the provisions of this Limited Warranty allocate the risks between WARRANTOR and PURCHASER, that WARRANTOR's pricing reflects this allocation of risk, and but for this allocation and limitation of liability, WARRANTOR would not have entered into this Limited Warranty. The agents, employees, and dealers of Caleffi Products are not authorized to make modifications to this limited warranty or make additional warranties binding on Caleffi.

**THIS DOCUMENT AND ALL PROVISIONS CONTAINED HAS BEEN SPECIFICALLY AGREED BETWEEN THE PARTIES.**



## HAVE A QUESTION? WANT TO LEARN MORE?

We are committed to your success and are here to help. Check out our website [CALEFFI.US](http://CALEFFI.US) to explore an expansive collection of product information, training webinars, BIM objects, and our expansive library of educational idronics™ journals.

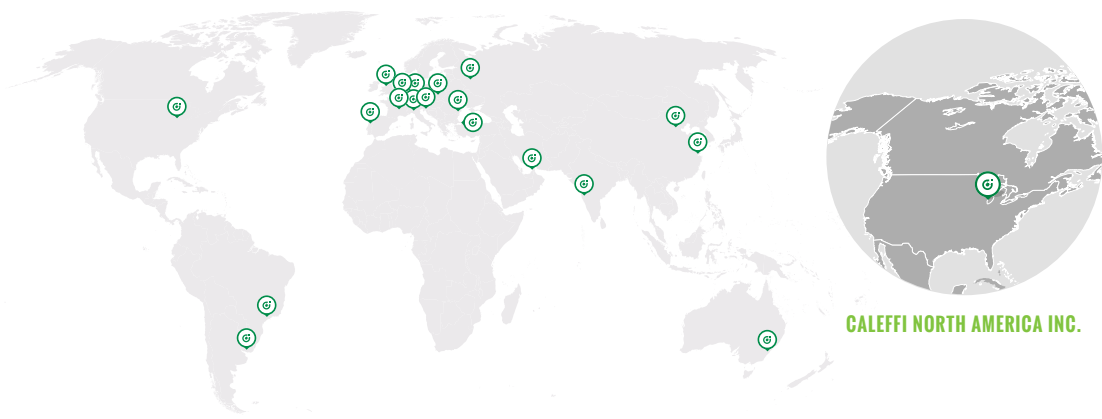

CALEFFI NORTH AMERICA INC.

## INQUIRIES:

**SALES:**  
[sales@caleffi.com](mailto:sales@caleffi.com)

**TECHNICAL SUPPORT:**  
[techsupport.us@caleffi.com](mailto:techsupport.us@caleffi.com)

**MARKETING/PR:**  
[marketing.us@caleffi.com](mailto:marketing.us@caleffi.com)

**FIND YOUR NEAREST  
REPRESENTATIVE**  
[www.caleffi.info/dealerlocator/](http://www.caleffi.info/dealerlocator/)



Suggested List Price  
Effective February 1, 2023  
Canceling All Prior Issues

Specifications and prices are subject to change without notice

**Caleffi North America, Inc.**

3883 West Milwaukee Road · Milwaukee, WI 53208

Tel: 414.238.2360 · Fax: 414.238.2366

[sales@caleffi.com](mailto:sales@caleffi.com) | [www.caleffi.com](http://www.caleffi.com)

© 2023 Copyright Caleffi

SKU: 23-001